

V-Series

Contura Rotary Switch

The V-Series Contura Rotary Switch was designed for maximum performance and reliability leveraging the features of the widely popular V-series Contura Rocker Switches.

Available in maintained and momentary circuit options, the V-Series Rotary features a sturdy knob construction, up to three separate LEDs, and fits in an industry standard panel opening.

Internally, the V-Series Contura Rotary uses a patented mechanism that translates rotary to linear motion. This allows for common switch functionality and terminal connections with the V-Series rocker version and requires no harness change. A secondary CAM, which helps drive the mechanism, provides definitive detent positions and prevents the switch from stopping between positions, while improving tactile feel.

The V-Series Rotary also features an innovative PC board that supports the LED and surface mount resistors; and IP67 sealing protection above panel by utilizing LED and actuator stem seals. Together, these features make the V-Series Contura Rotary switch the best choice available in the market today.

Typical Applications:

- ◆ On/Off Highway Equipment
- ◆ Marine
- ◆ Test & Measurement
- ◆ Instrumentation
- ◆ Speed Control



Product Highlights:

- ◆ Accommodates up to three separate LEDs
- ◆ Patented mechanism translates rotary into linear motion
- ◆ Secondary CAM for definitive detent positions
- ◆ PC Board supports LED and surface mount resistors
- ◆ IP67 sealing protection above panel
- ◆ Common terminal & circuit functionality with V-Series Rocker switches, with no harness change required



Carling Technologies™
Innovative Designs. Powerful Solutions.

Carling Technologies, Inc.
60 Johnson Avenue • Plainville, CT 06062
Phone: (860) 793-9281 • Fax: (860) 793-9231
Email: sales@carlingtech.com • www.carlingtech.com

V-Series Rotary Switch

DESIGN FEATURES

OPTIONAL PANEL SEAL

Prevents water/dust ingress behind panel

SEALS

LED and stem seals provide IP67 protection above panel

PC BOARD

Supports LEDs and surface mount resistors

TERMINALS

Same pinout as V-Series Rocker Switches, requiring no harness change

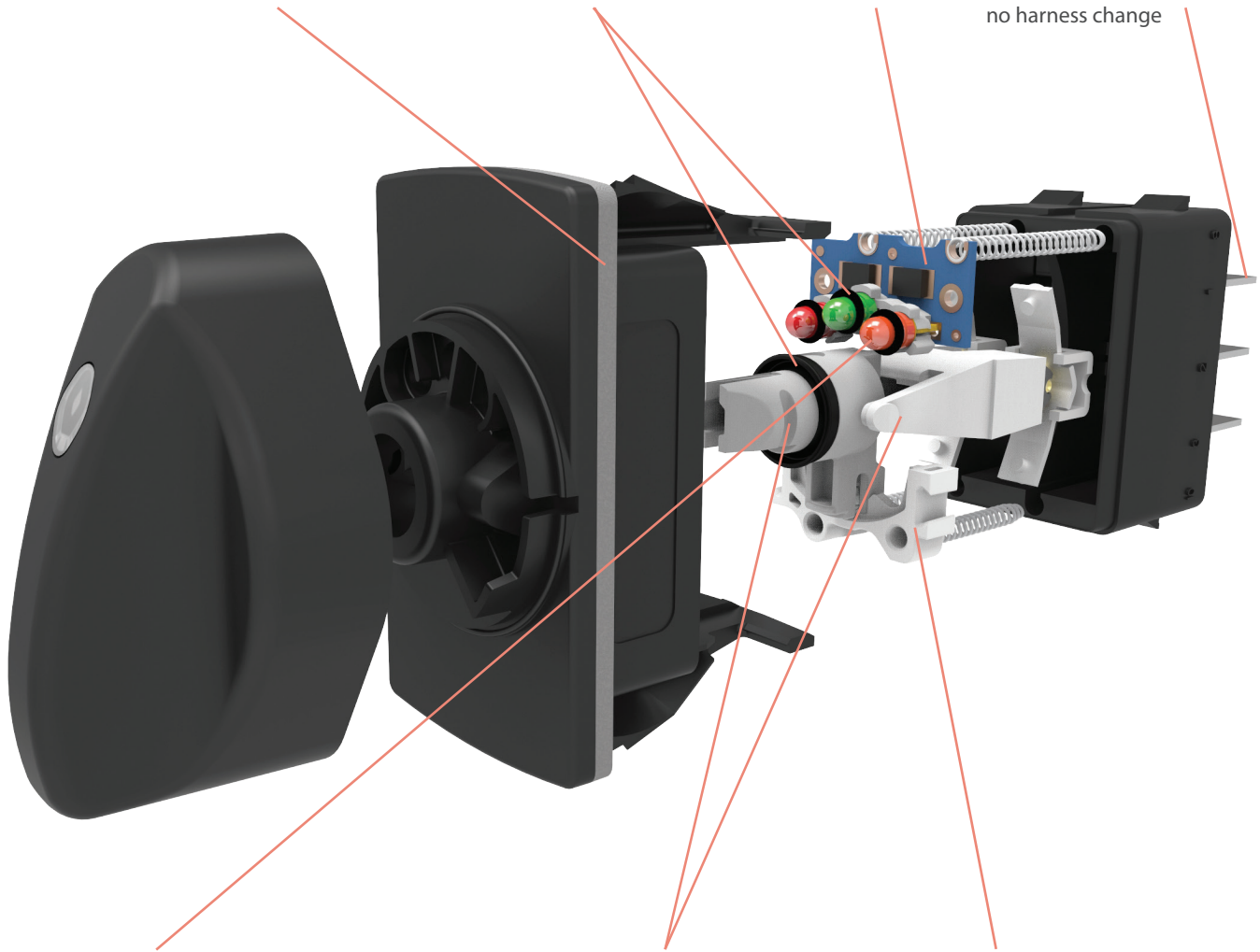

LEDS

Up to three separate LEDs

ROTARY & LINEAR ACTUATOR

Patented mechanism that translates rotary to linear motion

SECONDARY CAM

Provides definitive detent positions with ball & spring located in rotary actuator

Electrical

Rating

Circuit	Voltage	Max Current Resistive
2 Position Maintain	12	20
2 Position Momentary	12	20
3 Position All	12	20
2 Position Maintain	24	15
2 Position Momentary	24	15
3 Position All	24	15

Dielectric Strength	1500 Volts RMS
Insulation Resistance	50 Megohms
Initial Contact Resistance	10 Milli Ohm max @ 4VDC
Life	50,000 Cycles Two Position 25,000 Cycles Two Position Momentary and All Three position
Terminals	0.250" (6.3mm) Quick Connect

Physical

Function Circuits	Single and Double Pole Single Throw, SPST, DPST Single and Double Pole Double Throw, SPDT, DPDT
Operation	Two and Three Position Maintained and Momentary
Knob Rotation	Two Position 60 Degrees Three Position 30 Degrees from Center
Illumination	LED; Red, Green, Amber, Yellow, White, Blue
Seals	LED O-ring(s) – Silicone, Bezel gasket – Neoprene, Knob seal - NBR
Flammability	Exceeds FVMSS 302 Requirements, Exterior Components, UL 94 V-2 or Better Interior Components, UL 94 HB or Better
Base	Polyester, PBT
Bracket	Nylon 66, PA
Knob	Polybutylene Terephthalate, PBT 6.5%GF
Lens	Polycarbonate, PC
Connector	Nylon 66, PA
Mounting	Front Panel Snap In, 1.450" (36.83mm) X 0.830" (21.08mm) Panel Thickness, 0.030" – 0.187" (0.76 – 4.75mm)

Mechanical

Mechanical Life	100,000 Cycles Maintained Circuits 50,000 Cycles Momentary Circuits
Knob Impact	50 Gram weight dropped from a height of 18 inches on Top & Sides

Environmental

Sealing	IP67, in accordance with IEC 60529, BS 5490, DIN 40050 & NFC 20 010. This rating applies to front panel components of the actual switch only, and signifies protection against dust and the prolonged effects of immersion under pressure.
Dust	Mil STD 810, Method 510.2 Air Velocity 300 Ft/Min Duration 16Hr
Corrosion	IEC 68-2-60 Mixed Flowing Gas (MFG) 14 Days
Chemical Splash	Gasoline, Diesel, Motor Oil, Brake Fluid, Ammonia, Armour All
Salt Spray	Mil STD 202G, Method 101, Test Condition A 96 Hr
Vibration Random	Mil STD 202G, Method 214 test Condition C 10G's RMS
Vibration Sinusoidal	Mil STD 202G, Method 204D, Test Condition A 0.06DA or 10G's 10-500Hz
Shock	MIL-STD 202G, Method 213B Test Condition K, 30G's 1 Meter Drop onto Hard Surface
Handling Shock	MIL-STD 202G, Method 107G Test Condition A -55 C to 85 C
Thermal Shock	MIL-STD 202G, Method 106F 10, 25 C to 65 C Cycles 95% RH
Moisture Resistance	25 Cycles -40 C to 85 C
Thermal Cycling	ISO 8846 with EC Directive 94/25/EC for Marine Products
Ignition Protection	300 hr Xenon Arc, 1.4W/m2 wavelength 420 nm
UV Protection	Human Static Discharge, +/- 15KV applied during normal operation
ESD	Shipping/Handling, frequency range 200-2000 MHz applied voltage is +8KV to +15KV and -8KV to -15KV 3 discharge cycles

*Manufacturer reserves the right to change product specification without prior notice.

Dimensional Specifications: in. [mm]

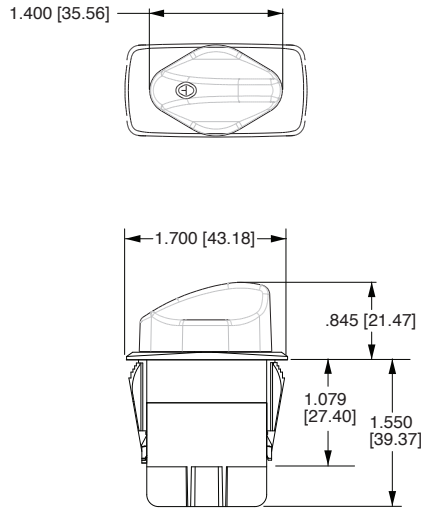

**10 TERMINAL BASE
W/ BARRIERS**

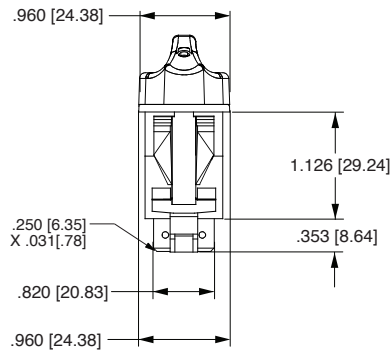

**10 TERMINAL BASE
W/O BARRIERS**

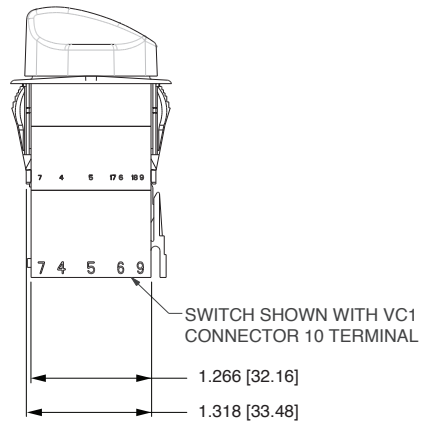
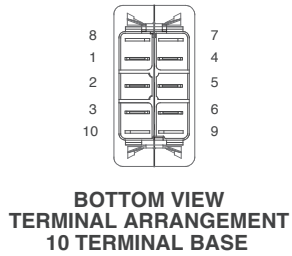

Circuits Codes

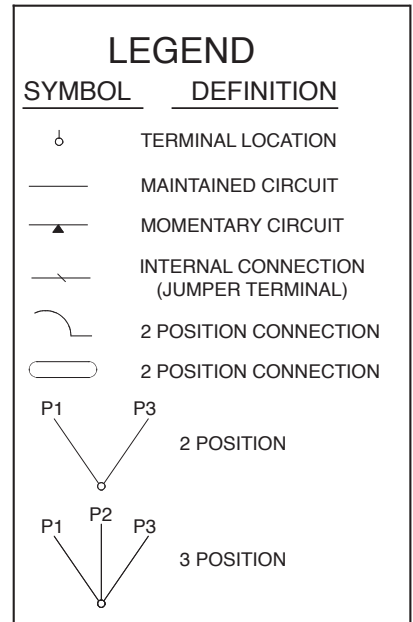
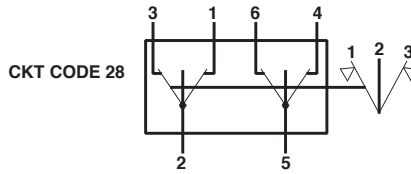
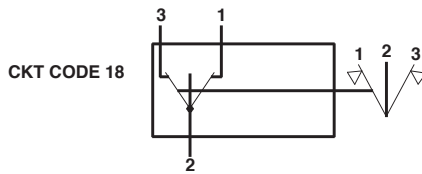
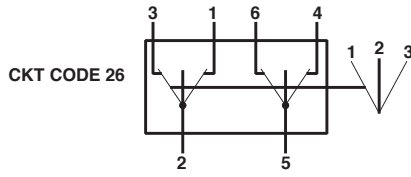
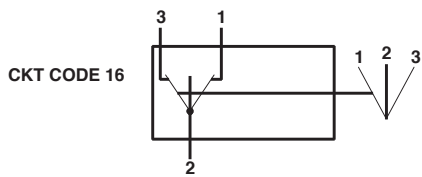
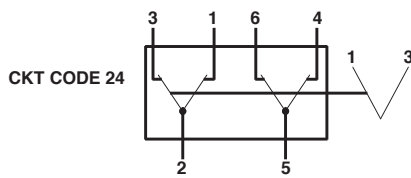
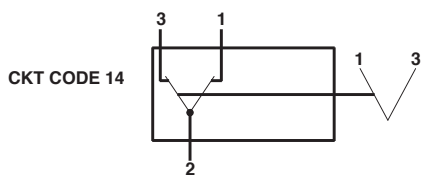
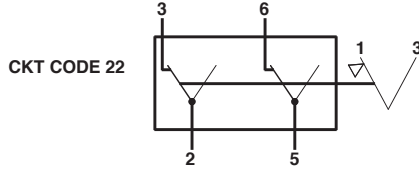
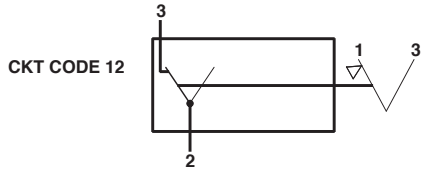
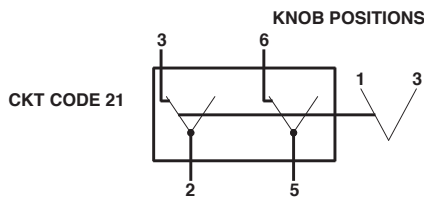
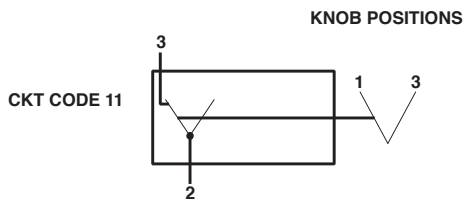

Standard Lamp Circuit Diagrams

LAMP CIRCUIT	CIRCUIT DIAGRAM	LAMP CIRCUIT	CIRCUIT DIAGRAM
A		L	
B		M	
C		N	
D		P	
E		R	
F		T	
G		U	
H		V	
J			
K			

RV 11 D 2 B C 0 0 B - K R C

1 Series 2 Circuit 3 Rating 4 Termination 5 Illumination 6 Lamp 1 7 Lamp 2 8 Lamp 3 9 Bracket 10 Actuator 11 Lens 12 Knob Color

1 SERIES
RV Rotary Contura

2 CIRCUIT¹

Terminal Connections as viewed () - momentary from bottom of switch:
 8 - -7 SP - single pole uses 1, 2 & 3.
 1 - -4 DP - double pole uses 1, 2, 3 and 4, 5, 6.
 2 - -5
 3 - -6
 10 - -9

Position:	1	2	3
SP DP	2 & 3, 5 & 6	Connected Terminals	1 & 2, 4 & 5
11 21	ON	NONE	OFF
12* 22	(ON)	NONE	OFF
(*Available Q2 - 2014)			
14 24	ON	NONE	ON
16 26	ON	OFF	ON
18 28	(ON)	OFF	(ON)

3 RATING

	External
1	.4VA 28VDC Resistive
B	15A 24V
D	20A 12V

4 TERMINATION/BASE STYLE

8 Term	10 Term	Termination	Jumper
1	2	.250 TAB (QC) - no barriers	No
A	B	.250 TAB (QC) - with barriers	No
3	4	Solder Lug - no barriers	No
C	D	Solder Lug	No
5	6	Wire Leads - no barriers	No
E	F	Wire Leads	No

5 ILLUMINATION²

Sealed	Lamps	when illuminated	Terminals
S	NONE		
A	# 1	Independent	8+ 7-
B	# 1	Dependent	3+ 7-
C	# 1	Independent	8+ 7-
D	& # 3	Independent	10+ 7-
E	# 1	Dependent	3+ 7-
F	& # 3	Dependent	1+ 7-
G	# 1	Independent	8+ 7-
H	# 2	Independent	9+ 7-
J	# 3	Independent	10+ 7-
K	# 1	Independent	3+ 7-
L	# 2	Independent	9+ 7-
M	# 3	Independent	1+ 7-
N	# 1	Independent	8+ 7-
P	# 2	Independent	9+ 7-
R	# 3	Independent	10+ 7-
T	# 1	Dependent	3+ 7-
U	# 2	Dependent	1+ 7-
V	# 3	Independent	10+ 7-
Single Pole Switches Only			
U	# 1	Dependent	3+ 6-
V	# 1	Dependent	3+ 6-
	# 3	Dependent	1+ 4-

6, 7, 8 LAMP#1, 2 AND OR LAMP #3⁴
 Selection 6: above terminal 7; Selection 8: above terminal 8

No lamp	Red	Amber	Green	Blue	White
0					
LED	C	N	H	E	6
12VDC	D	P	J	K	8
24VDC					

9 BRACKET COLOR & PANEL SEAL³

Color	No Gasket	1 Gasket	2 Gasket
Black	B	C	D
Gray	G	H	J
White	W	Y	Z

10 ACTUATOR STYLE

K Rotary Knob Standard

ACTUATOR ORIENTATION ABOVE TERMINALS



11 LENS COLOR⁴

No Actuation	No Lens	Clear	White	Amber	Green	Red	Blue
0	Z	4	9	E	K	R	W

12 KNOB COLOR

Black	Gray	Red
C	H	S

Notes:

- SP-single pole uses terminals 1,2 & 3. DP-double pole uses terminals 1,2,3,4,5 & 6. Terminals 7,8,9 & 10 are for lamp circuit only.
- Lamp #1 located at top end of switch, above terminal 4. Lamp #2 located at top end of switch between terminals 1 & 4. Lamp #3 located at top end of switch, above terminal 1. Positive (+) and negative (-) symbols apply to LED lamps only.
- Mounting hole size is 1.450" (36.83mm) by 0.830" (21.08mm). To mount multiple switches in single panel cut-out order optional interlocking mounting panels.
- Lens color for LEDs must be clear, white, or match color of LED.

Данный компонент на территории Российской Федерации

Вы можете приобрести в компании MosChip.

Для оперативного оформления запроса Вам необходимо перейти по данной ссылке:

<http://moschip.ru/get-element>

Вы можете разместить у нас заказ для любого Вашего проекта, будь то серийное производство или разработка единичного прибора.

В нашем ассортименте представлены ведущие мировые производители активных и пассивных электронных компонентов.

Нашей специализацией является поставка электронной компонентной базы двойного назначения, продукции таких производителей как XILINX, Intel (ex.ALTERA), Vicor, Microchip, Texas Instruments, Analog Devices, Mini-Circuits, Amphenol, Glenair.

Сотрудничество с глобальными дистрибьюторами электронных компонентов, предоставляет возможность заказывать и получать с международных складов практически любой перечень компонентов в оптимальные для Вас сроки.

На всех этапах разработки и производства наши партнеры могут получить квалифицированную поддержку опытных инженеров.

Система менеджмента качества компании отвечает требованиям в соответствии с ГОСТ Р ИСО 9001, ГОСТ РВ 0015-002 и ЭС РД 009

Офис по работе с юридическими лицами:

105318, г.Москва, ул.Щербаковская д.3, офис 1107, 1118, ДЦ «Щербаковский»

Телефон: +7 495 668-12-70 (многоканальный)

Факс: +7 495 668-12-70 (доб.304)

E-mail: info@moschip.ru

Skype отдела продаж:

moschip.ru

moschip.ru_4

moschip.ru_6

moschip.ru_9