

Power line communication AC coupling circuit

Data brief

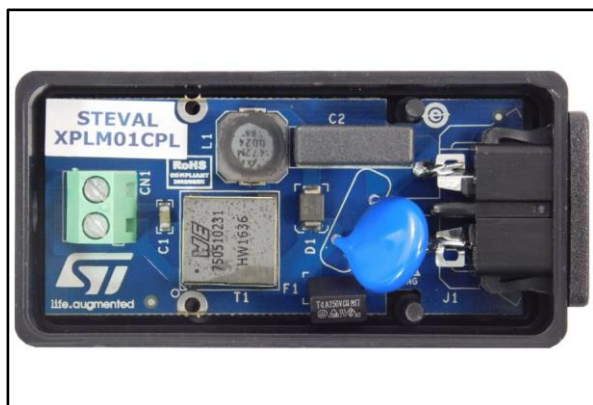

Features

- Complete AC coupling circuit suitable for use with any power line communication (PLC) solution
- Can be paired with the X-NUCLEO-PLM01A1 to add full AC coupling capability
- Tuned for transmission inside CENELEC B to D bands
- Implements isolation and protections for safe operation
- Suitable for the connection of laboratory equipment for PLC measurement and testing
- RoHS compliant

Description

The STEVAL-XPLM01CPL is a simple yet very useful tool for power line communication testing on AC power networks.

It includes simple two-wire connectivity to any PLC transmitter/receiver and a standard connector for an AC power cord (2-pin AC plug, 8-shape female end). The main components to achieve suitable signal coupling are:

- PLC 1:1 transformer for differential coupling and basic electrical isolation
- SM6T15CA 600 W Transil +320 V ac varistor for effective protection against ESD, EFT and surge disturbances from the power line
- High voltage AC blocking capacitor with X2 safety class
- Tuning series inductor to adjust the frequency response

The STEVAL-XPLM01CPL can be very easily interfaced with the X-NUCLEO-PLM01A1 to test PLC communication performance over an AC mains network.

The frequency response of the coupling circuit is wide enough to fit any narrow-band PLC signal under normal test conditions. However, it can be easily adjusted by changing only the tuning series inductor L1.

The STEVAL-XPLM01CPL is suitable for lab measurements using equipment like an isolated probe for an oscilloscope or a spectrum analyzer, or to inject a signal from an arbitrary function generator.

1 Schematic diagram

Figure 1: STEVAL-XPLM01CPL circuit schematic

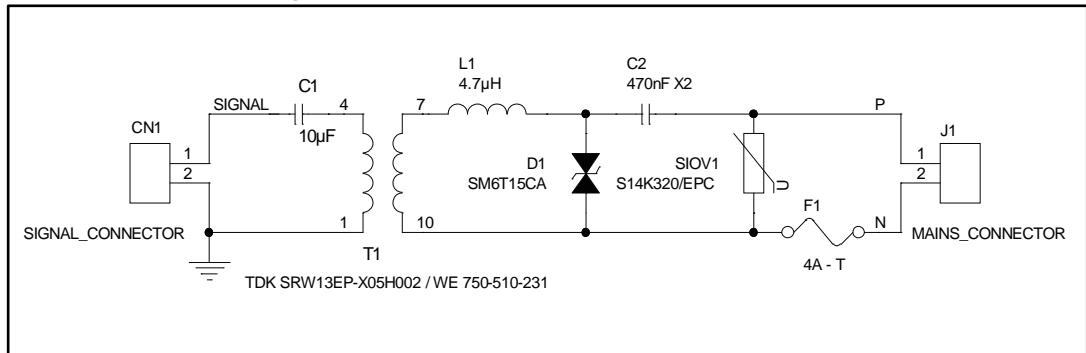

IMPORTANT – Safety recommendations

The STEVAL-XPLM01CPL must be used by expert technicians only. Due to the high voltage (85 - 265 Vac) present on the non-isolated parts, special care must be taken in order to avoid electric risks for people safety.

There are no protections against high voltage accidental human contact.

After disconnection of the board from the mains, no live part can be touched immediately because of the energized capacitor.

Do not connect any instrument probe to high voltage parts if the board is not isolated from the mains supply, in order to avoid damaging any equipment.

ST assumes no responsibility for the consequences of any improper use of this development tool.

2 Revision history

Table 1: Document revision history

Date	Version	Changes
06-Jun-2017	1	Initial release.

IMPORTANT NOTICE – PLEASE READ CAREFULLY

STMicroelectronics NV and its subsidiaries ("ST") reserve the right to make changes, corrections, enhancements, modifications, and improvements to ST products and/or to this document at any time without notice. Purchasers should obtain the latest relevant information on ST products before placing orders. ST products are sold pursuant to ST's terms and conditions of sale in place at the time of order acknowledgement.

Purchasers are solely responsible for the choice, selection, and use of ST products and ST assumes no liability for application assistance or the design of Purchasers' products.

No license, express or implied, to any intellectual property right is granted by ST herein.

Resale of ST products with provisions different from the information set forth herein shall void any warranty granted by ST for such product.

ST and the ST logo are trademarks of ST. All other product or service names are the property of their respective owners.

Information in this document supersedes and replaces information previously supplied in any prior versions of this document.

© 2017 STMicroelectronics – All rights reserved

Данный компонент на территории Российской Федерации

Вы можете приобрести в компании MosChip.

Для оперативного оформления запроса Вам необходимо перейти по данной ссылке:

<http://moschip.ru/get-element>

Вы можете разместить у нас заказ для любого Вашего проекта, будь то серийное производство или разработка единичного прибора.

В нашем ассортименте представлены ведущие мировые производители активных и пассивных электронных компонентов.

Нашей специализацией является поставка электронной компонентной базы двойного назначения, продукции таких производителей как XILINX, Intel (ex.ALTERA), Vicor, Microchip, Texas Instruments, Analog Devices, Mini-Circuits, Amphenol, Glenair.

Сотрудничество с глобальными дистрибьюторами электронных компонентов, предоставляет возможность заказывать и получать с международных складов практически любой перечень компонентов в оптимальные для Вас сроки.

На всех этапах разработки и производства наши партнеры могут получить квалифицированную поддержку опытных инженеров.

Система менеджмента качества компании отвечает требованиям в соответствии с ГОСТ Р ИСО 9001, ГОСТ РВ 0015-002 и ЭС РД 009

Офис по работе с юридическими лицами:

105318, г.Москва, ул.Щербаковская д.3, офис 1107, 1118, ДЦ «Щербаковский»

Телефон: +7 495 668-12-70 (многоканальный)

Факс: +7 495 668-12-70 (доб.304)

E-mail: info@moschip.ru

Skype отдела продаж:

moschip.ru

moschip.ru_4

moschip.ru_6

moschip.ru_9