

Data Sheet

LL01CR-CEWxxL52

CREE 
▶ LED Solution Provider



■ Features & Typical Applications

- High efficiency
- Available with 3 beam angles
- Optimized Uniformity
- Lens with Connector
- Architectural Lighting
- Commercial Lighting
- Spotlight

■ Table of Contents

General Information & Product Nomenclature.....	P.2
Optical Specifications	P.3
Mechanical Specifications.....	P.4
Package Specifications	P.5

LL01CR-CEWxxL52

General Information

- Lens Material : SABIC 2180T
- Connector Material : PBT4815
- Operating Temperature range -40°C~+110°C(upper limit +120°C).
- Storage Temperature range -40°C~+110°C(upper limit +120°C).
 - * Average transmittance in visible spectrum 400nm~700nm>90%.
- Usage and Maintenance:
 1. If necessary, clean lenses with mild soap, water and soft cloth.
 2. Never use any commercial cleaning solvents on lenses, like alcohol.
 3. Please handle or install lenses with wearing gloves, skin oils may damage lens or its optical characteristic.

Product Nomenclature

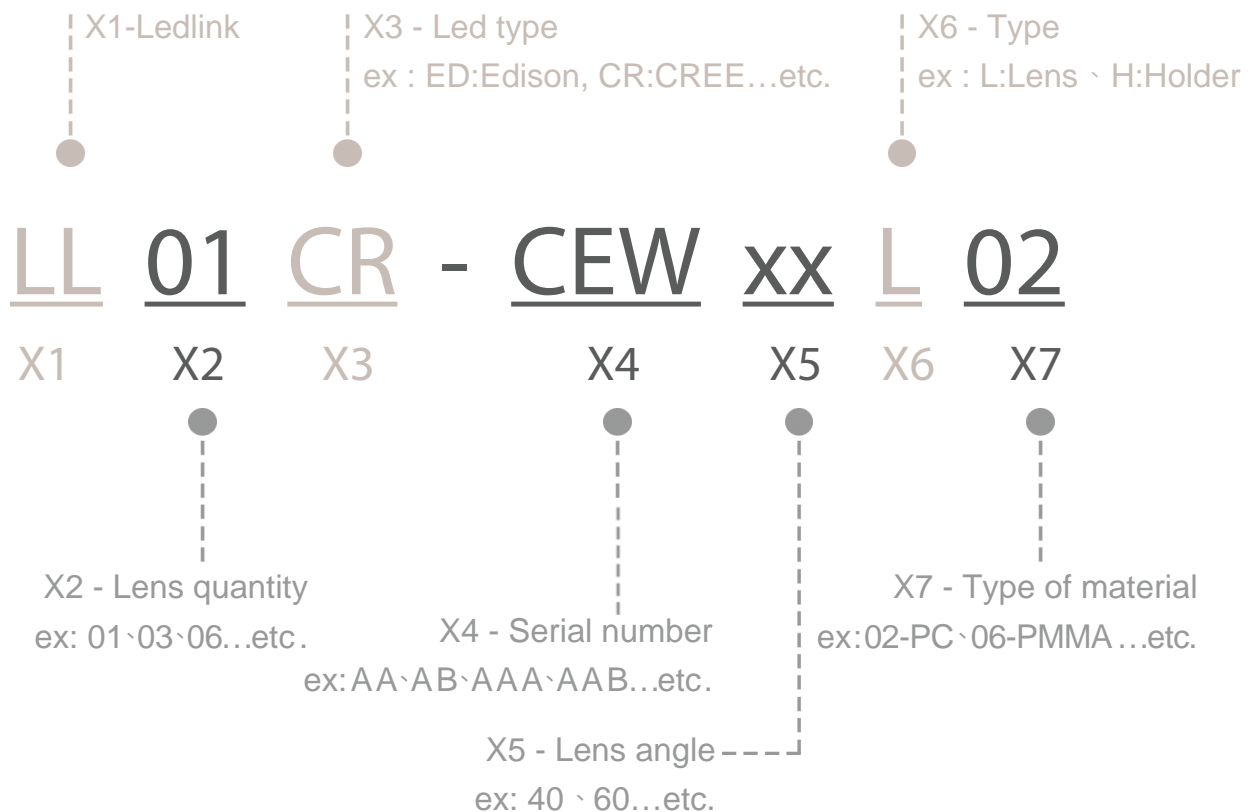

LL01CR-CEWxxL52 Optical Specifications

CREE 
LED Solution Provider



CXA1310

Note: (1) All the results of analysis are based on 0 degrees of elevation.
(2) Tolerance: $\pm 10\%$.
(3) Led Luminous Flux(lm): 330($\pm 5\%$).

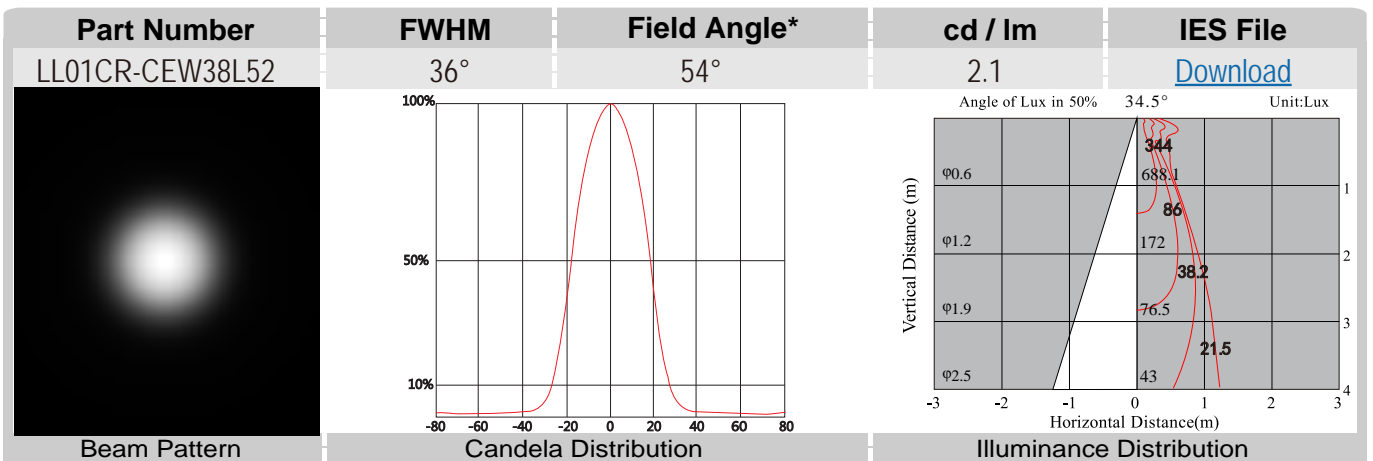
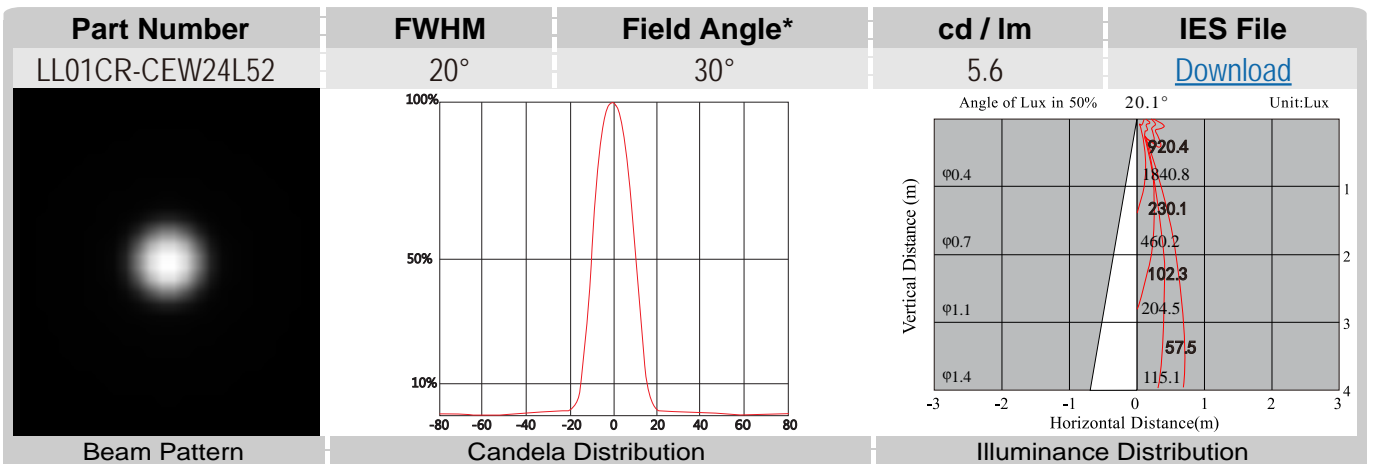
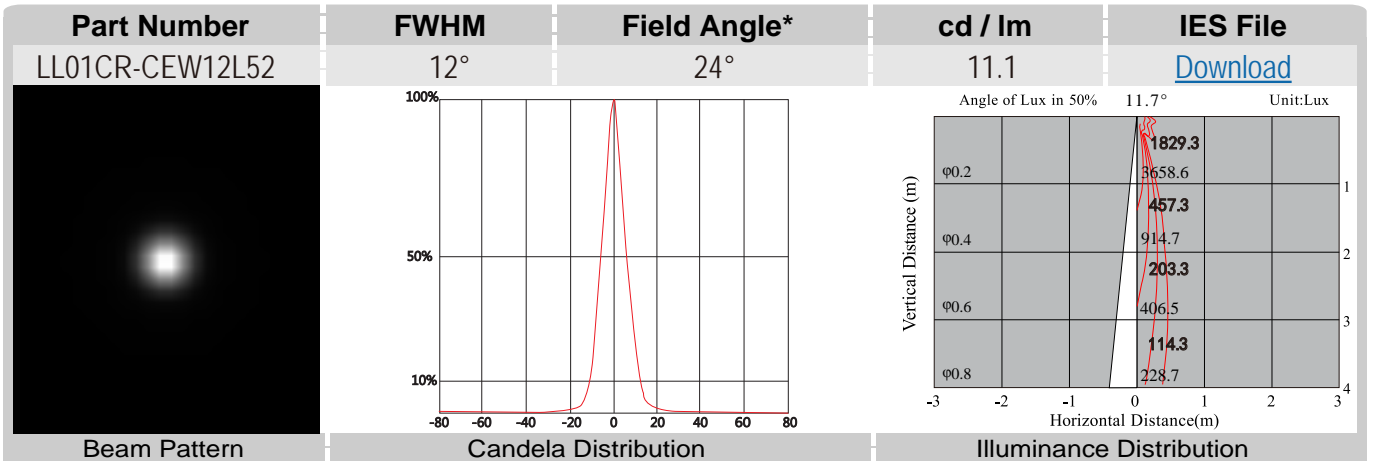

*The Field Angle is the angle between the two directions opposed to each other over the beam axis for which the luminous intensity is 10% that of the maximum luminous intensity.
*This testing result is obtained through testing the popular rank LED samples which provided by the original manufacturer. Hence, the testing results would be varied as the users choose same LED model but different rank.

LL01CR-CEWxxL52 Optical Specifications

CREE 
 LED Solution Provider



CXA1310

Note: (1) All the results of analysis are based on 0 degrees of elevation.
 (2) Tolerance: $\pm 10\%$.
 (3) Led Luminous Flux(lm): 330($\pm 5\%$).

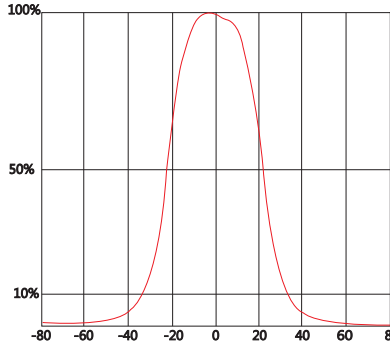
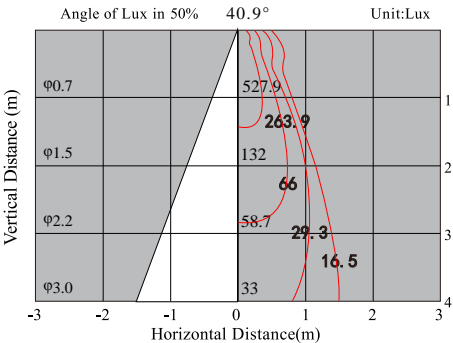
Part Number	FWHM	Field Angle*	cd / lm	IES File
LL01CR-CEW45L52	44.6°	68.7°	1.4	Download
				
Beam Pattern	Candela Distribution		Illuminance Distribution	

*The Field Angle is the angle between the two directions opposed to each other over the beam axis for which the luminous intensity is 10% that of the maximum luminous intensity.
 *This testing result is obtained through testing the popular rank LED samples which provided by the original manufacturer. Hence, the testing results would be varied as the users choose same LED model but different rank.

LL01CR-CEWxxL52 Mechanical Specification

1. Fixing method

 Glue

 Screw

 Tape

 Fixing-ring

 Frame

Note: (1) All dimensions are in mm.
 (2) All tolerance are ± 0.15 mm unless otherwise specified.

2. Lens dimension

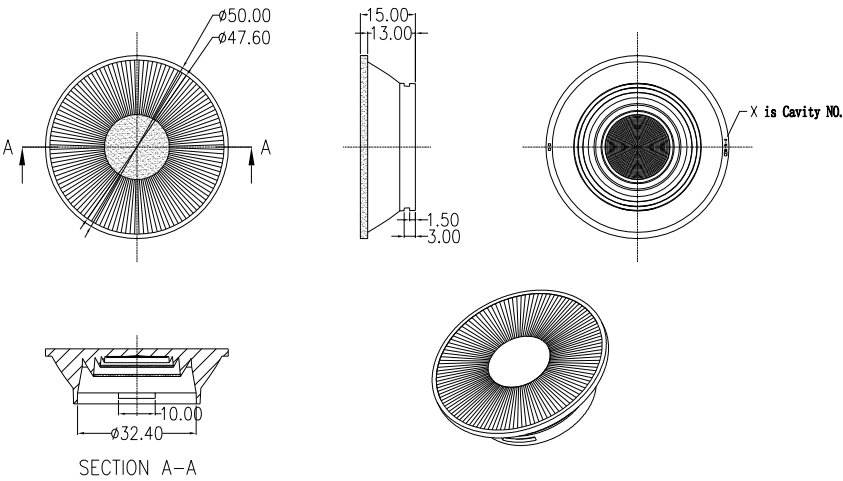

3. Lens + Leds assembly instruction

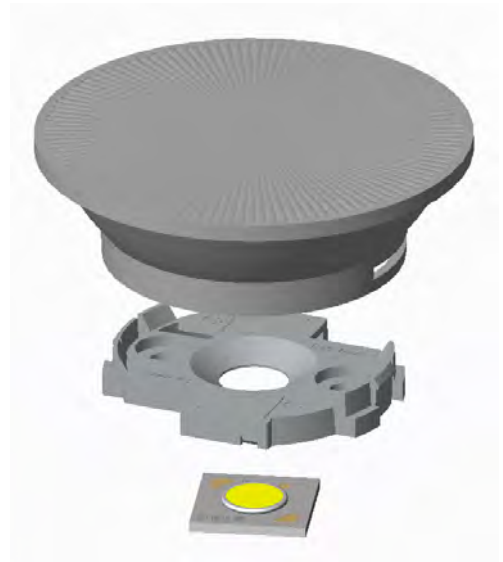

4. Connector dimension

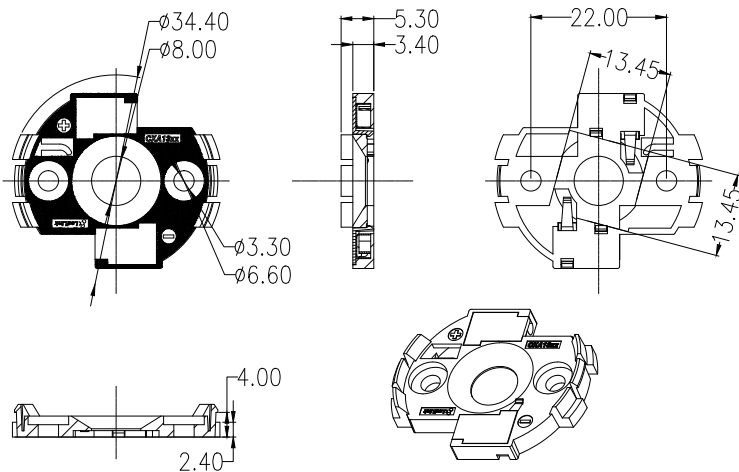

5. View assembly lens with LED:

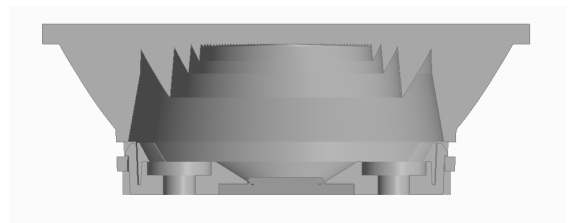

Connector part number: LL01A00CZNB2-M2

LL01CR-CEWxxL52 Package Specifications

Item	Quantity	Total	Size(L*W*H)	G.W
plastic box	25 pcs/plastic box	25 pcs	32*29*2.05 cm	12.9g
outer box	10 plastic box/outer box	250 pcs	35*31*21 cm	

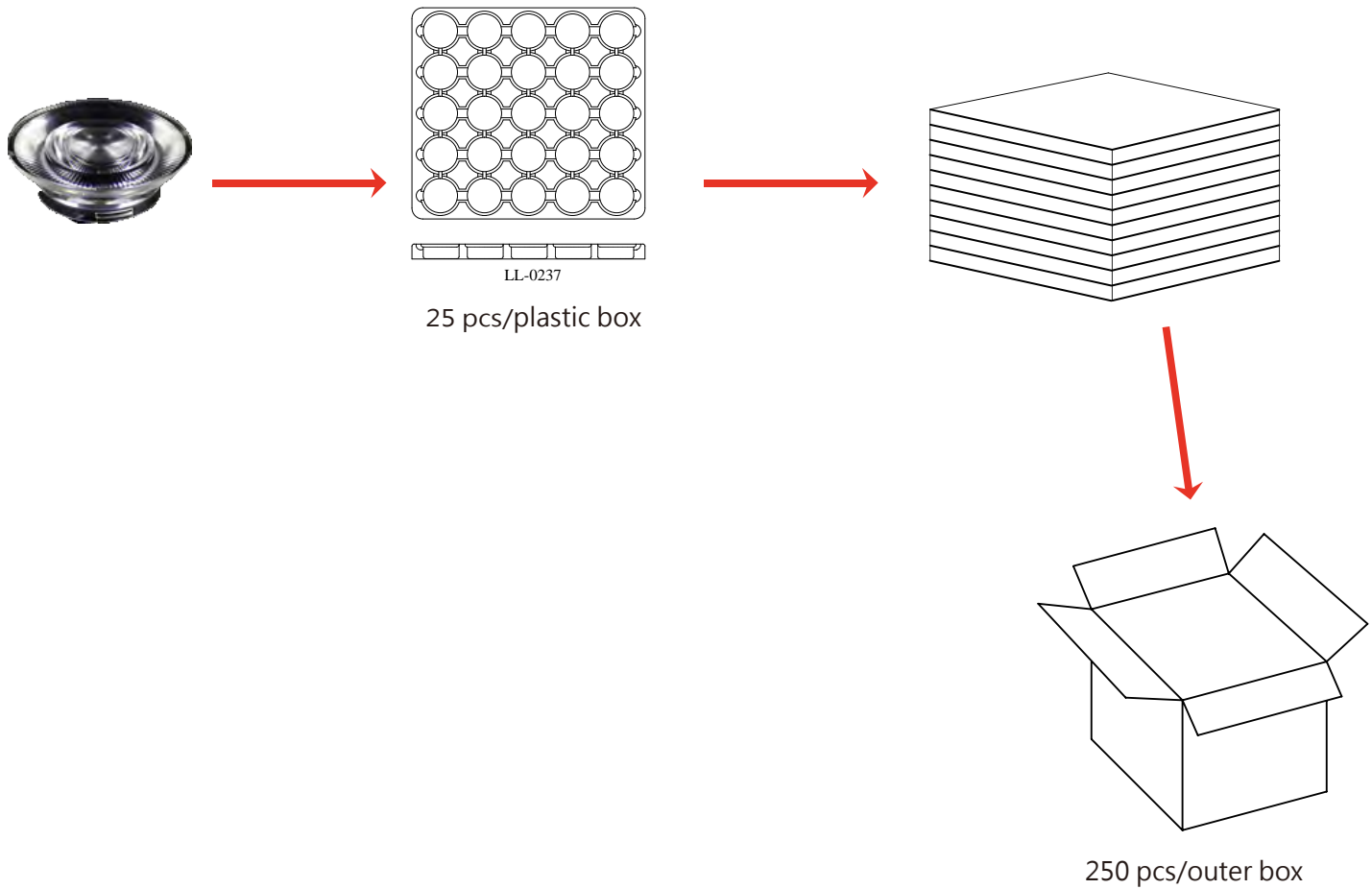

Note:

LL01CR-CEWxxL52 Package Specifications

Item	Quantity	Total	Size(L*W*H)	G.W
plastic box	64pcs/plastic box	64 pcs	32*29.3*1.4 cm	1.5g
outer box	14 plastic box/outer box	896 pcs	41*38*21 cm	

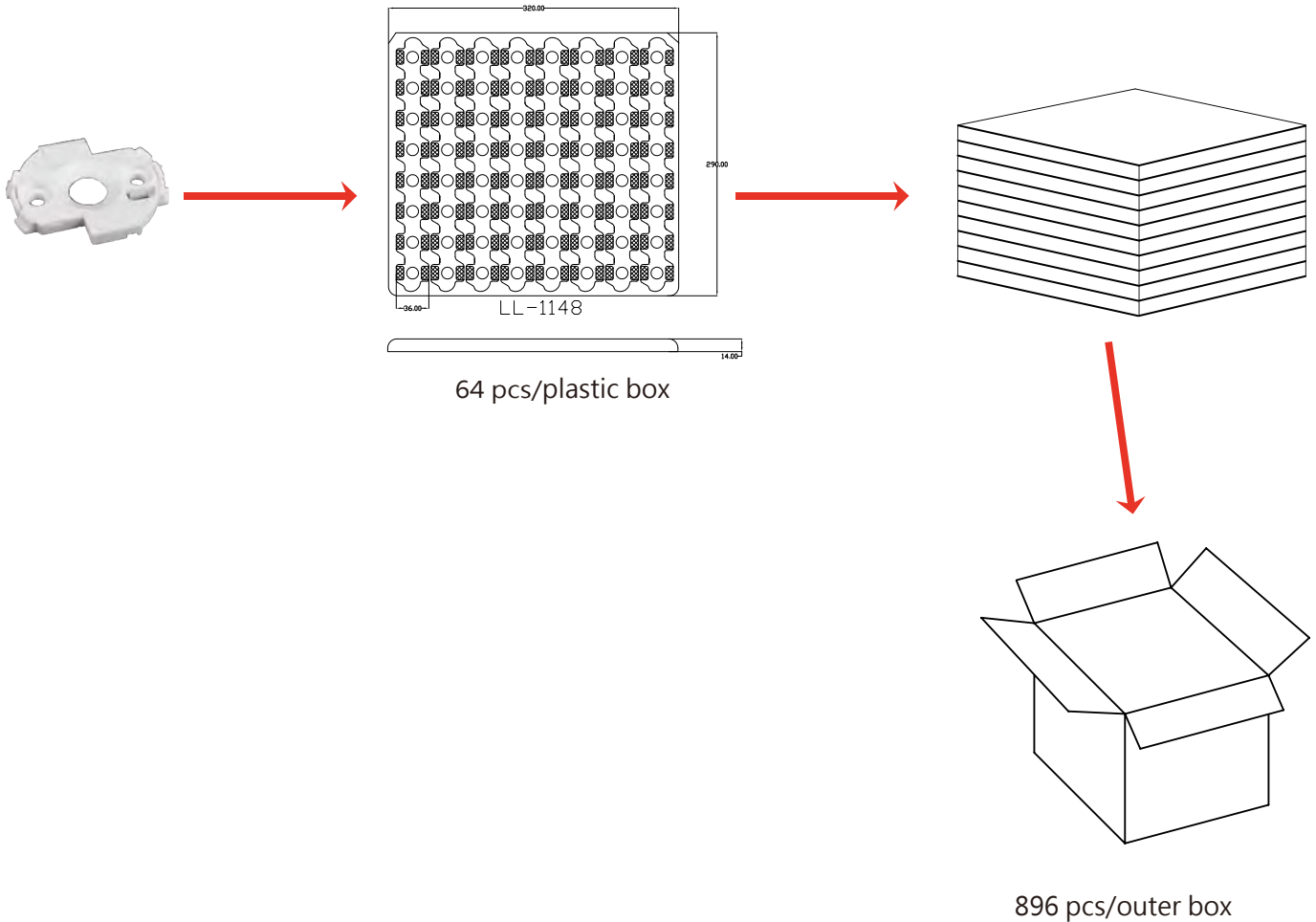

Note:

Данный компонент на территории Российской Федерации

Вы можете приобрести в компании MosChip.

Для оперативного оформления запроса Вам необходимо перейти по данной ссылке:

<http://moschip.ru/get-element>

Вы можете разместить у нас заказ для любого Вашего проекта, будь то серийное производство или разработка единичного прибора.

В нашем ассортименте представлены ведущие мировые производители активных и пассивных электронных компонентов.

Нашей специализацией является поставка электронной компонентной базы двойного назначения, продукции таких производителей как XILINX, Intel (ex.ALTERA), Vicor, Microchip, Texas Instruments, Analog Devices, Mini-Circuits, Amphenol, Glenair.

Сотрудничество с глобальными дистрибьюторами электронных компонентов, предоставляет возможность заказывать и получать с международных складов практически любой перечень компонентов в оптимальные для Вас сроки.

На всех этапах разработки и производства наши партнеры могут получить квалифицированную поддержку опытных инженеров.

Система менеджмента качества компании отвечает требованиям в соответствии с ГОСТ Р ИСО 9001, ГОСТ РВ 0015-002 и ЭС РД 009

Офис по работе с юридическими лицами:

105318, г.Москва, ул.Щербаковская д.3, офис 1107, 1118, ДЦ «Щербаковский»

Телефон: +7 495 668-12-70 (многоканальный)

Факс: +7 495 668-12-70 (доб.304)

E-mail: info@moschip.ru

Skype отдела продаж:

moschip.ru

moschip.ru_4

moschip.ru_6

moschip.ru_9