

ISDN S-INTERFACE LOW PROFILE DUAL SMT TRANSFORMERS

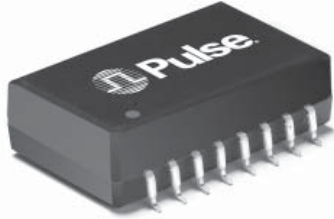

- RoHS peak reflow temperature rating 245°C
- Meets pulse waveform template of CCITT I.430 when recommended transformer and chip pair are used
- Excellent longitudinal balance
- 2 KVRms isolation voltage
- Available in Tape & Reel or tube packaging
- UL recognized

Electrical Specifications @ 25°C — Operating Temperature 0°C to 70°C

RoHS Compliant Part Number	Ratio ^A (±2%)		OCL Pri (mH MIN)	L _L Sec (μH MAX)		CW/W (pF MAX)	CD Pri ^B (pF MAX)		DCR Pri (Ω ±25%)		DCR Sec (W ±25%)		D _{Ibc} ^C (mA MAX)
	A	B	A & B	A	B	A & B	A	B	A	B	A	B	
T5005NL	1:2.5	1:2.5	22	40	40	100	110	110	2.4	2.4	5.3	5.3	1
T5007NL	1:2	1:2	22	5	5	100	80	80	2.4	2.4	4.2	4.2	1
T5008NL	1:1	1:1	22	5	5	100	42	42	2.4	2.4	2.4	2.4	1
T5010NL	1:1.8	1:1.8	22	15	15	100	160	160	2.4	2.4	3.8	3.8	1

U.S. Patent No. 5,015,981Z

- A. A center-tapped** winding can be created by connecting two ends of a split center winding together on the printed circuit board. In ISDN-S applications, the primary winding is the line side transformer winding.
- B. Minimum primary** inductance and maximum distributed capacitance satisfy the transmitter output and receiver input impedance requirements of CCITT I.430 for both the TE and the NT. The maximum distributed capacitance allows sufficient margin for the capacitance of the IC and a protection diode network. It is consistent with the overall maximum value specified and the permitted length of the basic access TE cord.
- C. The maximum** specified unbalanced DC current capability is based on 20 mH minimum primary OCL.

See next page for detailed packaging information.

Mechanical

TSJ

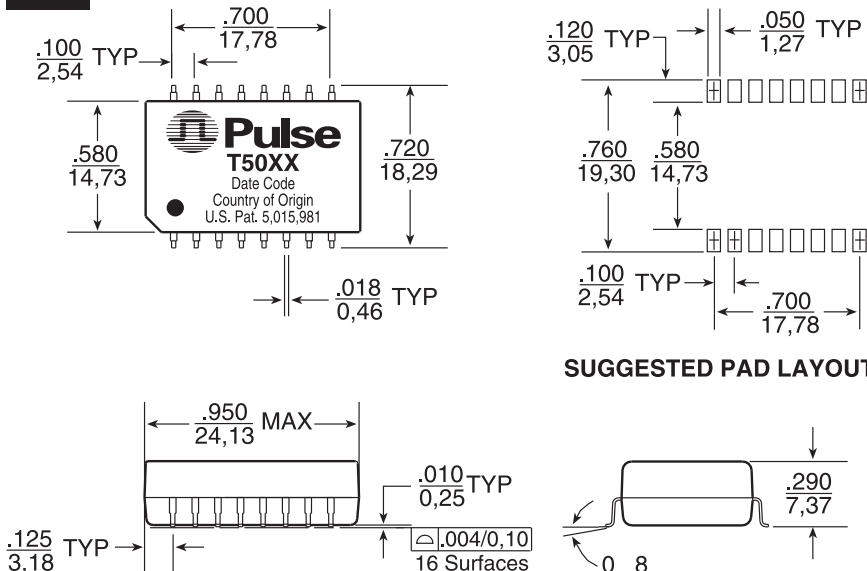

SUGGESTED PAD LAYOUT

Schematic

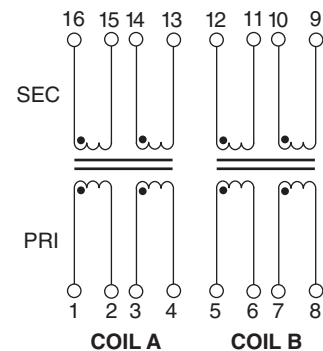

Dimensions: $\frac{\text{Inches}}{\text{mm}}$
Unless otherwise specified all tolerances are $\pm .010$
0,25

ISDN S-INTERFACE LOW PROFILE DUAL SMT TRANSFORMERS



IC Manufacturer	IC Part Number	Dual Surface Mount
TX & RX		
AT&T/Lucent	T7250/7256/7259 T7903	T5005NL T5007NL
Mietec	MTC-2072	T5007NL
Mitel	MT8930	T5007NL
Motorola	MC145474/145475 MC145574	T5008NL T5005NL
National*	TP3420/3421	T5007NL
SGS Thomson	ST5420, ST5421	T5007NL
Siemens	PEB 2080/2081/2085 PSB 2186 PEB 2084/2086	T5007NL
Yamaha	7405B, YTD421	T5007NL
B	29C53	T5010NL

*NOTE: National recommends a 1:2 receive transformer, but used as a 1:1 ratio by connecting only half the secondary winding.

Packaging Information	
Type	SMT
Part Weight	7 grams
Parts/Tube	20
Parts/Tray*	50
Parts/Reel*	200
Reel Diameter	13 inches
Tape Width	44 mm
Pitch	24 mm

*NOTE: Standard packaging for all transformers on this data sheet is anti-static tubes. Optional Tape & Reel packaging can be ordered by adding a "T" suffix to the end of the part number, (i.e: T5005NLT).

Application Notes

1. General Information – The S-interface is the standardized four-wire digital telephone access point defined by the CCITT I-series recommendations for the Integrated Services Digital Network. This "basic rate access" accommodates two 64 Kbps "B-channels" for information, one 16Kbps "D-channel" intended for signaling and control, and 48Kbps for framing and other purposes, giving a total rate of 192Kbps. The CCITT physical layer recommends that the user network interface be transformer coupled.

The transformer provides isolation for the line card or the terminal from the line. It is also a way to provide phantom power feeding to the terminal over the S-loop. Each end requires a transmit and a receive transformer. Chokes are used in some applications to reduce common mode noise.

Transformers described in this data sheet are matched to the transceivers offered by the IC manufacturers listed.

The use of a transformer-chip pair assures that all requirements of CCITT I.430 are met with respect to pulse waveform templates, impedance and longitudinal balance. In addition, the transformers provide the isolation voltages required by the regulatory agencies and are capable of passing surge voltage tests.

- 2. Safety Standards Recognition** – All transformers listed in this data sheet are recognized to UL 1459 and UL 1950 as a basic insulation barrier.
- 3. Flammability** – Materials used in the products are recognized UL94-VO. Products meet the requirements of IEC 695-2-2 (needle flame test).
- 4. For more** application notes please refer to data sheet T604.

Common Mode Chokes

Refer to data sheet G002 for selection of low and high frequency common mode chokes.

For More Information:

Pulse Worldwide Headquarters

12220 World Trade Dr.
San Diego, CA 92128
U.S.A.

www.pulseeng.com

Tel: 858 674 8100
Fax: 858 674 8262

Pulse Europe

Einsteinstrasse 1
D-71083 Herrenberg
Germany

Tel: 49 7032 7806 0
Fax: 49 7032 7806 135

Pulse China Headquarters

B402, Shenzhen Academy of
Aerospace Technology Bldg.
10th Kejinan Rd.
High-Tech Zone
Nanshan District
Shenzhen, PR China 518057

Tel: 86 755 33966678
Fax: 86 755 33966700

Pulse North China

Room 2704/2705
Super Ocean Finance Ctr.
2067 Yan An Rd. West
Shanghai 200336
China

Tel: 86 21 62787060
Fax: 86 2162786973

Pulse South Asia

135 Joo Seng Rd.
#03-02
PM Industrial Bldg.
Singapore 368363

Tel: 65 6287 8998
Fax: 65 6287 8998

Pulse North Asia

3F, No. 198
Zhongyuan Rd.
Zhongli City
Taoyuan County 320
Taiwan R. O. C.

Tel: 886 3 4356768
Fax: FRE 886 3 4356820
Pulse: 886 3 4356823

Performance warranty of products offered on this data sheet is limited to the parameters specified. Data is subject to change without notice. Other brand and product names mentioned herein may be trademarks or registered trademarks of their respective owners.

© Copyright, 2009. Pulse Engineering, Inc. All rights reserved.

www.pulseeng.com

Данный компонент на территории Российской Федерации

Вы можете приобрести в компании MosChip.

Для оперативного оформления запроса Вам необходимо перейти по данной ссылке:

<http://moschip.ru/get-element>

Вы можете разместить у нас заказ для любого Вашего проекта, будь то серийное производство или разработка единичного прибора.

В нашем ассортименте представлены ведущие мировые производители активных и пассивных электронных компонентов.

Нашей специализацией является поставка электронной компонентной базы двойного назначения, продукции таких производителей как XILINX, Intel (ex.ALTERA), Vicor, Microchip, Texas Instruments, Analog Devices, Mini-Circuits, Amphenol, Glenair.

Сотрудничество с глобальными дистрибьюторами электронных компонентов, предоставляет возможность заказывать и получать с международных складов практически любой перечень компонентов в оптимальные для Вас сроки.

На всех этапах разработки и производства наши партнеры могут получить квалифицированную поддержку опытных инженеров.

Система менеджмента качества компании отвечает требованиям в соответствии с ГОСТ Р ИСО 9001, ГОСТ РВ 0015-002 и ЭС РД 009

Офис по работе с юридическими лицами:

105318, г.Москва, ул.Щербаковская д.3, офис 1107, 1118, ДЦ «Щербаковский»

Телефон: +7 495 668-12-70 (многоканальный)

Факс: +7 495 668-12-70 (доб.304)

E-mail: info@moschip.ru

Skype отдела продаж:

moschip.ru

moschip.ru_4

moschip.ru_6

moschip.ru_9