

C14 IEC Fused Inlet - Polyflange

VERTICAL MODULE ARRANGEMENT

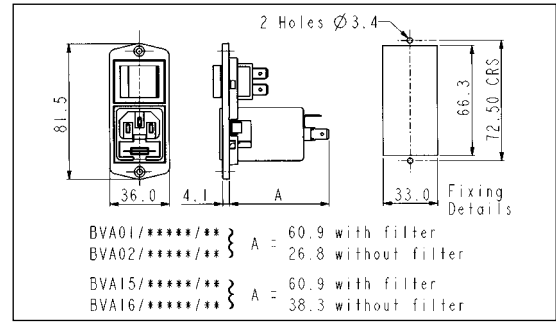

- Fused Inlet with 2.8mm or 6.3mm tags
- Screw Fixing to Panel
- Double Pole Switch Variations
- Filtered Inlet Option
- Options of I/O marked switches



VERTICAL MODULE ARRANGEMENT



- Fused Inlet with 2.8mm or 6.3mm tags
- Screw Fixing to Panel
- Double Pole Switch Variations
- Filtered Inlet Option
- Options of I/O marked switches

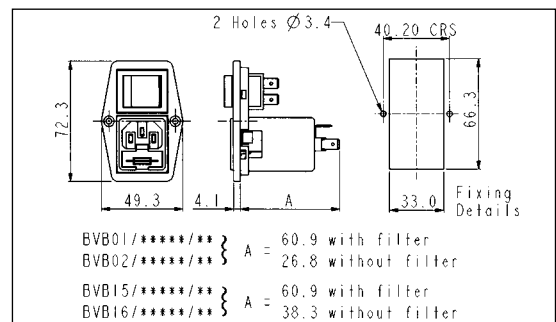

How to Order

BVx xx / xxxxx / xx

Flange Type	Type of Inlet / Outlet	Filtered or Non Filtered Inlet	Combination of Other Components
<p>A = Top fixing</p> <p>B = Side fixing</p>	<p>Fused C14 Power Inlet (cold condition), 6.3 or 2.8mm tabs:</p> <p>01 = PF0011/63 02 = PF0011/28</p> <p>Twin Fused C14 Power Inlet (cold condition), 6.3 or 2.8mm tabs:</p> <p>15 = PF0033/63 16 = PF0033/28</p>	<p>Z0000 = Non Filtered</p> <p>Axxxx = Standard</p> <p>Bxxxx = Medical</p> <p>Cxxxx = High Performance Standard (Single Fuse Version only)</p> <div style="border: 1px solid black; padding: 5px; margin-top: 10px;"> <p>For Filtered inlet use 6th to 9th characters from filter ordering code see pages 115-118.</p> <p>E.g. BVA01/A0620/10</p> </div>	<p>Neon Indicator:</p> <p>D3 = Red Neon Indicator</p> <p>Double Pole Switch:</p> <p>10 = D.P. Switch</p> <p>Double Pole Neon Switch:</p> <p>11 = D.P. Red Neon Switch 12 = D.P. Green Neon Switch</p> <p>Double Pole High Inrush Switch:</p> <p>13 = D.P. High Inrush Switch</p> <p>Double Pole Switch Marked I/O:</p> <p>70 = D.P. Switch (I/O)</p> <p>Double Pole Neon Switch Marked (I/O):</p> <p>76 = D.P. Red Neon Switch (I/O) 77 = D.P. Green Neon Switch (I/O)</p> <p>Double Pole High Inrush Switch Marked (I/O):</p> <p>78 = D.P. High Inrush Switch (I/O) B1 = D.P. High Inrush Green Neon Switch (I/O)</p>

Note: For technical details of individual components please see page 92

Components used in Polysnap® and Polyflange Power Inlet Modules

Note: Components are Approved Individually (where applicable). Please see individual component pages for full specifications.

IEC CONNECTORS, FUSEHOLDERS AND VOLTAGE SELECTORS

Type	Description	Rating	Approvals
DX0928	Neon Indicator	110V or 250V a.c./d.c. working	
FX0359	5 x 20mm Fuseholder	Max. rating 10A. 250V See Page 156	
PF0011	C14 Power Inlet with Integral 5 x 20mm Fuseholder	Max. rating 10A. 250V a.c. See Page 67	
PF0033	C14 Power Inlet with Integral twin 5 x 20mm Fuseholder	Max. rating 10A. 250V a.c. See Page 68	
PX0575	C14 Power Inlet, Cold condition	Max. rating 10A. 250V a.c. See Page 63	
PX0595	C16 Power Inlet, Hot Condition	Max. rating 10A. 250V a.c. See Page 69	
PX0695	Sheet F Power Outlet	Max. rating 10A. 250V a.c. See Page 76	
PX0783	Sheet F Shuttered Power Outlet	Max. rating 10A. 250V a.c. See Page 77	
PX0598	C20 Power Inlet	Max. rating 16A, 250V a.c. See Page 79	
VS0001	Voltage Selector marked 120/240V	Max. rating 6.3A. 120/240V a.c. See Page 196	

IEC CONNECTORS

SWITCHES, INDICATORS AND CIRCUIT BREAKERS

No Poles	Illumination	Current Ratings	Circuit	Approvals
Single Pole	Non-illuminated	Max. rating 16A Resistive, 4A Inductive, 250Vac.		
	High Inrush	Max. rating 16A Resistive, 4A Inductive, 250Vac. Inrush current, 150A to IEC65.		
Double Pole	Illuminated	Max. rating 16A Resistive, 4A Inductive, 250Vac.		
	Non-illuminated	Max. rating 16A Resistive, 4A Inductive, 250Vac. Inrush current, 150A to IEC65.		
	High Inrush	Max. rating 16A Resistive, 4A Inductive, 250Vac. Inrush current, 150A to IEC65.		
For Mini Bezel: Single Pole	Non-illuminated	Max. rating 10A Resistive, 4A Inductive, 250Vac.		
	Illuminated	Max. rating 10A Resistive, 4A Inductive, 250Vac. 250Vac Neon.		
Double Pole	Non-illuminated	Max. rating 10A Resistive, 4A Inductive, 250Vac.		
	High Inrush	Max. rating 10A Resistive, 4A Inductive, 250Vac. Inrush current, 85A to EN61058-1.		
	Illuminated	Max. rating 10A Resistive, 4A Inductive, 250Vac. 250Vac Neon.		
Indicator		250Vac neon lamp connected internally to terminals.		
Circuit Breaker	Non-illuminated			
	Illuminated	125Vac and 250Vac Neons.		

RoHS Polysnap and Polyflange range and all components are compliant

Данный компонент на территории Российской Федерации

Вы можете приобрести в компании MosChip.

Для оперативного оформления запроса Вам необходимо перейти по данной ссылке:

<http://moschip.ru/get-element>

Вы можете разместить у нас заказ для любого Вашего проекта, будь то серийное производство или разработка единичного прибора.

В нашем ассортименте представлены ведущие мировые производители активных и пассивных электронных компонентов.

Нашей специализацией является поставка электронной компонентной базы двойного назначения, продукции таких производителей как XILINX, Intel (ex.ALTERA), Vicor, Microchip, Texas Instruments, Analog Devices, Mini-Circuits, Amphenol, Glenair.

Сотрудничество с глобальными дистрибьюторами электронных компонентов, предоставляет возможность заказывать и получать с международных складов практически любой перечень компонентов в оптимальные для Вас сроки.

На всех этапах разработки и производства наши партнеры могут получить квалифицированную поддержку опытных инженеров.

Система менеджмента качества компании отвечает требованиям в соответствии с ГОСТ Р ИСО 9001, ГОСТ РВ 0015-002 и ЭС РД 009

Офис по работе с юридическими лицами:

105318, г.Москва, ул.Щербаковская д.3, офис 1107, 1118, ДЦ «Щербаковский»

Телефон: +7 495 668-12-70 (многоканальный)

Факс: +7 495 668-12-70 (доб.304)

E-mail: info@moschip.ru

Skype отдела продаж:

moschip.ru

moschip.ru_4

moschip.ru_6

moschip.ru_9