

Features

- Suitable for High Power Military and Civilian Radio Applications
- Power Handling: 100 W @ 85°C
- Insertion Loss: 0.35 dB @ 2 GHz
- Isolation: 40 dB @ 2 GHz
- Surface Mount 7 mm 16-lead HQFN Package
- RoHS* Compliant and 260°C Reflow Compatible
- Class 1B HBM ESD Rating

Description

The MASW-011030 is a high power PIN diode SP3T switch in a common anode configuration, operating from 30 MHz to 3 GHz. It features low insertion loss and excellent linearity with low DC consumption. This device is capable of handling 100 Watts CW incident power at a base plate temperature of 85°C.

This high power switch is ideal for use on land mobile radio and MIL-COM applications that require higher CW and pulsed power operation.

The MASW-011030 is manufactured using MACOM's hybrid manufacturing process featuring high voltage PIN diodes and passive devices integrated in a 7 mm HQFN 16-lead plastic package.

Ordering Information¹

Part Number	Package
MASW-011030-14040T	500 piece reel
MASW-011030-001SMB	Sample Board

1. Reference Application Note M513 for reel size information.

* Restrictions on Hazardous Substances, European Union Directive 2011/65/EU.

Functional Schematic

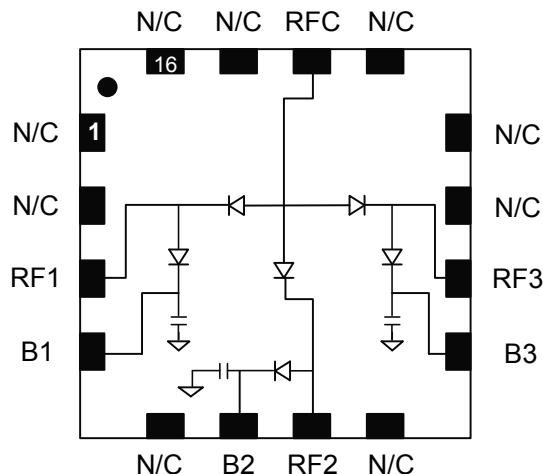

Pin Configuration

Pin	Function	Pin	Function
1	No Connection	9	B3 Bias
2	No Connection	10	RF3 / V3 Bias
3	RF1 / V1 Bias	11	No Connection
4	B1 Bias	12	No Connection
5	No Connection	13	No Connection
6	B2 Bias	14	RFC / V4 Bias
7	RF2 / V2 Bias	15	No Connection
8	No Connection	16	No Connection
		Paddle ²	Ground

2. The exposed pad centered on the package bottom must be connected to RF, DC and thermal ground.

Switch, SP3T 100 Watt Reflective 0.03 - 3.0 GHz

Rev. V1

Electrical Specifications: $T_A = 25^\circ\text{C}$, Bias³ = +5 / -5 V, 50 mA / 100 mA

Parameter	Test Conditions	Units	Min.	Typ.	Max.
Insertion Loss $P_{IN} = 0$ dBm	0.5 GHz 1.0 GHz 2.0 GHz	dB	—	0.15 0.20 0.35	— 0.35 0.50
Isolation $P_{IN} = 0$ dBm	0.5 GHz 1.0 GHz 2.0 GHz	dB	45	50 50 40	—
Input Return Loss	$P_{IN} = 0$ dBm	dB	—	>15	—
CW Input Power	25°C base plate, 2.0 GHz	dBm W	—	52 158	—
CW Input Power	85°C base plate, 2.0 GHz	dBm W	—	50 100	—
P0.1dB	25°C base plate, 2.0 GHz	dBm	—	>52	—
Input IP3	F1 = 2.00 GHz, F2 = 2.01 GHz $P_{IN} = 40$ dBm/Tone, 28 V	dBm	—	62	—
RF Switching Speed	(10-90% RF Voltage) 1 MHz Rep Rate in Modulating Mode	ns	—	800	—

3. See Bias table.

Bias (+5 V / -5 V)⁴

RF State	V1 Bias (V)	V2 Bias (V)	V3 Bias (V)	B1 Bias (V)	B2 Bias (V)	B3 Bias (V)	V4 Bias (V)
RFC – RF1 Low Loss RFC – RF2 Isolation RFC – RF3 Isolation	-5 V @ 100 mA	+5 V @ 50 mA	+5 V @ 50 mA	0 V	0 V	0 V	0 V
RFC – RF2 Low Loss RFC – RF1 Isolation RFC – RF3 Isolation	+5 V @ 50 mA	-5 V @ 100 mA	+5 V @ 50 mA	0 V	0 V	0 V	0 V
RFC – RF3 Low Loss RFC – RF1 Isolation RFC – RF2 Isolation	+5 V @ 50 mA	+5 V @ 50 mA	-5 V @ 100 mA	0 V	0 V	0 V	0 V

4. DC reverse bias of a PIN Diode operating at a high power is dependent on RF frequency, incident power, and VSWR. See Minimum Reverse DC Voltage table for high power operation.

Minimum Reverse DC Voltage⁵

Frequency (MHz)	Minimum Reverse DC Voltage
30	-120 V
100	-119 V
200	-114 V
300	-106 V
500	-90 V
1000	-59 V
1500	-43 V
2000	-33 V

5. Required to maintain low loss under 100 W of incident power with 1.5:1 VSWR

Application Schematic

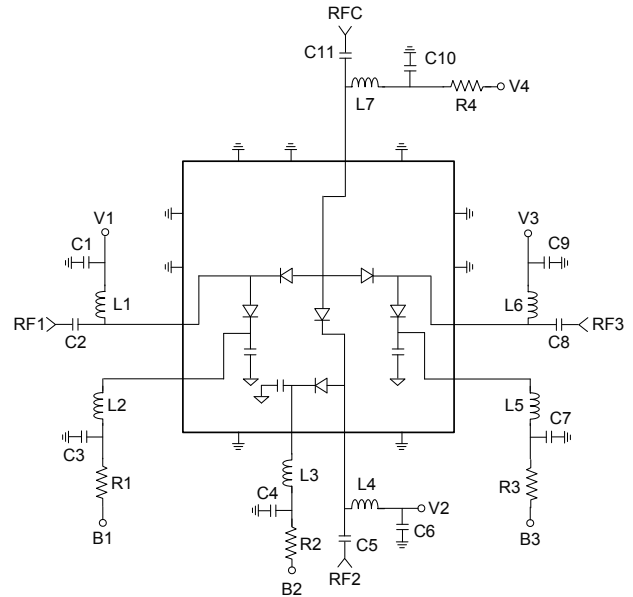

Absolute Maximum Ratings^{6,7}

Parameter	Absolute Maximum
Forward Current	200 mA
Reverse DC Voltage	-150 V
Operating Temperature	-40°C to +85°C
Storage Temperature	-55°C to +150°C
Junction Temperature	+175°C

6. Exceeding any one or combination of these limits may cause permanent damage to this device.
7. MACOM does not recommend sustained operation near these survivability limits.

Off-Chip Component Values

Component	Operating Frequency		Size
	0.03 - 1.0 GHz	0.5 - 3.0 GHz	
C1, C3, C4, C6, C7, C9, C10	0.1 μ F	270 pF	0603
C2, C5, C8, C11	0.1 μ F	27 pF	0603
L1 - L7	3.3 μ H	82 nH	0603
R1 - R3 ⁸	82 Ω	82 Ω	1210
R4 ⁸	39 Ω	39 Ω	1210

8. Resistance values are used for small signal testing under +5 V / -5 V bias conditions.

Typical Performance Curves (using external bias tees):

Insertion Loss

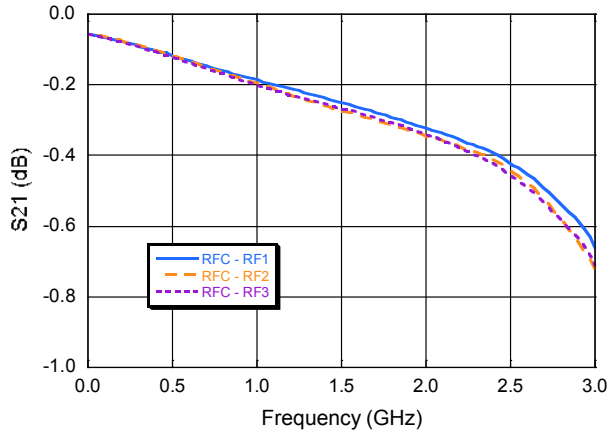

Isolation

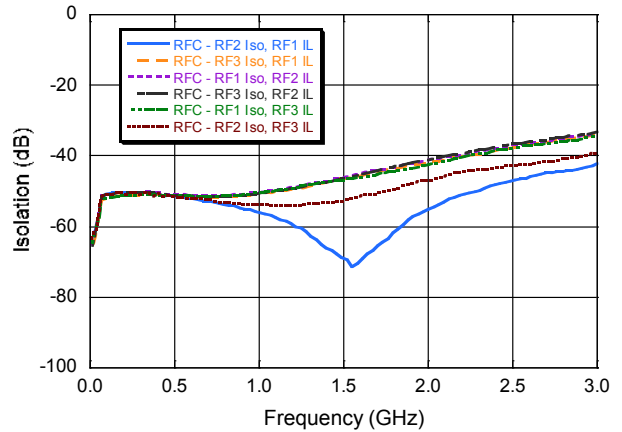

Input Return Loss

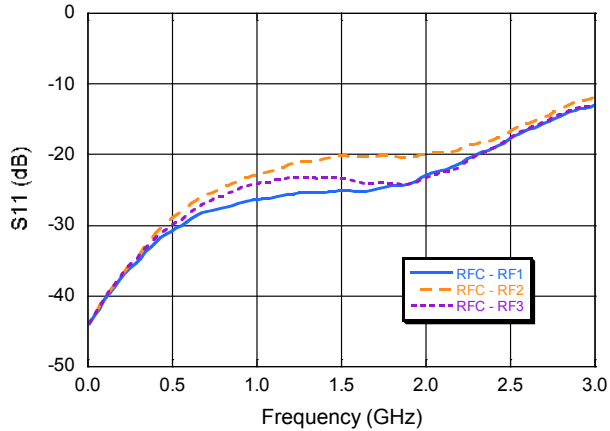

Output Return Loss

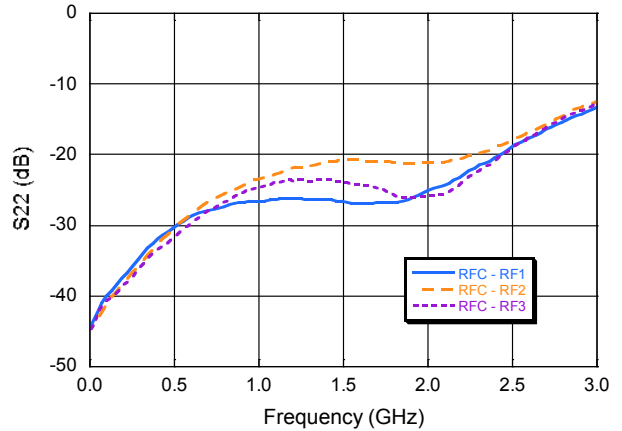

Lead Free 7 mm 16-Lead HQFN †

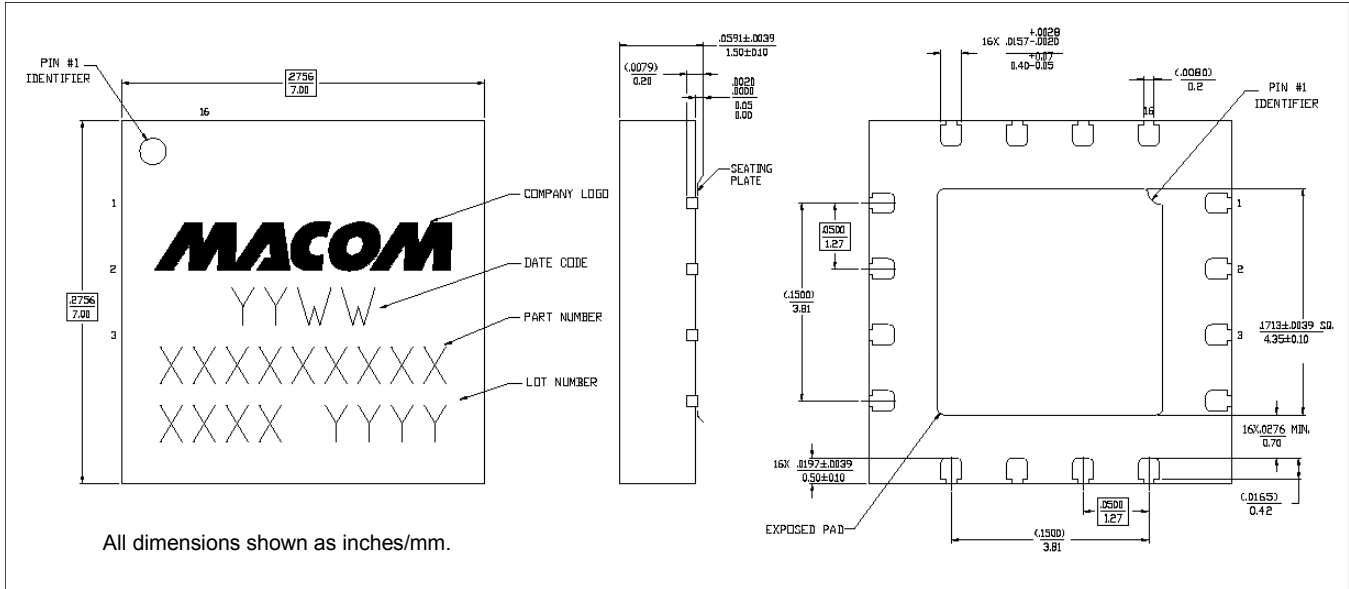

† Reference Application Note S2083 for lead-free solder reflow recommendations.
Meets JEDEC moisture sensitivity level TBD requirements.
Plating is NiPdAuAg.

Handling Procedures

Please observe the following precautions to avoid damage:

Static Sensitivity

These electronic devices are sensitive to electrostatic discharge (ESD) and can be damaged by static electricity. Proper ESD control techniques should be used when handling these Class 1B HBM devices.

Данный компонент на территории Российской Федерации

Вы можете приобрести в компании MosChip.

Для оперативного оформления запроса Вам необходимо перейти по данной ссылке:

<http://moschip.ru/get-element>

Вы можете разместить у нас заказ для любого Вашего проекта, будь то серийное производство или разработка единичного прибора.

В нашем ассортименте представлены ведущие мировые производители активных и пассивных электронных компонентов.

Нашей специализацией является поставка электронной компонентной базы двойного назначения, продукции таких производителей как XILINX, Intel (ex.ALTERA), Vicor, Microchip, Texas Instruments, Analog Devices, Mini-Circuits, Amphenol, Glenair.

Сотрудничество с глобальными дистрибьюторами электронных компонентов, предоставляет возможность заказывать и получать с международных складов практически любой перечень компонентов в оптимальные для Вас сроки.

На всех этапах разработки и производства наши партнеры могут получить квалифицированную поддержку опытных инженеров.

Система менеджмента качества компании отвечает требованиям в соответствии с ГОСТ Р ИСО 9001, ГОСТ РВ 0015-002 и ЭС РД 009

Офис по работе с юридическими лицами:

105318, г.Москва, ул.Щербаковская д.3, офис 1107, 1118, ДЦ «Щербаковский»

Телефон: +7 495 668-12-70 (многоканальный)

Факс: +7 495 668-12-70 (доб.304)

E-mail: info@moschip.ru

Skype отдела продаж:

moschip.ru

moschip.ru_4

moschip.ru_6

moschip.ru_9