

## Digital output magnetic sensor: ultra-low-power, high-performance 3-axis magnetometer

Datasheet - production data

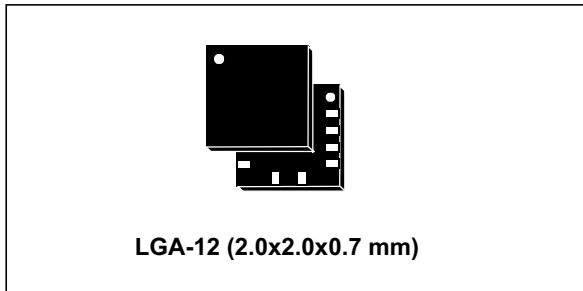

### Features

- 3 magnetic field channels
- $\pm 50$  gauss magnetic dynamic range
- 16-bit data output
- SPI/I<sup>2</sup>C serial interfaces
- Analog supply voltage 1.71 V to 3.6 V
- Selectable power mode/resolution
- Single measurement mode
- Programmable interrupt generator
- Embedded self-test
- Embedded temperature sensor
- ECOPACK<sup>®</sup>, RoHS and “Green” compliant

### Applications

- Tilt-compensated compasses
- Map rotation
- Intelligent power saving for handheld devices
- Gaming and virtual reality input devices

### Description

The LIS2MDL is an ultra-low-power, high-performance 3-axis digital magnetic sensor.

The LIS2MDL has a magnetic field dynamic range of  $\pm 50$  gauss.

The LIS2MDL includes an I<sup>2</sup>C serial bus interface that supports standard, fast mode, fast mode plus, and high-speed (100 kHz, 400 kHz, 1 MHz, and 3.4 MHz) and an SPI serial standard interface.

The device can be configured to generate an interrupt signal for magnetic field detection.

The LIS2MDL is available in a plastic land grid array package (LGA) and is guaranteed to operate over an extended temperature range from -40 °C to +85 °C.

Table 1. Device summary

Part number	Temp. range [°C]	Package	Packaging
LIS2MDL	-40 to +85	LGA-12	Tray
LIS2MDLTR	-40 to +85	LGA-12	Tape and reel

# Contents

<b>1</b>	<b>Block diagram and pin description</b> .....	<b>7</b>
1.1	Block diagram .....	7
1.2	Pin description .....	7
<b>2</b>	<b>Module specifications</b> .....	<b>9</b>
2.1	Sensor characteristics .....	9
2.2	Temperature sensor characteristics .....	10
2.3	Electrical characteristics .....	10
2.4	Communication interface characteristics .....	11
2.4.1	SPI - serial peripheral interface .....	11
2.4.2	I <sup>2</sup> C - inter-IC control interface .....	12
2.5	Absolute maximum ratings .....	14
<b>3</b>	<b>Terminology</b> .....	<b>15</b>
3.1	Sensitivity .....	15
3.2	Zero-gauss level .....	15
3.3	Magnetic dynamic range .....	15
<b>4</b>	<b>Functionality</b> .....	<b>16</b>
4.1	Power modes .....	16
4.2	IC interface .....	18
4.3	Factory calibration .....	18
<b>5</b>	<b>Application hints</b> .....	<b>19</b>
5.1	Soldering information .....	21
5.2	High-current wiring effects .....	21
5.3	Startup sequence .....	21
<b>6</b>	<b>Digital interfaces</b> .....	<b>22</b>
6.1	I <sup>2</sup> C serial interface .....	22
6.1.1	I <sup>2</sup> C operation .....	23
6.2	SPI bus interface .....	25
6.2.1	SPI write .....	25

	6.2.2	SPI read .....	26
<b>7</b>		<b>Register mapping .....</b>	<b>27</b>
<b>8</b>		<b>Register description .....</b>	<b>29</b>
	8.1	OFFSET_X_REG_L (45h) and OFFSET_X_REG_H (46h) .....	29
	8.2	OFFSET_Y_REG_L (47h) and OFFSET_Y_REG_H (48h) .....	29
	8.3	OFFSET_Z_REG_L (49h) and OFFSET_Z_REG_H (4Ah) .....	29
	8.4	WHO_AM_I (4Fh) .....	29
	8.5	CFG_REG_A (60h) .....	30
	8.6	CFG_REG_B (61h) .....	31
	8.7	CFG_REG_C (62h) .....	32
	8.8	INT_CTRL_REG (63h) .....	32
	8.9	INT_SOURCE_REG (64h) .....	33
	8.10	INT_THS_L_REG (65h) .....	33
	8.11	INT_THS_H_REG (66h) .....	33
	8.12	STATUS_REG (67h) .....	34
	8.13	OUTX_L_REG, OUTX_H_REG (68h - 69h) .....	34
	8.14	OUTY_L_REG, OUTY_H_REG (6Ah - 6Bh) .....	36
	8.15	OUTZ_L_REG, OUTZ_H_REG (6Ch - 6Dh) .....	36
	8.16	TEMP_OUT_L_REG (6Eh), TEMP_OUT_H_REG (6Fh) .....	36
<b>9</b>		<b>Package information .....</b>	<b>37</b>
	9.1	LGA-12 package information .....	37
	9.2	LGA-12 packing information .....	38
<b>10</b>		<b>Revision history .....</b>	<b>40</b>

## List of tables

Table 1.	Device summary . . . . .	1
Table 2.	Pin description . . . . .	8
Table 3.	Sensor characteristics . . . . .	9
Table 4.	Temperature sensor characteristics . . . . .	10
Table 5.	Electrical characteristics . . . . .	10
Table 6.	SPI slave timing values . . . . .	11
Table 7.	I <sup>2</sup> C slave timing values (standard and fast mode) . . . . .	12
Table 8.	I <sup>2</sup> C slave timing values (fast mode plus and high speed) . . . . .	12
Table 9.	Absolute maximum ratings . . . . .	14
Table 10.	RMS noise of operating modes . . . . .	16
Table 11.	Current consumption of operating modes . . . . .	16
Table 12.	Operating mode and turn-on time . . . . .	17
Table 13.	Maximum ODR in single measurement mode (HR and LP modes) . . . . .	17
Table 14.	Internal pin status . . . . .	20
Table 15.	Serial interface pin description . . . . .	22
Table 16.	I <sup>2</sup> C terminology . . . . .	22
Table 17.	Transfer when master is writing one byte to slave . . . . .	23
Table 18.	Transfer when master is writing multiple bytes to slave . . . . .	23
Table 19.	Transfer when master is receiving (reading) one byte of data from slave . . . . .	23
Table 20.	Transfer when master is receiving (reading) multiple bytes of data from slave . . . . .	23
Table 21.	SAD + Read/Write patterns . . . . .	24
Table 22.	Register address map . . . . .	27
Table 23.	CFG_REG_A register . . . . .	30
Table 24.	CFG_REG_A register description . . . . .	30
Table 25.	Output data rate configuration . . . . .	30
Table 26.	Mode of operation . . . . .	30
Table 27.	CFG_REG_B_M register . . . . .	31
Table 28.	CFG_REG_B_M register description . . . . .	31
Table 29.	Digital low-pass filter . . . . .	31
Table 30.	CFG_REG_C register . . . . .	32
Table 31.	CFG_REG_C register description . . . . .	32
Table 32.	INT_CTRL_REG register . . . . .	32
Table 33.	INT_CTRL_REG register description . . . . .	32
Table 34.	INT_SOURCE_REG register . . . . .	33
Table 35.	INT_SOURCE_REG register description . . . . .	33
Table 36.	INT_THS_L_REG register . . . . .	33
Table 37.	INT_THS_L_REG register description . . . . .	33
Table 38.	INT_THS_H_REG register . . . . .	33
Table 39.	INT_THS_H_REG register description . . . . .	34
Table 40.	STATUS_REG register . . . . .	34
Table 41.	STATUS_REG register description . . . . .	34
Table 42.	OUTX_L_REG register . . . . .	34
Table 43.	OUTX_H_REG register . . . . .	35
Table 44.	OUTY_L_REG register . . . . .	36
Table 45.	OUTY_H_REG register . . . . .	36
Table 46.	OUTZ_L_REG register . . . . .	36
Table 47.	OUTZ_H_REG register . . . . .	36
Table 48.	Reel dimensions for carrier tape of LGA-12 package . . . . .	39

Table 49. Document revision history. . . . . 40

## List of figures

Figure 1.	Block diagram . . . . .	7
Figure 2.	Pin connections . . . . .	7
Figure 3.	SPI slave timing diagram . . . . .	11
Figure 4.	I <sup>2</sup> C slave timing diagram . . . . .	13
Figure 5.	LIS2MDL electrical connections . . . . .	19
Figure 6.	SPI write protocol . . . . .	25
Figure 7.	Multiple byte SPI write protocol (2-byte example). . . . .	25
Figure 8.	SPI read protocol . . . . .	26
Figure 9.	LGA-12 2.0 x 2.0 x 0.7 mm package outline and mechanical data. . . . .	37
Figure 10.	Carrier tape information for LGA-12 package. . . . .	38
Figure 11.	LGA-12 package orientation in carrier tape . . . . .	38
Figure 12.	Reel information for carrier tape of LGA-12 package . . . . .	39

# 1 Block diagram and pin description

## 1.1 Block diagram

Figure 1. Block diagram

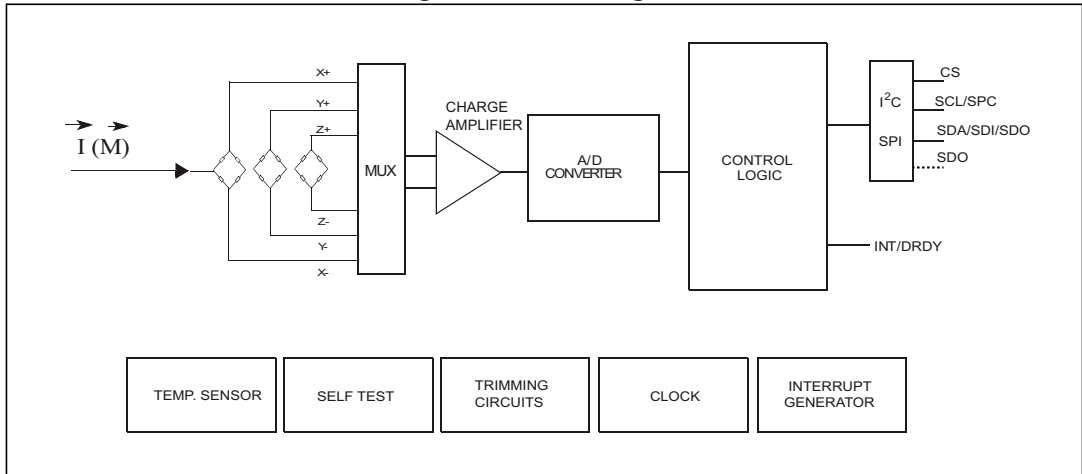

## 1.2 Pin description

Figure 2. Pin connections

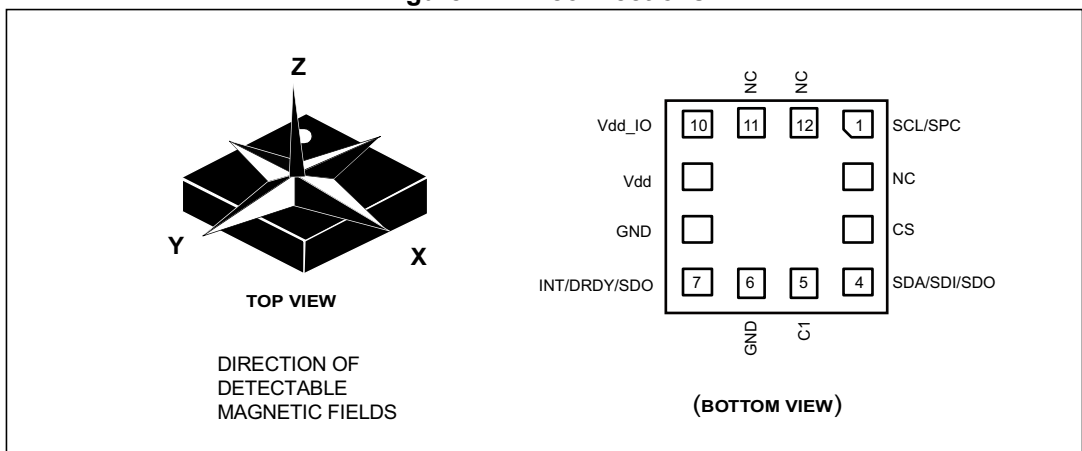

Table 2. Pin description

Pin#	Name	Function
1	SCL SPC	I <sup>2</sup> C serial clock (SCL) SPI serial port clock (SPC)
2	NC	Internally not connected. Can be tied to Vdd, Vdd_IO or GND.
3	CS	I <sup>2</sup> C/SPI mode selection (1: SPI idle mode / I <sup>2</sup> C communication enabled; 0: SPI communication mode / I <sup>2</sup> C disabled)
4	SDA SDI SDO	I <sup>2</sup> C serial data (SDA) SPI serial data input (SDI) 3-wire interface serial data output (SDO)
5	C1	Capacitor connection (C1 = 220 nF)
6	GND	Connected to GND
7	INT/DRDY/SDO	Interrupt/data-ready signal or SDO line for 4-wire SPI connection
8	GND	0 V
9	Vdd	Power supply
10	Vdd_IO	Power supply for I/O pins
11	NC	Internally not connected. Can be tied to Vdd, Vdd_IO or GND.
12	NC	Internally not connected. Can be tied to Vdd, Vdd_IO or GND.



## 2 Module specifications

### 2.1 Sensor characteristics

@ Vdd = 2.5 V, T = 25 °C unless otherwise noted<sup>(a)</sup>.

**Table 3. Sensor characteristics**

Symbol	Parameter	Test conditions	Min.	Typ. <sup>(1)</sup>	Max.	Unit
FS	Magnetic dynamic range			±49.152		gauss
So	Sensitivity <sup>(2)</sup>		-7%	1.5	+7%	mgauss/ LSB
TCSO	Sensitivity change vs. temperature <sup>(3)</sup>			±0.03		%/°C
TyOff	Magnetic sensor offset	With offset cancellation <sup>(4)(5)</sup>	-60		+60	mgauss
TCOff	Magnetic sensor offset change vs. temp. <sup>(4)</sup>	With offset cancellation	-0.3		+0.3	mgauss/ °C
RMS	RMS noise <sup>(6)</sup>	High-resolution mode		3		mgauss (RMS)
ST	Self-test <sup>(7)</sup>		15		500	mgauss
Top	Operating temperature range		-40		+85	°C

1. Typical specifications are not guaranteed.
2. Values after factory calibration test and trimming.
3. Measurements are performed in a uniform temperature setup and they are based on characterization data in a limited number of samples, not measured during final test for production.
4. Based on characterization data on a limited number of samples, not measured during final test for production.
5. Excluding drift due to magnetic shock.
6. With low-pass filter or offset cancellation enabled.
7. "Self-test" is defined as:  $OUTPUT[gauss]_{(Self-test\ enabled)} - OUTPUT[gauss]_{(Self-test\ disabled)}$ .

a. The product is factory calibrated at 2.5 V. The operational power supply range is from 1.71 V to 3.6 V.

## 2.2 Temperature sensor characteristics

@ Vdd = 2.5 V, T = 25 °C unless otherwise noted <sup>(b)</sup>.

**Table 4. Temperature sensor characteristics**

Symbol	Parameter	Test conditions	Min.	Typ. <sup>(1)</sup>	Max.	Unit
TSDr	Temperature sensor output change vs. temp.			8		digit/°C <sup>(2)</sup>
TODR	Temperature refresh rate			ODR <sup>(3)</sup>		Hz
Top	Operating temperature range		-40		+85	°C

1. Typical specifications are not guaranteed.
2. 12-bit resolution.
3. Refer to [Table 25](#).

## 2.3 Electrical characteristics

@ Vdd = 2.5 V, T = 25 °C unless otherwise noted.<sup>(b)</sup>

**Table 5. Electrical characteristics**

Symbol	Parameter	Test conditions	Min.	Typ. <sup>(1)</sup>	Max.	Unit
Vdd	Supply voltage		1.71	2.5	3.6	V
Vdd_IO	Module power supply for I/O		1.71		3.6	V
Idd_HR	Current consumption in high-resolution mode	ODR = 20 Hz		200		µA
Idd_LP	Current consumption in low-power mode	ODR = 20 Hz		50		µA
Idd_PD	Current consumption in power-down			1.5		µA
VIH	Digital high-level input voltage		0.8*Vdd_IO			V
VIL	Digital low-level input voltage				0.2*Vdd_IO	V
VOH	High-level output voltage	IOH = 4 mA	Vdd_IO - 0.2			V
VOL	Low-level output voltage	IOL = 4 mA			0.2	V
T <sub>OP</sub>	Operating temperature range		-40		+85	°C

1. Typical specifications are not guaranteed.

b. The product is factory calibrated at 2.5 V. The operational power supply range is from 1.71 V to 3.6 V.

## 2.4 Communication interface characteristics

### 2.4.1 SPI - serial peripheral interface

Subject to general operating conditions for Vdd and Top.

Table 6. SPI slave timing values

Symbol	Parameter	Value <sup>(1)</sup>		Unit
		Min	Max	
$t_{c(SPC)}$	SPI clock cycle	100		ns
$f_{c(SPC)}$	SPI clock frequency		10	MHz
$t_{su(CS)}$	CS setup time	5		ns
$t_{h(CS)}$	CS hold time	20		
$t_{su(SI)}$	SDI input setup time	5		
$t_{h(SI)}$	SDI input hold time	15		
$t_{v(SO)}$	SDO valid output time		50	
$t_{h(SO)}$	SDO output hold time	5		
$t_{dis(SO)}$	SDO output disable time		50	

Figure 3. SPI slave timing diagram

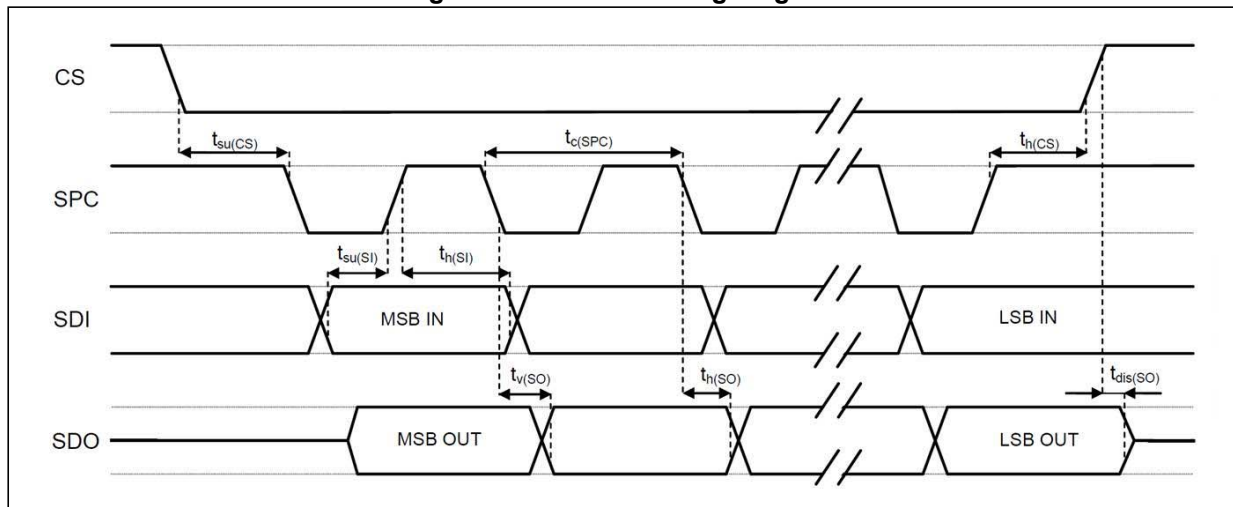

Note: Values are guaranteed at 10 MHz clock frequency for SPI with 3 wires, based on characterization results, not tested in production.  
 Measurement points are done at  $0.2 \cdot V_{dd\_IO}$  and  $0.8 \cdot V_{dd\_IO}$ , for both input and output ports.

### 2.4.2 I<sup>2</sup>C - inter-IC control interface

Subject to general operating conditions for Vdd and Top.

**Table 7. I<sup>2</sup>C slave timing values (standard and fast mode)**

Symbol	Parameter	I <sup>2</sup> C standard mode <sup>(1)</sup>		I <sup>2</sup> C fast mode <sup>(1)</sup>		Unit
		Min	Max	Min	Max	
f <sub>(SCL)</sub>	SCL clock frequency	0	100	0	400	kHz
t <sub>w(SCLL)</sub>	Low period of the SCL clock	4.7		1.3		μs
t <sub>w(SCLH)</sub>	High period of the SCL clock	4.0		0.6		
t <sub>su(SDA)</sub>	Data setup time	250		100		ns
t <sub>h(SDA)</sub>	Data hold time	0	3.45	0	0.9	μs
t <sub>h(ST)</sub>	START condition hold time	4		0.6		
t <sub>su(SR)</sub>	Setup time for a repeated START condition	4.7		0.6		
t <sub>su(SP)</sub>	Setup time for STOP condition	4		0.6		
t <sub>w(SP:SR)</sub>	Bus free time between STOP and START condition	4.7		1.3		

1. Data based on standard I<sup>2</sup>C protocol requirement, not tested in production.

**Table 8. I<sup>2</sup>C slave timing values (fast mode plus and high speed)**

Symbol	Parameter	I <sup>2</sup> C fast mode plus <sup>(1)</sup>		I <sup>2</sup> C high speed <sup>(1)</sup>		Unit
		Min	Max	Min	Max	
f <sub>(SCL)</sub>	SCL clock frequency	0	1	0	3.4	MHz
t <sub>w(SCLL)</sub>	Low period of the SCL clock	0.5		0.16		μs
t <sub>w(SCLH)</sub>	High period of the SCL clock	0.26		0.06		
t <sub>su(SDA)</sub>	Data setup time	50		10		ns
t <sub>h(SDA)</sub>	Data hold time	0		0	0.07	μs
t <sub>h(ST)</sub>	START condition hold time	0.26		0.16		
t <sub>su(SR)</sub>	Setup time for a repeated START condition	0.26		0.16		
t <sub>su(SP)</sub>	Setup time for STOP condition	0.26		0.16		
t <sub>w(SP:SR)</sub>	Bus free time between STOP and START condition	0.5				

1. Data based on standard I<sup>2</sup>C protocol requirement, not tested in production.

Figure 4. I<sup>2</sup>C slave timing diagram

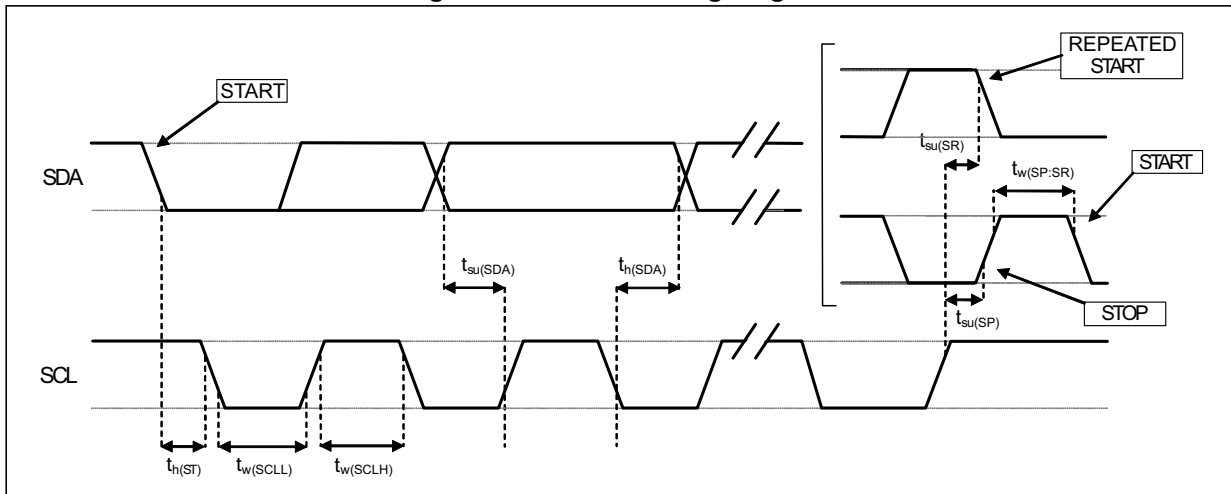

Note: Measurement points are done at  $0.2 \cdot V_{dd\_IO}$  and  $0.8 \cdot V_{dd\_IO}$ , for both ports.

## 2.5 Absolute maximum ratings

Stresses above those listed as “absolute maximum ratings” may cause permanent damage to the device. This is a stress rating only and functional operation of the device under these conditions is not implied. Exposure to maximum rating conditions for extended periods may affect device reliability.

**Table 9. Absolute maximum ratings**

Symbol	Ratings	Maximum value	Unit
V <sub>dd</sub>	Supply voltage	-0.3 to 4.8	V
V <sub>dd_IO</sub>	I/O pins supply voltage	-0.3 to 4.8	V
V <sub>in</sub>	Input voltage on any control pin (CS, SCL/SPC, SDA/SDI/SDO)	-0.3 to V <sub>dd_IO</sub> +0.3	V
M <sub>EF</sub>	Maximum exposed field	10000	gauss
T <sub>OP</sub>	Operating temperature range	-40 to +85	°C
T <sub>STG</sub>	Storage temperature range	-40 to +125	°C
ESD	Electrostatic discharge protection (HBM)	2	kV

*Note:* Supply voltage on any pin should never exceed 4.8 V.



This device is sensitive to mechanical shock, improper handling can cause permanent damage to the part.



This device is sensitive to electrostatic discharge (ESD), improper handling can cause permanent damage to the part.

## **3 Terminology**

### **3.1 Sensitivity**

Sensitivity describes the ratio of the output digital data expressed in LSB units and the applied magnetic field expressed in mG (milligauss). It can be measured, for example, by applying a known magnetic field along one axis and measuring the digital output of the device.

### **3.2 Zero-gauss level**

Zero-gauss level offset (TyOff) describes the deviation of an actual output signal from the ideal output if no magnetic field is present.

### **3.3 Magnetic dynamic range**

The magnetic dynamic range is defined as the magnetic field driven along one sensitive axis, giving the maximum digital output value.

## 4 Functionality

### 4.1 Power modes

The LIS2MDL provides two different power modes: high-resolution and low-power modes.

The tables below summarize the RMS noise values and current consumption in different product configurations.

When the low-pass filter is enabled, the bandwidth is reduced while noise performance is improved without any increase in power consumption.

**Table 10. RMS noise of operating modes**

CFG_REG_B[LPF] or CFG_REG_B[OFF_CANC]	(CFG_REG_A[LP = 0]) high-resolution mode		(CFG_REG_A[LP = 1]) low-power mode	
	BW [Hz]	Noise RMS [mg]	BW [Hz]	Noise RMS [mg]
0 (disable)	ODR/2	4.5	ODR/2	9
1 (enable)	ODR/4	3	ODR/4	6

**Table 11. Current consumption of operating modes**

ODR (Hz)	Current consumption ( $\mu$ A) (CFG_REG_A [LP] = 0) high-resolution CFG_REG_B [OFF_CANC] = 0	Current consumption ( $\mu$ A) (CFG_REG_A [LP] = 1) low-power CFG_REG_B [OFF_CANC] = 0	Current consumption ( $\mu$ A) (CFG_REG_A [LP] = 0) high-resolution CFG_REG_B [OFF_CANC] = 1	Current consumption ( $\mu$ A) (CFG_REG_A [LP] = 1) low-power CFG_REG_B [OFF_CANC] = 1
10	100	25	120	50
20	200	50	235	100
50	475	125	575	235
100	950	250	1130	460



The following table summarizes the turn-on time of the device in the two different power modes with the offset cancellation function enabled or disabled (see [Section : Where Current\\_consumption\\_in\\_power\\_down and Current\\_consumption\\_10Hz can be found, respectively, in Table 5 and Table 11.](#)).

**Table 12. Operating mode and turn-on time**

Operating mode	Turn-on time	
	CFG_REG_A[OFF_CANC = 0]	CFG_REG_A[OFF_CANC = 1]
0 (high-resolution)	9.4 ms	9.4 ms + 1/ODR
1 (low-power)	6.4 ms	6.4 ms + 1/ODR

The LIS2MDL offers single measurement mode in both high-resolution and low-power modes.

Single measurement mode is enabled by writing bits MD[1:0] to '01' in [CFG\\_REG\\_A \(60h\)](#).

In single measurement mode, once the measurement has been performed, the DRDY pin is set to high, data is available in the output register and the LIS2MDL is automatically configured in idle mode by setting the MD[1] bit to '1'.

Single measurement is independent of the programmed ODR but depends on the frequency at which the MD[1:0] bits are written by the microcontroller/application processor.

Maximum ODR frequency achievable in single mode measurement is given in the following table.

**Table 13. Maximum ODR in single measurement mode (HR and LP modes)**

Maximum ODR	Power mode (CFG_REG_A[LP])
100 Hz	High resolution (LP = '0')
150 Hz	Low power (LP = '1')

In single measurement mode, for ODR < 10 Hz, current consumption can be calculated with the following formula:

$$(\text{Current\_consumption\_10Hz} - \text{Current\_consumption\_in\_power\_down}) / (10 \text{ Hz} / \text{ODR}) + \text{Current\_consumption\_in\_power\_down}$$

Where Current\_consumption\_in\_power\_down and Current\_consumption\_10Hz can be found, respectively, in [Table 5](#) and [Table 11](#).

## 4.2 IC interface

The complete measurement chain is composed of a low-noise capacitive amplifier which converts the capacitive unbalancing of the MEMS sensor into an analog voltage using an analog-to-digital converter.

The magnetic data may be accessed through an I<sup>2</sup>C/SPI interface thus making the device particularly suitable for direct interfacing with a microcontroller.

The LIS2MDL features a data-ready signal which indicates when new sets of measured magnetic data are available, thus simplifying data synchronization in the digital system that uses the device.

## 4.3 Factory calibration

The IC interface is factory calibrated for sensitivity ( $S_0$ ) and Zero-*gauss* level (TyOff).

The trim values are stored inside the device in nonvolatile memory. Anytime the device is turned on, the trim parameters are downloaded into the registers to be used during active operation. This allows using the device without further calibration.

## 5 Application hints

Figure 5. LIS2MDL electrical connections

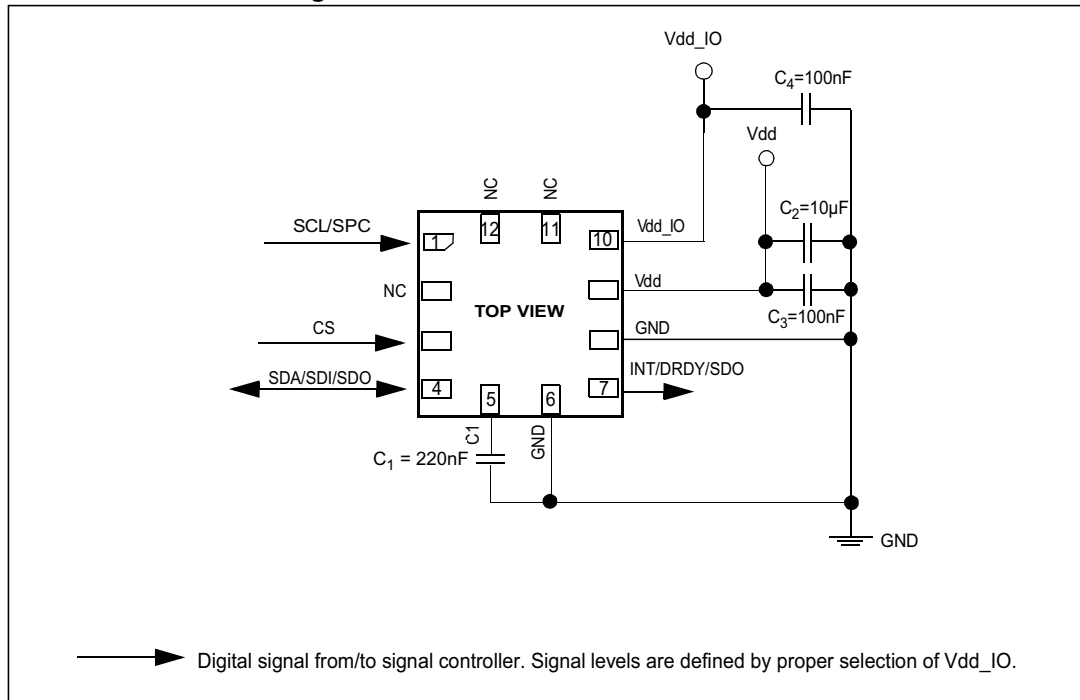

The device core is supplied through the Vdd line while the I/O pads are supplied through the Vdd\_IO line. Power supply decoupling capacitors (100 nF ceramic, 10 µF aluminum) should be placed as near as possible to pin 9 of the device (common design practice).

It is possible to remove Vdd, maintaining Vdd\_IO, without blocking the communication bus, in this condition the measurement chain is powered off.

The following recommendations apply to capacitor C1:

- It must be connected as close as possible to pins 5 and 6 since very high current pulses flow from C1 to pin 5 and 6. This avoids problems caused by inductive effects due to the length of the copper strips.
- It is highly recommended to use low ESR (max 200 mOhm)

The functionality of the device and the measured acceleration data are selectable and accessible through the I<sup>2</sup>C or SPI interfaces. When using the I<sup>2</sup>C, CS must be tied high (i.e. connected to Vdd\_IO).

The functions, the threshold and the timing of the interrupt pin (INT) can be completely programmed by the user through the I<sup>2</sup>C/SPI interface.

Table 14. Internal pin status

Pin#	Name	Function	Pin status
1	SCL SPC	I <sup>2</sup> C serial clock (SCL) SPI serial port clock (SPC)	Default: input without pull-up
2	NC		Internally not connected
3	CS	I <sup>2</sup> C/SPI mode selection (1: SPI idle mode / I <sup>2</sup> C communication enabled; 0: SPI communication mode / I <sup>2</sup> C disabled)	Default: input without pull-up
4	SDA SDI SDO	I <sup>2</sup> C serial data (SDA) SPI serial data input (SDI) 3-wire interface serial data output (SDO)	Default: (SDA) input without pull-up
5	C1	Capacitor connection (C1 = 220 nF)	External capacitor, voltage forced by the device
6	GND	0 V	
7	INT/DRDY/SDO	Interrupt/data-ready signal or SDO for 4-wire SPI interface	Default: output high impedance
8	GND	0 V	
9	Vdd	Power supply	
10	Vdd_IO	Power supply for I/O pins	
11	NC		Internally not connected
12	NC		Internally not connected

**Note:** In order to program INT/DRDY as a push-pull output, write the INT\_on\_PIN bit or DRDY\_on\_PIN bit to '1' in CFG\_REG\_C (62h).

Please refer to AN5069 for more information (magnetometer offset cancellation, magnetometer hard-iron compensation, interrupt generation, self-test procedure).

## 5.1 Soldering information

The LGA package is compliant with the ECOPACK<sup>®</sup>, RoHS and “Green” standards. It is qualified for soldering heat resistance according to JEDEC J-STD-020.

Land pattern and soldering recommendations are available at [www.st.com](http://www.st.com).

## 5.2 High-current wiring effects

High current in wiring and printed circuit traces can be culprits in causing errors in magnetic field measurements for compassing.

Conductor-generated magnetic fields will add to the Earth’s magnetic field, leading to errors in compass heading computation.

Keep currents higher than 10 mA a few millimeters away from the sensor IC.

## 5.3 Startup sequence

The following general-purpose sequence can be used to configure the device:

1. Write CFG\_REG\_A = 80h // Enable temperature compensation  
//Mag = 10 Hz (high-resolution and continuous mode)
2. Write CFG\_REG\_C = 01h // Mag data-ready interrupt enable

## 6 Digital interfaces

The registers embedded inside the LIS2MDL may be accessed through both the I<sup>2</sup>C and 3W SPI serial interfaces.

The serial interfaces are mapped to the same pads. To select/exploit the I<sup>2</sup>C interface, the CS line must be tied high (i.e. connected to Vdd\_IO).

**Table 15. Serial interface pin description**

Pin name	Pin description
CS	SPI enable I <sup>2</sup> C/SPI mode selection (1: SPI idle mode / I <sup>2</sup> C communication enabled; 0: SPI communication mode / I <sup>2</sup> C disabled)
SCL	I <sup>2</sup> C serial clock (SCL)
SPC	SPI serial port clock (SPC)
SDA	I <sup>2</sup> C serial data (SDA)
SDI	SPI serial data input (SDI)
SDO	3W SPI interface serial data output (SDO)
SDO	4W SPI interface serial data output (SDO)

### 6.1 I<sup>2</sup>C serial interface

The LIS2MDL I<sup>2</sup>C is a bus slave. The I<sup>2</sup>C is employed to write data into registers whose content can also be read back.

The relevant I<sup>2</sup>C terminology is given in the table below.

**Table 16. I<sup>2</sup>C terminology**

Term	Description
Transmitter	The device which sends data to the bus
Receiver	The device which receives data from the bus
Master	The device which initiates a transfer, generates clock signals and terminates a transfer
Slave	The device addressed by the master

There are two signals associated with the I<sup>2</sup>C bus: the serial clock line (SCL) and the serial data line (SDA). The latter is a bidirectional line used for sending and receiving the data to/from the interface. Both the lines must be connected to Vdd\_IO through an external pull-up resistor. When the bus is free, both the lines are high.

The I<sup>2</sup>C interface is compliant with standard mode (100 kHz), fast mode (400 kHz), fast mode plus (1 MHz) and high-speed mode (3.4 MHz).

### 6.1.1 I<sup>2</sup>C operation

The transaction on the bus is started through a START (ST) signal. A START condition is defined as a high-to-low transition on the data line while the SCL line is held high. After this has been transmitted by the master, the bus is considered busy. The next byte of data transmitted after the start condition contains the address of the slave in the first 7 bits and the eighth bit tells whether the master is receiving data from the slave or transmitting data to the slave. When an address is sent, each device in the system compares the first seven bits after a start condition with its address. If they match, the device considers itself addressed by the master.

Data transfer with acknowledge is mandatory. The transmitter must release the SDA line during the acknowledge pulse. The receiver must then pull the data line LOW so that it remains stable low during the high period of the acknowledge clock pulse. A receiver which has been addressed is obliged to generate an acknowledge after each byte of data received.

The I<sup>2</sup>C embedded inside the LIS2MDL behaves like a slave device and the following protocol must be adhered to. After the start condition (ST) a slave address is sent, once a slave acknowledge (SAK) has been returned, an 8-bit sub-address (SUB) is transmitted: the 7 LSb represent the actual register address while the MSB enables address auto increment. If the MSb of the SUB field is '1', the SUB (register address) is automatically increased to allow multiple data read/writes.

The slave address is completed with a Read/Write bit. If the bit was '1' (Read), a repeated START (SR) condition must be issued after the two sub-address bytes; if the bit is '0' (Write) the master will transmit to the slave with direction unchanged. [Table 21](#) explains how the SAD+read/write bit pattern is composed, listing all the possible configurations.

**Table 17. Transfer when master is writing one byte to slave**

Master	ST	SAD + W		SUB		DATA		SP
Slave			SAK		SAK		SAK	

**Table 18. Transfer when master is writing multiple bytes to slave**

Master	ST	SAD + W		SUB		DATA		DATA		SP
Slave			SAK		SAK		SAK		SAK	

**Table 19. Transfer when master is receiving (reading) one byte of data from slave**

Master	ST	SAD + W		SUB		SR	SAD + R			NMAK	SP
Slave			SAK		SAK			SAK	DATA		

**Table 20. Transfer when master is receiving (reading) multiple bytes of data from slave**

Master	ST	SAD+W		SUB		SR	SAD+R			MAK		MAK		NMAK	SP
Slave			SAK		SAK			SAK	DATA		DATA		DATA		

Data are transmitted in byte format (DATA). Each data transfer contains 8 bits. The number of bytes transferred per transfer is unlimited. Data is transferred with the Most Significant bit



(MSb) first. If a receiver can't receive another complete byte of data until it has performed some other function, it can hold the clock line SCL low to force the transmitter into a wait state. Data transfer only continues when the receiver is ready for another byte and releases the data line. If a slave receiver doesn't acknowledge the slave address (i.e. it is not able to receive because it is performing some real-time function) the data line must be left high by the slave. The master can then abort the transfer. A low-to-high transition on the SDA line while the SCL line is high is defined as a STOP condition. Each data transfer must be terminated by the generation of a STOP (SP) condition.

In the presented communication format MAK is Master acknowledge and NMAK is No Master Acknowledge.

**Default address:**

The slave address is 0011110b.

The slave address is completed with a Read/Write bit. If the bit was '1' (Read), a repeated START (SR) condition must be issued after the sub-address byte. If the bit is '0' (Write) the master will transmit to the slave with direction unchanged. [Table 21](#) explains how the SAD+Read/Write bit patterns are composed, listing all the possible configurations.

**Table 21. SAD + Read/Write patterns**

Command	SAD[6:0]	R/W	SAD + R/W
Read	0011110	1	00111101 (3Dh)
Write	0011110	0	00111100 (3Ch)



## 6.2 SPI bus interface

The LIS2MDL SPI is a bus slave. The SPI allows writing and reading the registers of the device.

The default serial interface interacts with the application using 3 wires: **CS**, **SPC**, **SDI/O**.

The 4-wire SPI interface mode can be activated by writing bit 2 of *CFG\_REG\_C (62h)* to 1. Of course, doing this disables the interrupt and data-ready signaling capability of the device.

### 6.2.1 SPI write

Figure 6. SPI write protocol

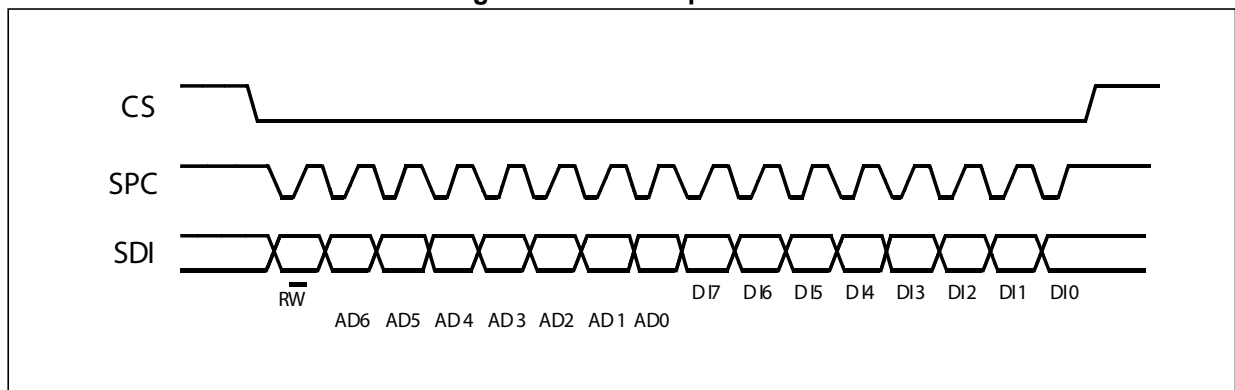

The SPI write command is performed with 16 clock pulses. The multiple byte write command is performed by adding blocks of 8 clock pulses to the previous one.

**bit 0:** WRITE bit. The value is 0.

**bit 1-7:** address AD(6:0). This is the address field of the indexed register.

**bit 8-15:** data DI(7:0) (write mode). This is the data that is written inside the device (MSb first).

**bit 16-...** : data DI(...-8). Further data in multiple byte writes.

Figure 7. Multiple byte SPI write protocol (2-byte example)

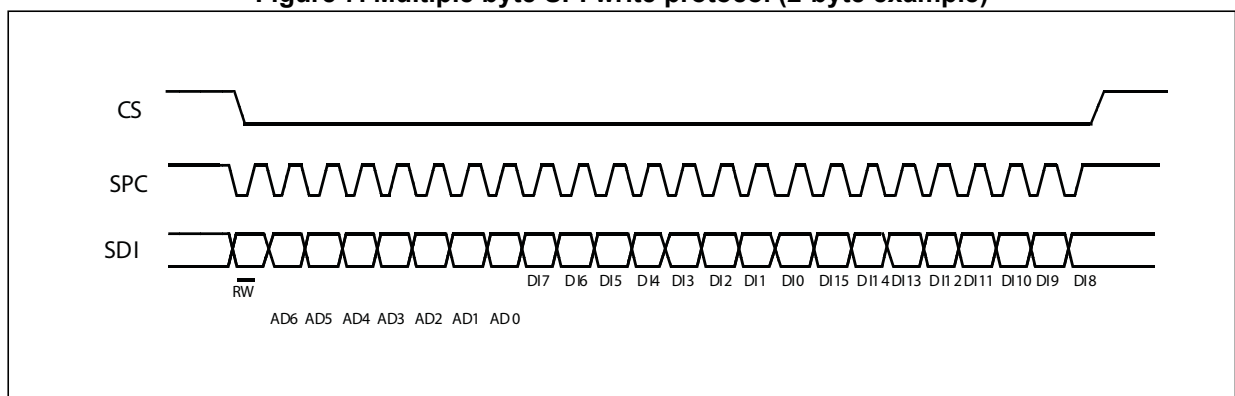

6.2.2 SPI read

Figure 8. SPI read protocol

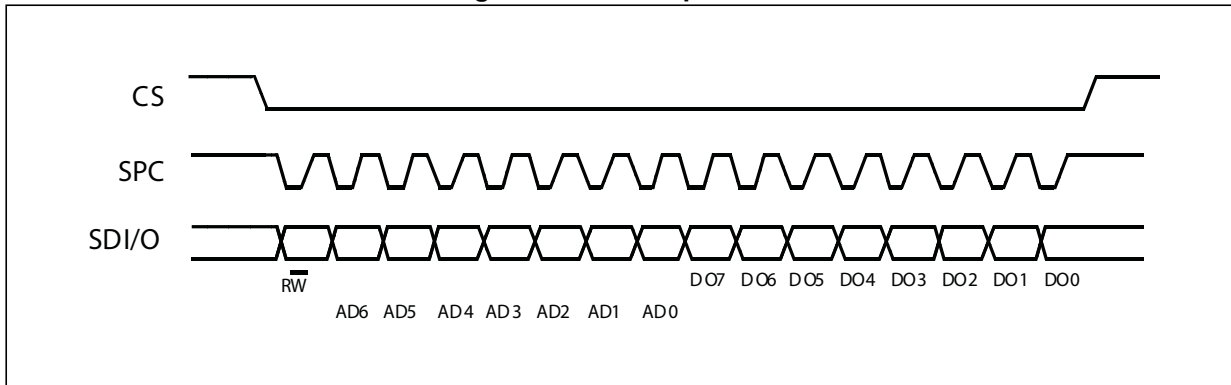

The SPI read command is performed with 16 clock pulses. A multiple read is performed by adding blocks of 8 clock pulses to the previous one. The reading address is automatically incremented.

**bit 0:** WRITE bit. The value is 1.

**bit 1-7:** address AD(6:0). This is the address field of the indexed register.

**bit 8-15:** data DO(7:0) (read mode). This is the data that is read from the device (MSb first).

A multiple read command is available in 3-wire mode.

## 7 Register mapping

The table given below provides a list of the 8-bit registers embedded in the device and the corresponding addresses.

**Table 22. Register address map**

Name	Type <sup>(1)</sup>	Register address		Default	Comment
		Hex	Binary		
Reserved		00 - 44			Reserved
OFFSET_X_REG_L	R/W	45	01000101	00000000	Hard-iron registers
OFFSET_X_REG_H	R/W	46	01000110	00000000	
OFFSET_Y_REG_L	R/W	47	01000111	00000000	
OFFSET_Y_REG_H	R/W	48	01001000	00000000	
OFFSET_Z_REG_L	R/W	49	01001001	00000000	
OFFSET_Z_REG_H	R/W	4A	01001010	00000000	
RESERVED		4B-4C			Reserved
WHO_AM_I	R	4F	01001111	01000000	
RESERVED		50-5F			Reserved
CFG_REG_A	R/W	60	01100000	00000011	Configuration registers
CFG_REG_B	R/W	61	01100001	00000000	
CFG_REG_C	R/W	62	01100010	00000000	
INT_CTRL_REG	R/W	63	01100011	11100000	Interrupt configuration registers
INT_SOURCE_REG	R	64	01100100		
INT_THS_L_REG	R/W	65	01100101	00000000	
INT_THS_H_REG	R/W	66	01100110	00000000	
STATUS_REG	R	67	01100111		
OUTX_L_REG	R	68	01101000	output	Output registers
OUTX_H_REG	R	69	01101001	output	
OUTY_L_REG	R	6A	01101010	output	
OUTY_H_REG	R	6B	01101010	output	
OUTZ_L_REG	R	6C	01101100	output	
OUTZ_H_REG	R	6D	01101101	output	
TEMP_OUT_L_REG	R	6E	01101110	output	Temperature sensor registers
TEMP_OUT_H_REG	R	6F	01101111	output	

1. R = read-only register, R/W = readable/writable register

Registers marked as *Reserved* must not be changed. Writing to those registers may cause permanent damage to the device.

The content of the registers that are loaded at boot should not be changed. They contain the factory calibration values. Their content is automatically restored when the device is powered up.

## 8 Register description

### 8.1 OFFSET\_X\_REG\_L (45h) and OFFSET\_X\_REG\_H (46h)

These registers comprise a 16-bit register and represent X hard-iron offset in order to compensate environmental effects (data in two's complement). These values act on the magnetic output data value in order to delete the environmental offset.

### 8.2 OFFSET\_Y\_REG\_L (47h) and OFFSET\_Y\_REG\_H (48h)

These registers comprise a 16-bit register and represent Y hard-iron offset in order to compensate environmental effects (data in two's complement). These values act on the magnetic output data value in order to delete the environmental offset.

### 8.3 OFFSET\_Z\_REG\_L (49h) and OFFSET\_Z\_REG\_H (4Ah)

These registers comprise a 16-bit register and represent Z hard-iron offset in order to compensate environmental effects (data in two's complement). These values act on the magnetic output data value in order to delete the environmental offset.

### 8.4 WHO\_AM\_I (4Fh)

The identification register is used to identify the device.

0	1	0	0	0	0	0	0
---	---	---	---	---	---	---	---

## 8.5 CFG\_REG\_A (60h)

The configuration register is used to configure the output data rate and the measurement configuration.

**Table 23. CFG\_REG\_A register**

COMP_TEMP_EN	REBOOT	SOFT_RST	LP	ODR1	ODR0	MD1	MD0
--------------	--------	----------	----	------	------	-----	-----

**Table 24. CFG\_REG\_A register description**

COMP_TEMP_EN <sup>(1)</sup>	Enables the magnetometer temperature compensation. Default value: 0 (0: temperature compensation disabled; 1: temperature compensation enabled)
REBOOT	Reboot magnetometer memory content. Default value: 0 (0: normal mode; 1: reboot memory content)
SOFT_RST	When this bit is set, the configuration registers and user registers are reset. Flash registers keep their values. Default value: 0
LP	Enables low-power mode. Default value: 0 0: high-resolution mode 1: low-power mode enabled
ODR[1:0]	Output data rate configuration (see <a href="#">Table 25: Output data rate configuration</a> ) Default value: 00
MD[1:0]	These bits select the mode of operation of the device (see <a href="#">Table 26: Mode of operation</a> ). Default value: 11

1. For proper operation, this bit must be set to '1'.

**Table 25. Output data rate configuration**

ODR1	ODR0	ODR (Hz)
0	0	10 (default)
0	1	20
1	0	50
1	1	100

**Table 26. Mode of operation**

MD1	MD0	Mode
0	0	Continuous mode. In continuous mode the device continuously performs measurements and places the result in the data register. The data-ready signal is generated when a new data set is ready to be read. This signal can be available on the external pin by setting the DRDY_on_PIN bit in <a href="#">CFG_REG_C (62h)</a> .
0	1	Single mode. When single mode is selected, the device performs a single measurement, sets DRDY high and returns to idle mode. Mode register returns to idle mode bit values.
1	0	Idle mode. Device is placed in idle mode. I <sup>2</sup> C and SPI active.
1	1	Idle mode. Device is placed in idle mode. I <sup>2</sup> C and SPI active (default).

## 8.6 CFG\_REG\_B (61h)

**Table 27. CFG\_REG\_B\_M register**

0	0	0	OFF_CANC_ONE_SHOT	INT_on_DataOFF	Set_FREQ	OFF_CANC	LPF
---	---	---	-------------------	----------------	----------	----------	-----

**Table 28. CFG\_REG\_B\_M register description**

OFF_CANC_ONE_SHOT	Enables offset cancellation in single measurement mode. The OFF_CANC bit must be set to 1 when enabling offset cancellation in single measurement mode. Default value: 0 (0: offset cancellation in single measurement mode disabled; 1: offset cancellation in single measurement mode enabled)
INT_on_DataOFF	If '1', the interrupt block recognition checks data after the hard-iron correction to discover the interrupt. Default value: 0
Set_FREQ	Selects the frequency of the set pulse. Default value: 0 (0: set pulse is released every 63 ODR; 1: set pulse is released only at power-on after PD condition)
OFF_CANC	Enables offset cancellation. Default value: 0 (0: offset cancellation disabled; 1: offset cancellation enabled)
LPF	Enables low-pass filter (see <a href="#">Table 29</a> ). Default value: 0 (0: digital filter disabled; 1: digital filter enabled)

**Table 29. Digital low-pass filter**

CFG_REG_B[LPF]	BW [Hz]
0 (disable)	ODR/2
1 (enable)	ODR/4

## 8.7 CFG\_REG\_C (62h)

**Table 30. CFG\_REG\_C register**

0	INT_on_PIN	I2C_DIS	BDU	BLE	4WSPI	Self_test	DRDY_on_PIN
---	------------	---------	-----	-----	-------	-----------	-------------

**Table 31. CFG\_REG\_C register description**

INT_on_PIN	If '1', the INTERRUPT signal (INT bit in <i>INT_SOURCE_REG (64h)</i> ) is driven on the INT/DRDY pin. The INT/DRDY pin is configured in push-pull output mode. Default value: 0
I2C_DIS	If '1', the I <sup>2</sup> C interface is inhibited. Only the SPI interface can be used.
BDU	If enabled, reading of incorrect data is avoided when the user reads asynchronously. In fact if the read request arrives during an update of the output data, a latch is possible, reading incoherent high and low parts of the same register. Only one part is updated and the other one remains old.
BLE	If '1', an inversion of the low and high parts of the data occurs.
4WSPI	Set to '1' to enable SDO line on pin 7.
Self_test	If '1', the self-test is enabled.
DRDY_on_PIN	If '1', the data-ready signal (Zyxda bit in <i>STATUS_REG (67h)</i> ) is driven on the INT/DRDY pin. The INT/DRDY pin is configured in push-pull output mode. Default value: 0

## 8.8 INT\_CTRL\_REG (63h)

The interrupt control register is used to enable and to configure the interrupt recognition.

**Table 32. INT\_CTRL\_REG register**

XIEN	YIEN	ZIEN	0 <sup>(1)</sup>	0 <sup>(1)</sup>	IEA	IEL	IEN
------	------	------	------------------	------------------	-----	-----	-----

1. This bit must be set to '0' for the correct operation of the device.

**Table 33. INT\_CTRL\_REG register description**

XIEN	Enables the interrupt detection for the X-axis. Default value: 1 (1: enabled; 0: disabled)
YIEN	Enables the interrupt detection for the Y-axis. Default value: 1 (1: enabled; 0: disabled)
ZIEN	Enables the interrupt detection for the Z-axis. Default value: 1 (1: enabled; 0: disabled)
IEA	Controls the polarity of the INT bit ( <i>INT_SOURCE_REG (64h)</i> ) when an interrupt occurs. Default: 0 If IEA = 0, then INT = 0 signals an interrupt If IEA = 1, then INT = 1 signals an interrupt



**Table 33. INT\_CTRL\_REG register description (continued)**

IEL	Controls whether the INT bit ( <a href="#">INT_SOURCE_REG (64h)</a> ) is latched or pulsed. Default: 0 If IEL = 0, then INT is pulsed. If IEL = 1, then INT is latched. Once latched, INT remains in the same state until <a href="#">INT_SOURCE_REG (64h)</a> is read.
IEN	Interrupt enable. When set, enables the interrupt generation. The INT bit is in <a href="#">INT_SOURCE_REG (64h)</a> . Default: 0

## 8.9 INT\_SOURCE\_REG (64h)

When interrupt latched is selected, reading this register resets all the bits in this register.

**Table 34. INT\_SOURCE\_REG register**

P_TH_S_X	P_TH_S_Y	P_TH_S_Z	N_TH_S_X	N_TH_S_Y	N_TH_S_Z	MROI	INT
----------	----------	----------	----------	----------	----------	------	-----

**Table 35. INT\_SOURCE\_REG register description**

P_TH_S_X	X-axis value exceeds the threshold positive side
P_TH_S_Y	Y-axis value exceeds the threshold positive side
P_TH_S_Z	Z-axis value exceeds the threshold positive side
N_TH_S_X	X-axis value exceeds the threshold negative side
N_TH_S_Y	Y-axis value exceeds the threshold negative side
N_TH_S_Z	Z-axis value exceeds the threshold negative side
MROI	MROI flag generation is always enabled. This flag is reset by reading <a href="#">INT_SOURCE_REG (64h)</a> .
INT	This bit signals when the interrupt event occurs.

## 8.10 INT\_THS\_L\_REG (65h)

This register contains the least significant bits of the threshold value chosen for the interrupt.

**Table 36. INT\_THS\_L\_REG register**

TH7	TH6	TH5	TH4	TH3	TH2	TH1	TH0
-----	-----	-----	-----	-----	-----	-----	-----

**Table 37. INT\_THS\_L\_REG register description**

TH[7:0]	Threshold value for the interrupt.
---------	------------------------------------

## 8.11 INT\_THS\_H\_REG (66h)

This register contains the most significant bits of the threshold value chosen for the interrupt.

**Table 38. INT\_THS\_H\_REG register**

TH15	TH14	TH13	TH12	TH11	TH10	TH9	TH8
------	------	------	------	------	------	-----	-----

**Table 39. INT\_THS\_H\_REG register description**

TH[15:8]	Threshold value for the interrupt.
----------	------------------------------------

These registers set the threshold value for the output to generate the interrupt (INT bit in [INT\\_SOURCE\\_REG \(64h\)](#)). This threshold is common to all three (axes) output values and is unsigned unipolar. The threshold value is correlated to the current gain and it is unsigned because the threshold is considered as an absolute value, but crossing the threshold is detected for both positive and negative sides.

## 8.12 STATUS\_REG (67h)

The status register is an 8-bit read-only register. This register is used to indicate device status.

**Table 40. STATUS\_REG register**

Zyxor	zor	yor	xor	Zyxda	zda	yda	xda
-------	-----	-----	-----	-------	-----	-----	-----

**Table 41. STATUS\_REG register description**

Zyxor	X-, Y- and Z-axis data overrun. Default value: 0 (0: no overrun has occurred; 1: a new set of data has overwritten the previous set).
zor	Z-axis data overrun. Default value: 0 (0: no overrun has occurred; 1: new data for the Z-axis has overwritten the previous data).
yor	Y-axis data overrun. Default value: 0 (0: no overrun has occurred; 1: new data for the Y-axis has overwritten the previous data).
xor	X-axis data overrun. Default value: 0 (0: no overrun has occurred; 1: new data for the X-axis has overwritten the previous data).
Zyxda	X-, Y- and Z-axis new data available. Default value: 0 (0: a new set of data is not yet available; 1: a new set of data is available).
zda	Z-axis new data available. Default value: 0 (0: a new data for the Z-axis is not yet available; 1: a new data for the Z-axis is available)
yda	Y-axis new data available. Default value: 0 (0: a new data for the Y-axis is not yet available; 1: a new data for the Y-axis is available)
xda	X-axis new data available. Default value: 0 (0: a new data for the X-axis is not yet available; 1: a new data for the X-axis is available)

## 8.13 OUTX\_L\_REG, OUTX\_H\_REG (68h - 69h)

The data output X registers are two 8-bit registers, data output X MSB register (69h) and output X LSB register (68h).

The output data represents the raw magnetic data only if OFFSET\_X\_REG is equal to zero, otherwise hard-iron calibration is included.

**Table 42. OUTX\_L\_REG register**

0	0	0	0	0	0	0	0
---	---	---	---	---	---	---	---

**Table 43. OUTX\_H\_REG register**

0	0	0	0	0	0	0	0
---	---	---	---	---	---	---	---

The value of the magnetic field is expressed in two's complement. This register contains the X component of the magnetic data.

### 8.14 OUTY\_L\_REG, OUTY\_H\_REG (6Ah - 6Bh)

The data output Y registers are two 8-bit registers, data output Y MSB register (6Bh) and output Y LSB register (6Ah).

The output data represents the raw magnetic data only if OFFSET\_Y\_REG is equal to zero, otherwise hard-iron calibration is included.

**Table 44. OUTY\_L\_REG register**

0	0	0	0	0	0	0	0
---	---	---	---	---	---	---	---

**Table 45. OUTY\_H\_REG register**

0	0	0	0	0	0	0	0
---	---	---	---	---	---	---	---

The value of the magnetic field is expressed in two's complement. This register contains the Y component of the magnetic data.

### 8.15 OUTZ\_L\_REG, OUTZ\_H\_REG (6Ch - 6Dh)

The data output Z registers are two 8-bit registers, data output Z MSB register (6Dh) and output Z LSB register (6Ch).

The output data represents the raw magnetic data only if OFFSET\_Z\_REG is equal to zero, otherwise hard-iron calibration is included.

**Table 46. OUTZ\_L\_REG register**

0	0	0	0	0	0	0	0
---	---	---	---	---	---	---	---

**Table 47. OUTZ\_H\_REG register**

0	0	0	0	0	0	0	0
---	---	---	---	---	---	---	---

The value of the magnetic field is expressed in two's complement. This register contains the Z component of the magnetic data.

### 8.16 TEMP\_OUT\_L\_REG (6Eh), TEMP\_OUT\_H\_REG (6Fh)

Temperature sensor data.

These registers contain temperature values from the internal temperature sensor. The output value is expressed as a signed 16-bit byte in 2's complement. The four most significant bits contain a copy of the sign bit.

The nominal sensitivity is 8 LSB/°C.

# 9 Package information

In order to meet environmental requirements, ST offers these devices in different grades of ECOPACK® packages, depending on their level of environmental compliance. ECOPACK® specifications, grade definitions and product status are available at: [www.st.com](http://www.st.com). ECOPACK is an ST trademark.

## 9.1 LGA-12 package information

Figure 9. LGA-12 2.0 x 2.0 x 0.7 mm package outline and mechanical data

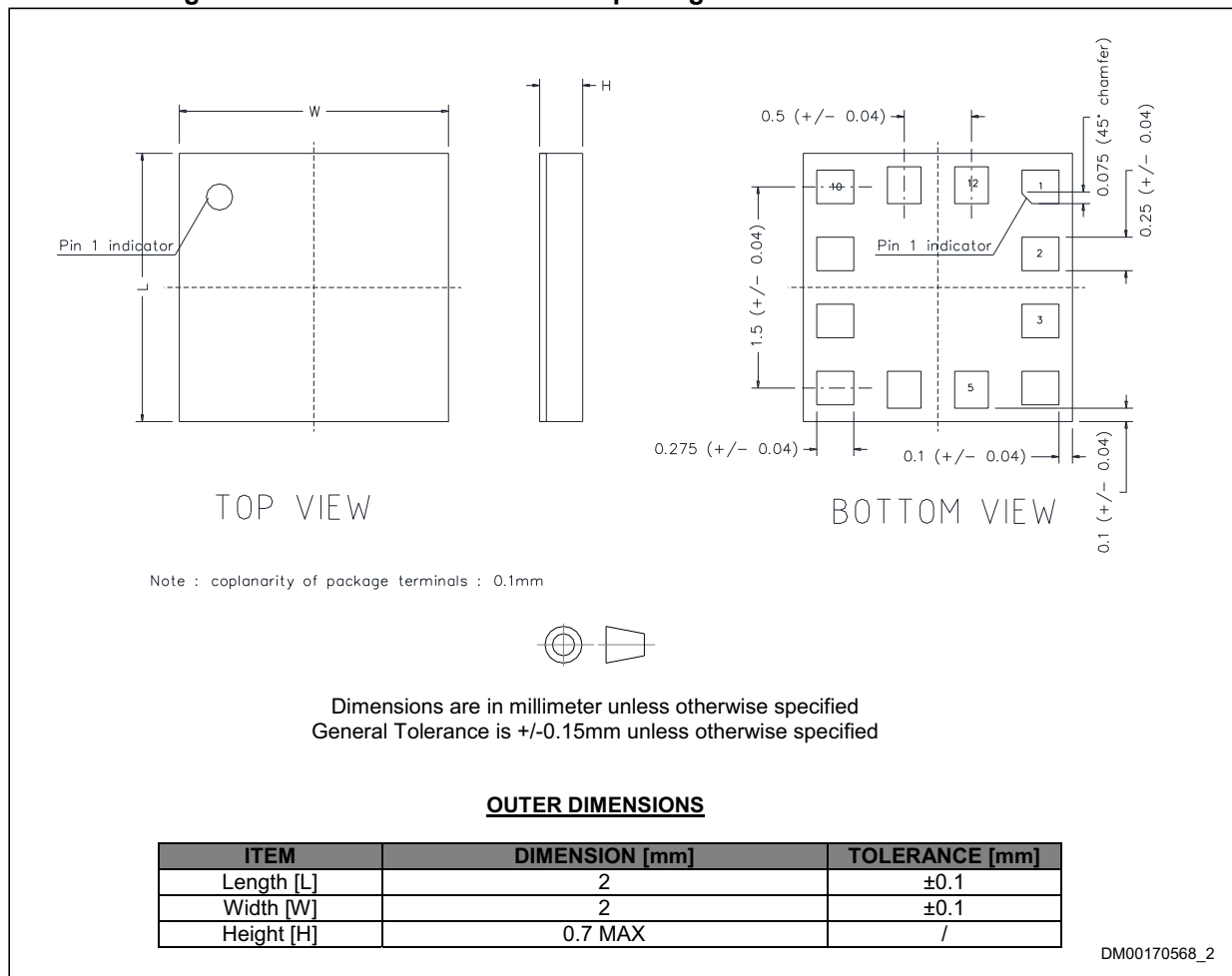

## 9.2 LGA-12 packing information

Figure 10. Carrier tape information for LGA-12 package

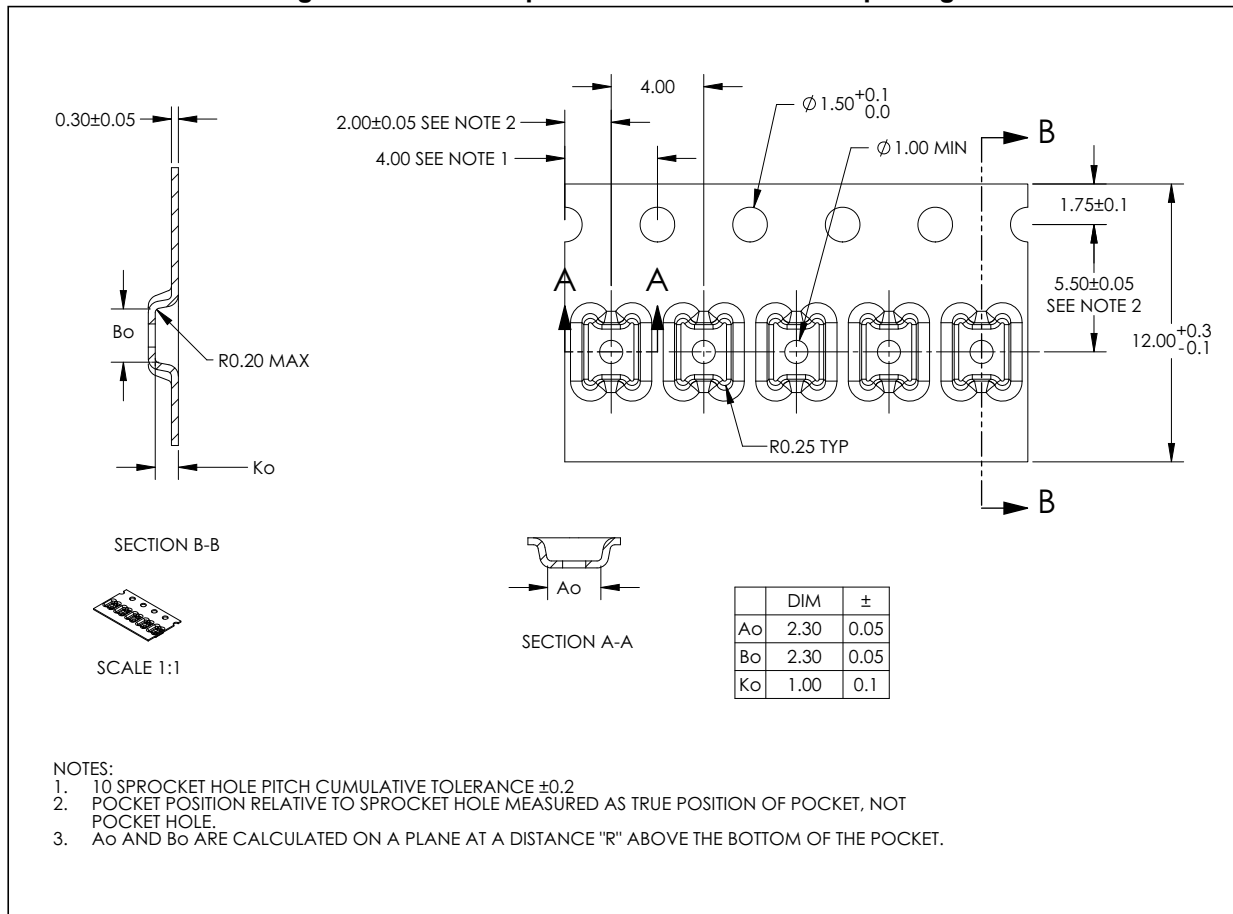

Figure 11. LGA-12 package orientation in carrier tape

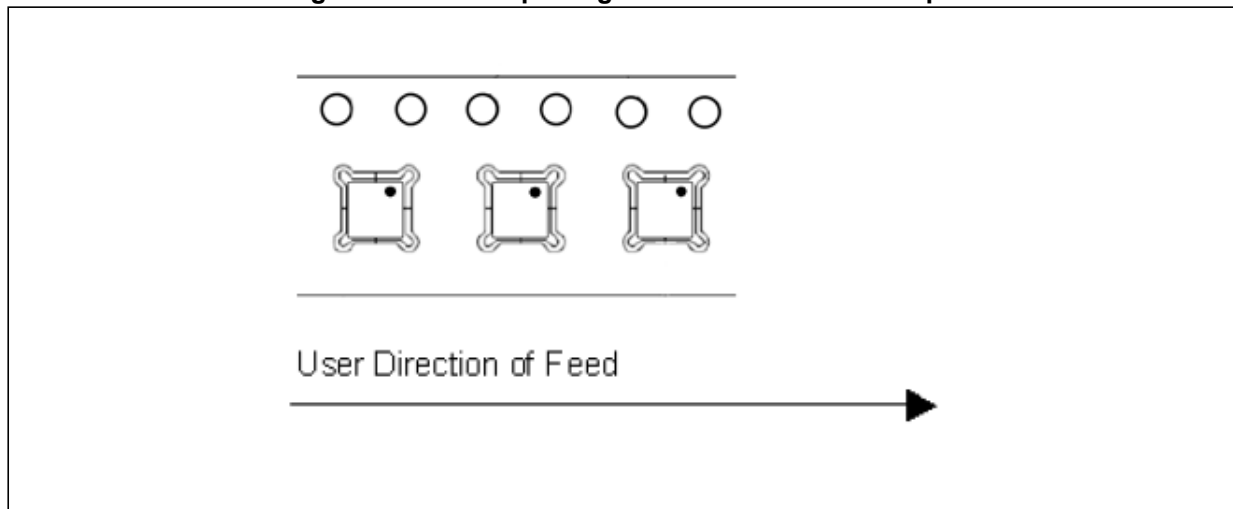

Figure 12. Reel information for carrier tape of LGA-12 package

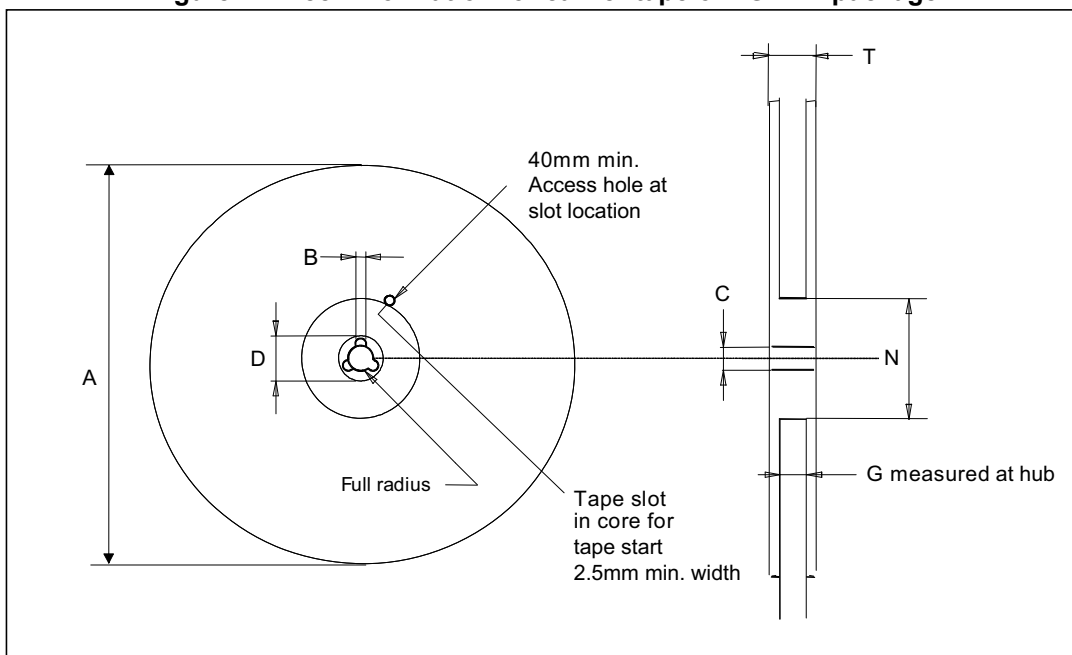

Table 48. Reel dimensions for carrier tape of LGA-12 package

Reel dimensions (mm)	
A (max)	330
B (min)	1.5
C	13 ±0.25
D (min)	20.2
N (min)	60
G	12.4 +2/-0
T (max)	18.4

## 10 Revision history

**Table 49. Document revision history**

Date	Revision	Changes
11-May-2017	1	Initial release
18-Jul-2017	2	Document status promoted to "Datasheet - production data"
21-Sep-2017	3	Updated <a href="#">Table 2: Pin description</a> Updated <a href="#">Table 5: Electrical characteristics</a> Updated <a href="#">Figure 3: SPI slave timing diagram</a> Removed <a href="#">Magnetometer offset cancellation</a> , <a href="#">Magnetometer interrupt</a> , <a href="#">Magnetometer hard-iron compensation</a> , and <a href="#">Self-test</a> Updated <a href="#">Section 5: Application hints</a> , <a href="#">Section 5.1: Soldering information</a> , and <a href="#">Section 5.3: Startup sequence</a> Updated <a href="#">Section 6: Digital interfaces</a> and <a href="#">Section 6.1: I<sup>2</sup>C serial interface</a> Updated <a href="#">CFG_REG_A (60h)</a> Specified default values in <a href="#">CFG_REG_B (61h)</a> Updated <a href="#">CFG_REG_C (62h)</a> Updated description of <a href="#">STATUS_REG (67h)</a> Updated description of <a href="#">OUTX_L_REG</a> , <a href="#">OUTX_H_REG (68h - 69h)</a> , <a href="#">OUTY_L_REG</a> , <a href="#">OUTY_H_REG (6Ah - 6Bh)</a> and <a href="#">TEMP_OUT_L_REG (6Eh)</a> , <a href="#">TEMP_OUT_H_REG (6Fh)</a>
07-Nov-2018	4	Added 4-wire SPI function to pin 7 (updated <a href="#">Figure 1</a> , <a href="#">Section 1.2: Pin description</a> , <a href="#">Section 5: Application hints</a> , <a href="#">Section 6: Digital interfaces</a> , and <a href="#">CFG_REG_C (62h)</a> )



**IMPORTANT NOTICE – PLEASE READ CAREFULLY**

STMicroelectronics NV and its subsidiaries (“ST”) reserve the right to make changes, corrections, enhancements, modifications, and improvements to ST products and/or to this document at any time without notice. Purchasers should obtain the latest relevant information on ST products before placing orders. ST products are sold pursuant to ST’s terms and conditions of sale in place at the time of order acknowledgement.

Purchasers are solely responsible for the choice, selection, and use of ST products and ST assumes no liability for application assistance or the design of Purchasers’ products.

No license, express or implied, to any intellectual property right is granted by ST herein.

Resale of ST products with provisions different from the information set forth herein shall void any warranty granted by ST for such product.

ST and the ST logo are trademarks of ST. All other product or service names are the property of their respective owners.

Information in this document supersedes and replaces information previously supplied in any prior versions of this document.

© 2018 STMicroelectronics – All rights reserved

## Данный компонент на территории Российской Федерации

### Вы можете приобрести в компании MosChip.

Для оперативного оформления запроса Вам необходимо перейти по данной ссылке:

<http://moschip.ru/get-element>

Вы можете разместить у нас заказ для любого Вашего проекта, будь то серийное производство или разработка единичного прибора.

В нашем ассортименте представлены ведущие мировые производители активных и пассивных электронных компонентов.

Нашей специализацией является поставка электронной компонентной базы двойного назначения, продукции таких производителей как XILINX, Intel (ex.ALTERA), Vicor, Microchip, Texas Instruments, Analog Devices, Mini-Circuits, Amphenol, Glenair.

Сотрудничество с глобальными дистрибьюторами электронных компонентов, предоставляет возможность заказывать и получать с международных складов практически любой перечень компонентов в оптимальные для Вас сроки.

На всех этапах разработки и производства наши партнеры могут получить квалифицированную поддержку опытных инженеров.

Система менеджмента качества компании отвечает требованиям в соответствии с ГОСТ Р ИСО 9001, ГОСТ РВ 0015-002 и ЭС РД 009

### Офис по работе с юридическими лицами:

105318, г.Москва, ул.Щербаковская д.3, офис 1107, 1118, ДЦ «Щербаковский»

Телефон: +7 495 668-12-70 (многоканальный)

Факс: +7 495 668-12-70 (доб.304)

E-mail: [info@moschip.ru](mailto:info@moschip.ru)

Skype отдела продаж:

moschip.ru

moschip.ru\_4

moschip.ru\_6

moschip.ru\_9