

SPECIFICATION

Part No. : **TCP.02.TR.01**

Product Name : 5.8GHz Omega Antenna Set - 5800MHz 3dBic
2* External WIFI Drone Antennas (Tx and Rx)
Circularly Polarized

Feature : Diameter 35mm, Height 30 mm
Frequency Range: 5600 - 6000 MHz
Peak Gain: 3 dBic typ.
Efficiency: 80% typ.
TX- Four Leaf Copper Wire antenna
RX- Four Leaf Copper Wire antenna
RP- SMA(M)
Cable type: Semi-rigid SS402
Total Length: 50 mm
RoHS Compliant



1. Introduction

The Omega 5.8 GHz clover leaf antenna set comprises of one each of a Tx and Rx antenna. They are omni-directional, high efficiency, circularly polarized antennas with a robust housing for UAV, FPV, and other wireless video transmission/receiving equipment. Circular polarized antennas are an ideal choice for UAV's because the signal link is much more stable (max 3dB decrease) in different orientations than when using a linear antenna where one could easily have a 20dB+ decrease depending on orientation.

The Omega features an excellent efficiency of over 70%. High efficiency antennas are needed for the higher throughput requirements of drone applications, especially high definition video streams.

Unlike most antennas in this market which are made in small workshops without RF chambers, Taoglas antennas are designed and manufactured in world class manufacturing facilities to the most stringent standards. We show the true polarization and gain performance tested in our multi-million dollar RF facilities. Most of our competitors just show theoretical circular polarized patterns and gains which are not indicative of anywhere close to the real circular polarization, many are actually linearly polarized at the frequencies of interest, in fact there is no small antenna of this type that can maintain true circular polarization across the whole WiFi band (true circular polarization being defined by the axial ratio being below 3). We have tested many antennas on the market and many of the competitors axial ratio performance of 10 and above indicate they are actually linear polarized antennas. Also, every Taoglas antenna must pass level quality control and records of every antenna performance are kept forever on our systems.

The Omega antenna set includes a clover leaf TX antenna and a clover leaf RX antenna. The antenna is simple to install on 5.8GHz video transmitters and receivers and features a circular, robust housing to protect the inner antenna structure during rough

landings. The Omega antenna is also IP65 water resistant.

Typical Applications

- First Person View (FPV) applications
- Unmanned Aerial Vehicles
- Quad-copters
- WIFI remote control applications

This antenna model implements highly quality SS402 semi-rigid cable which is RF microwave low loss cable for military and commercial aerospace applications. The cable can be bent to a fixed orientation, for ease of installation.

Cable length and connector types are customizable.

Taoglas can also customize and test antennas on your UAV in our worldwide facilities, in the US, Ireland or Taiwan, subject to NRE or MOQ [Contact](#) your regional Taoglas sales office for support.

Note – Taoglas also has a range of filters available to reduce interference from other transmitters and sources of noise. In this application Airvu 5.8G Band Pass SMA Filters attached between the antenna and your on-board connector are a great choice.

2. Specification Table

ELECTRICAL		
TCP.02 Antenna	TX	RX
Frequency (MHz)	5600~6000	
Impedance	50 Ohm	
VSWR	1.5 typ.	1.5 typ.
Efficiency	70% typ.	70% typ.
Return Loss (dB)	< -15	< -15
Peak Gain (dBi)	3 typ.	3 typ.
Polarization	LHCP (Left hand circularly polarized)	
Directionality	Omni	
Max. Input Power	10W	
MECHANICAL		
Dimensions (mm)	Ø35.6*30 (Only Dome)	
Antenna Body Material	PE	
Cable	SS-402	
Cable Length	50 mm	
Connector	SMA (M) RP	
Weight	11 g	
ENVIRONMENTAL		
Temperature Range	-40°C to 85°C	
Humidity	Non-condensing 65°C 95% RH	

3. Electrical Specifications

3.1 Return Loss

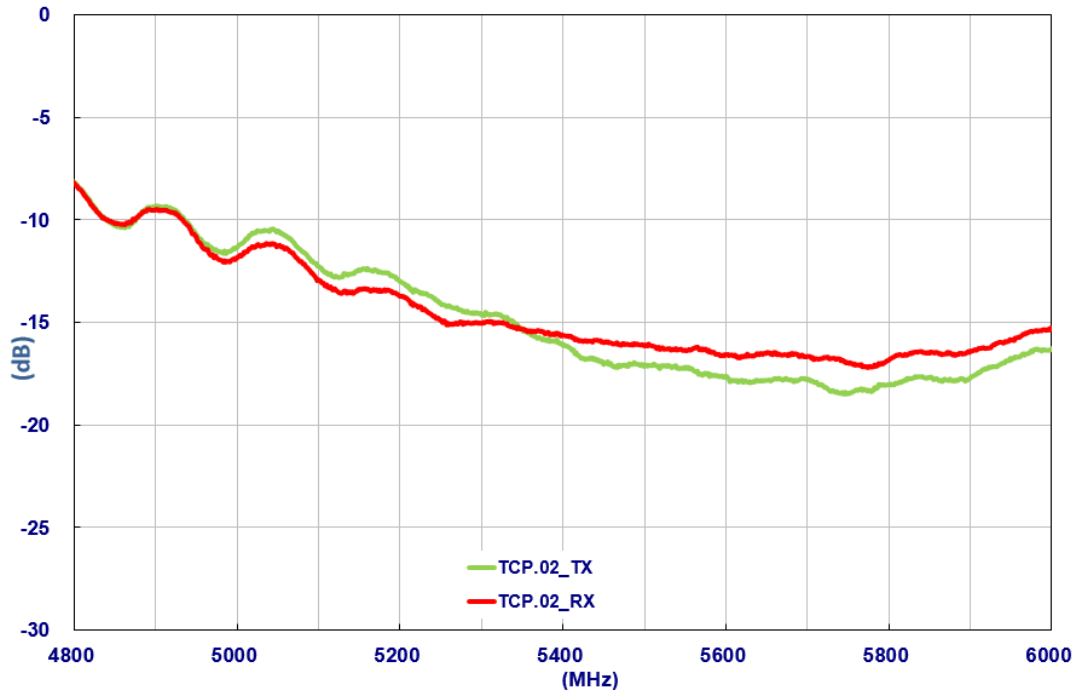

3.2 Efficiency

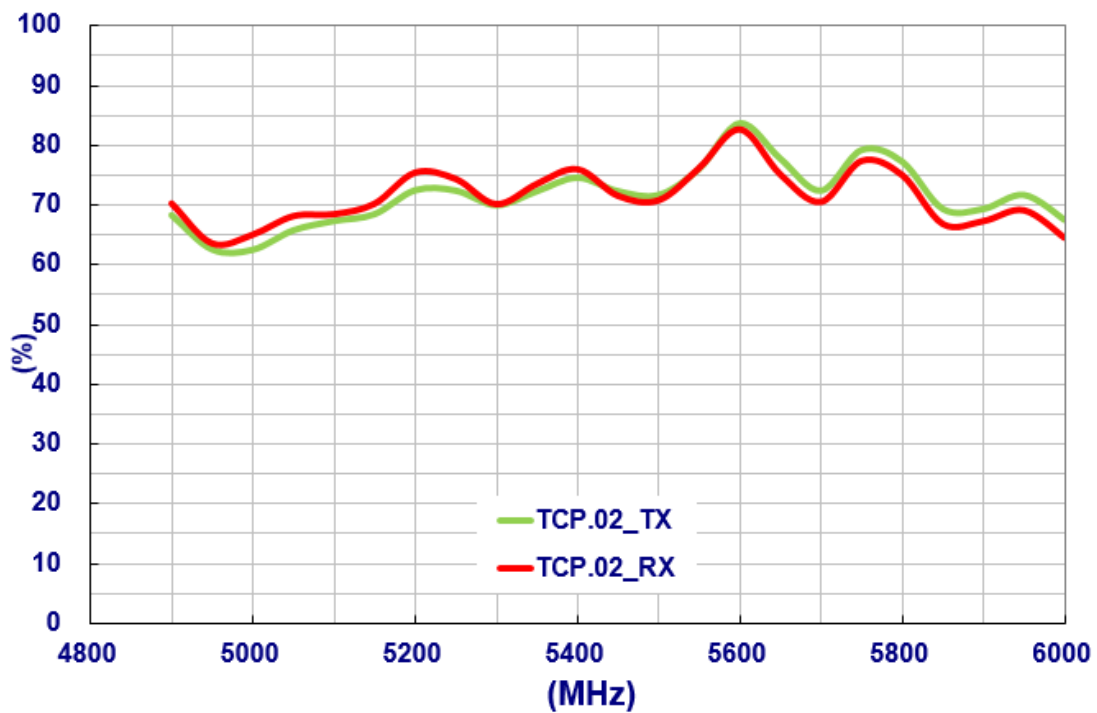

3.3 Peak Gain

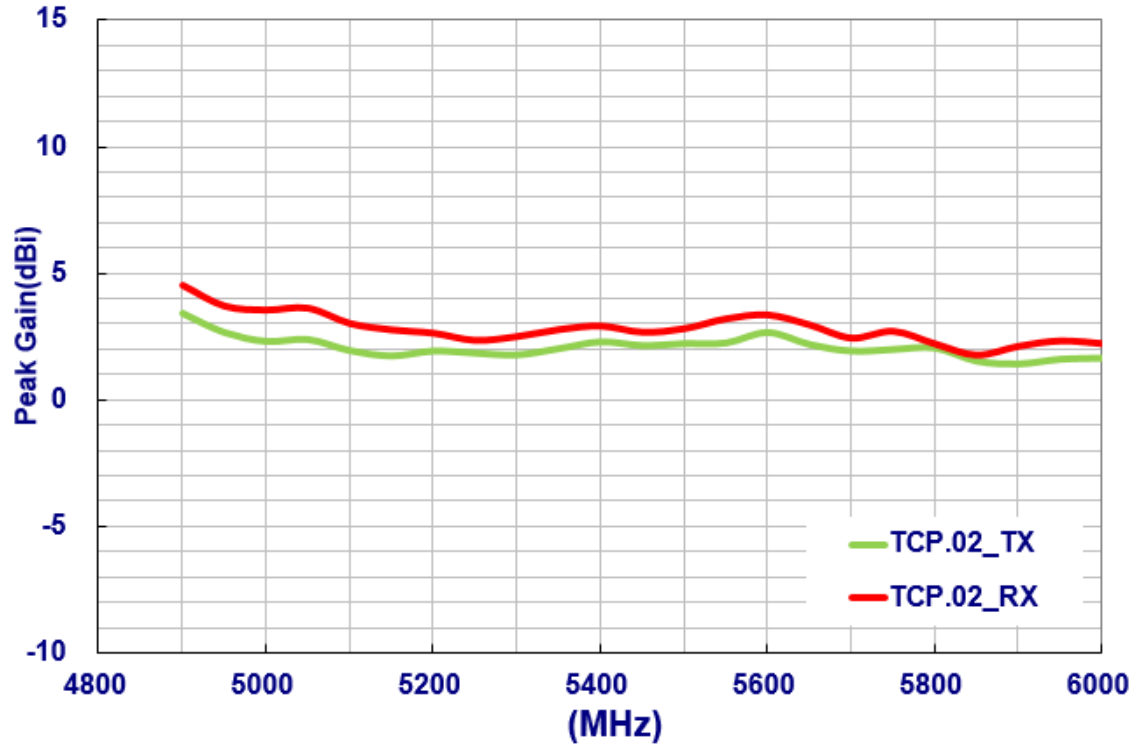

3.4 Average Gain

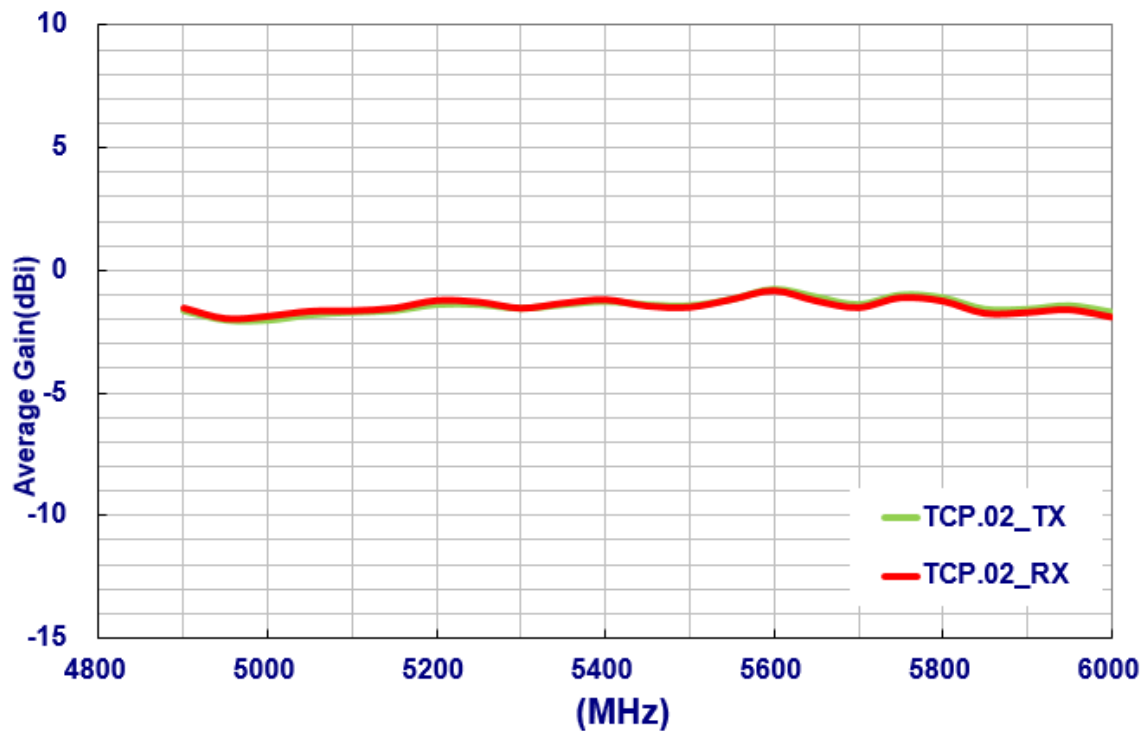

3.5 Axial Ratio

TX

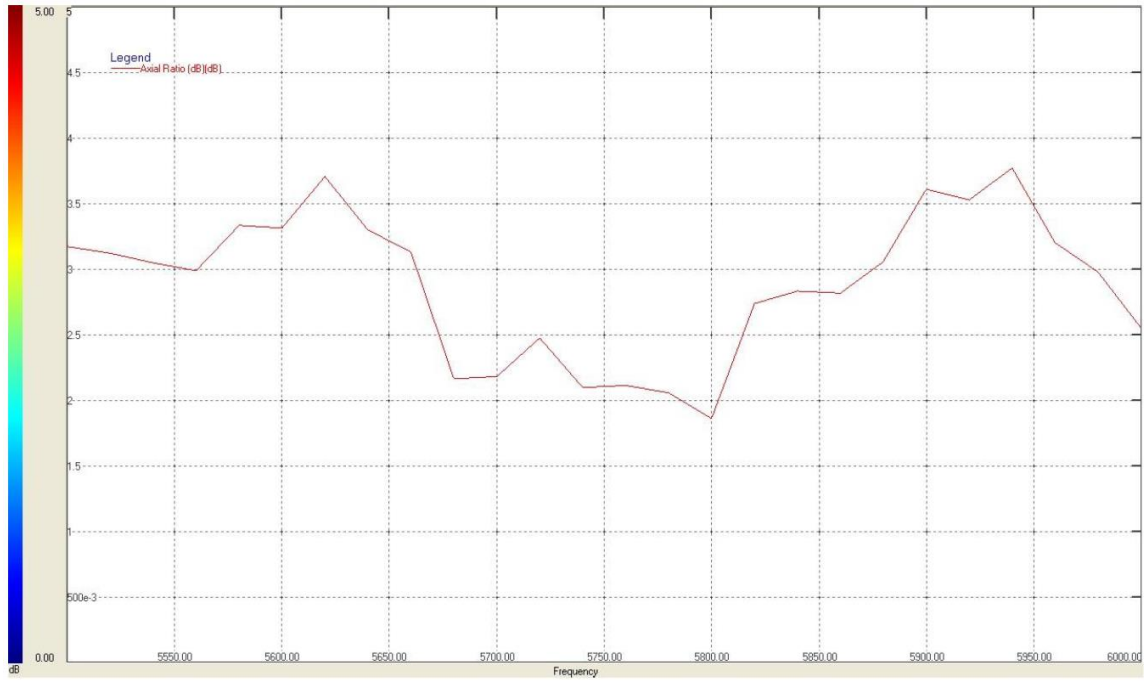

RX

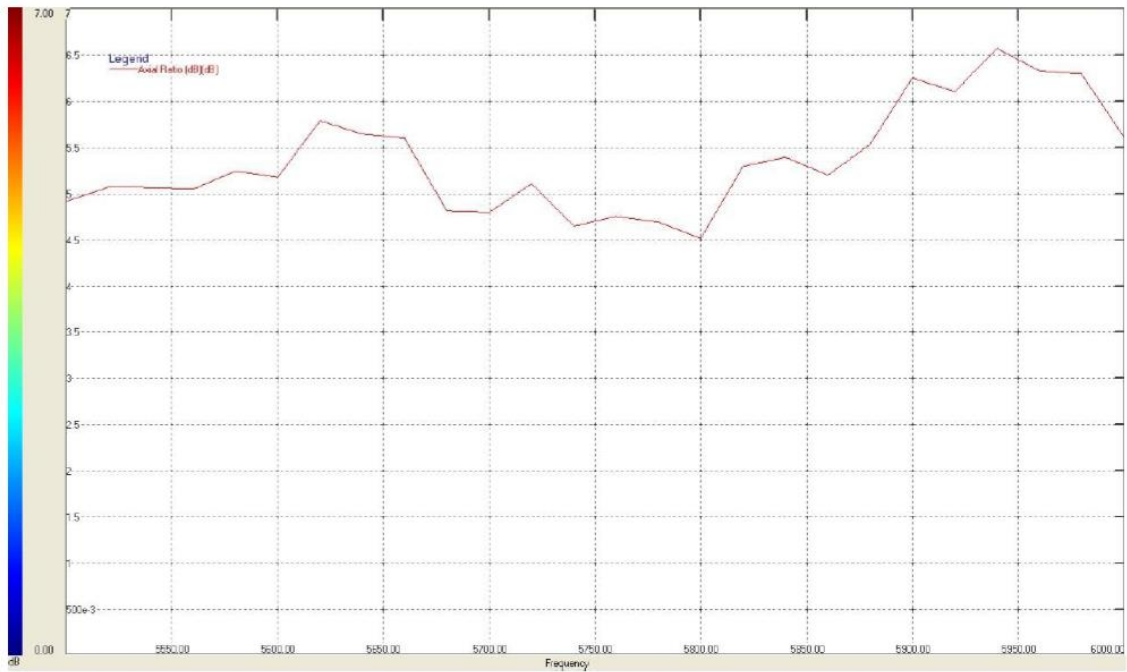

4. Radiation Patterns

The TCP.02 antennas were both tested in a CTIA certified ETS anechoic chamber. The test setup is shown below.

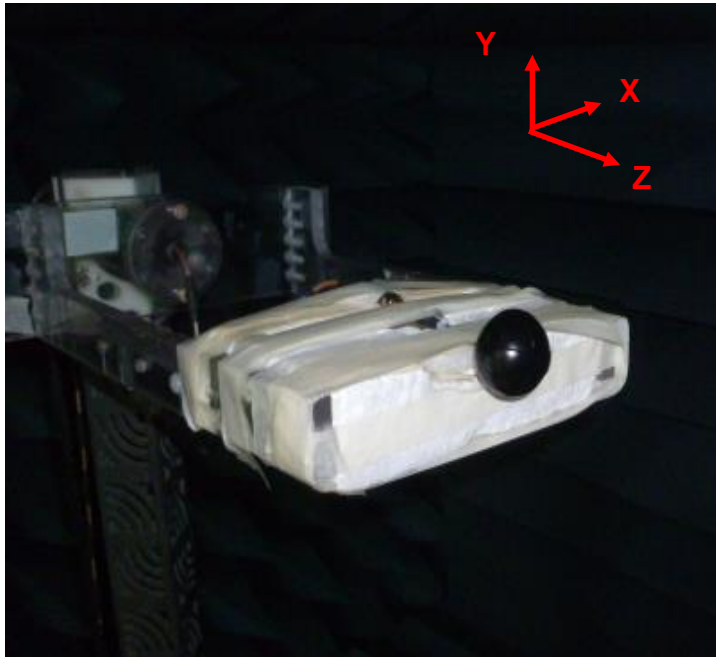

4.1 3D Radiation Pattern

TCP.02 TX Antenna @ 5800MHz

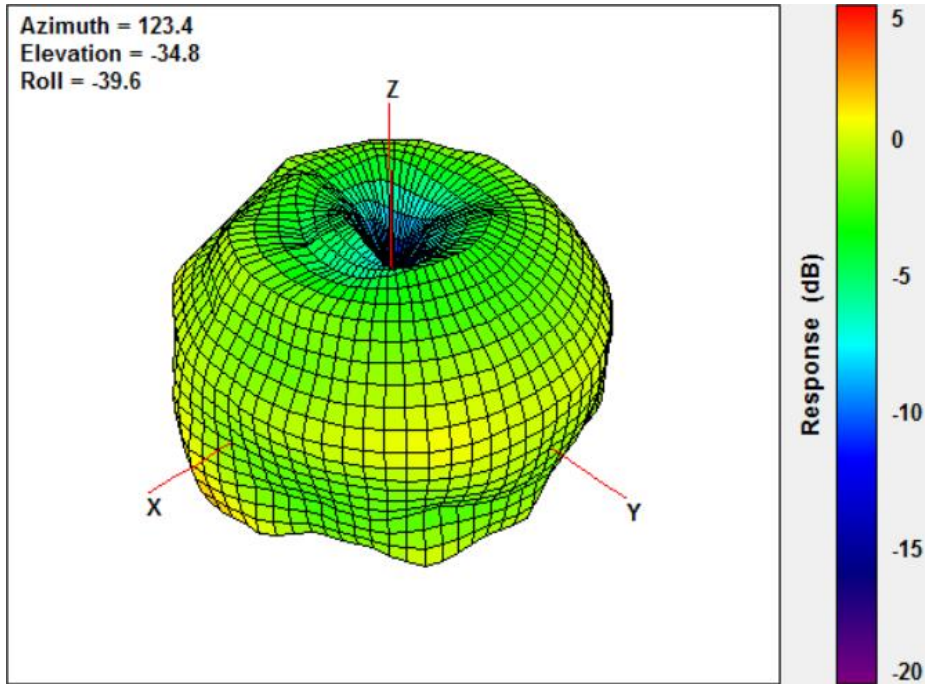

TCP.02 RX Antenna @ 5800MHz

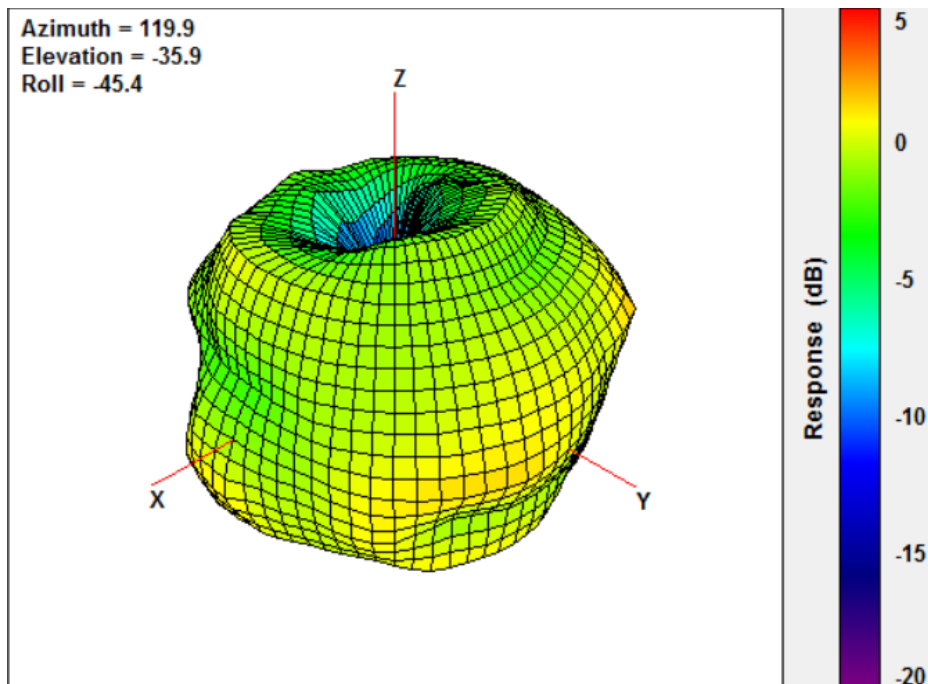

4.2 2D Radiation Pattern

TCP.02 TX Antenna

XY-Plane

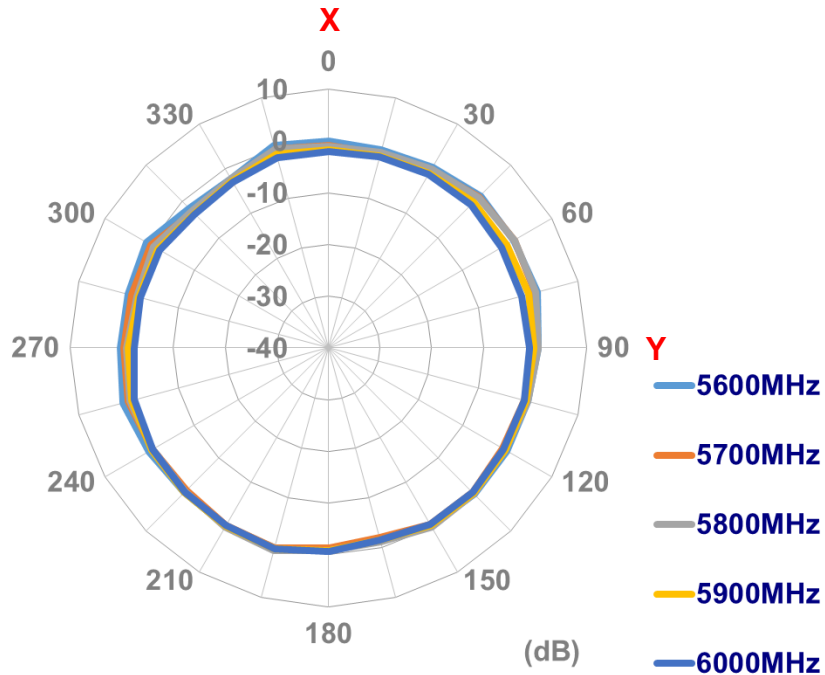

XZ-Plane

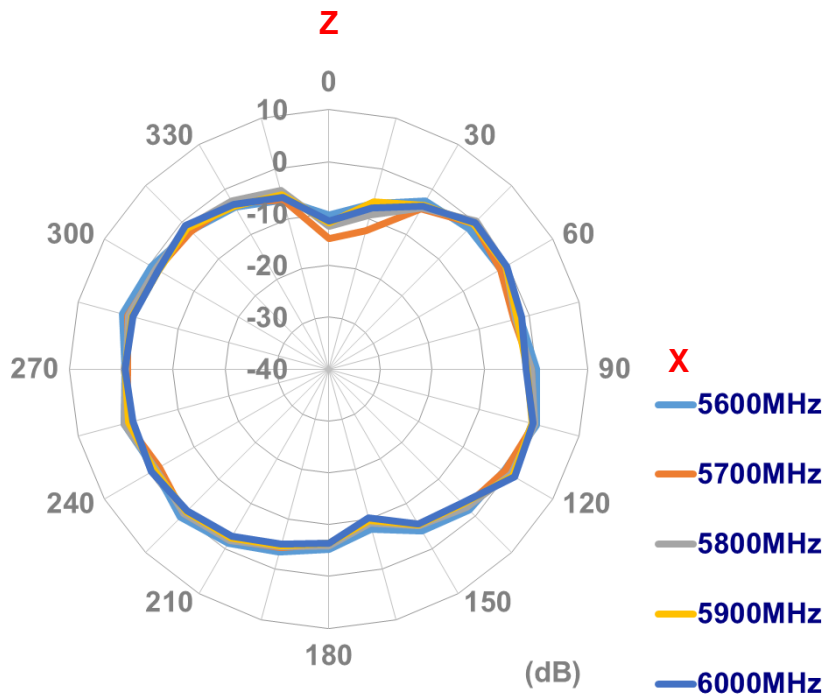



TAOGLAS[®]

YZ-Plane

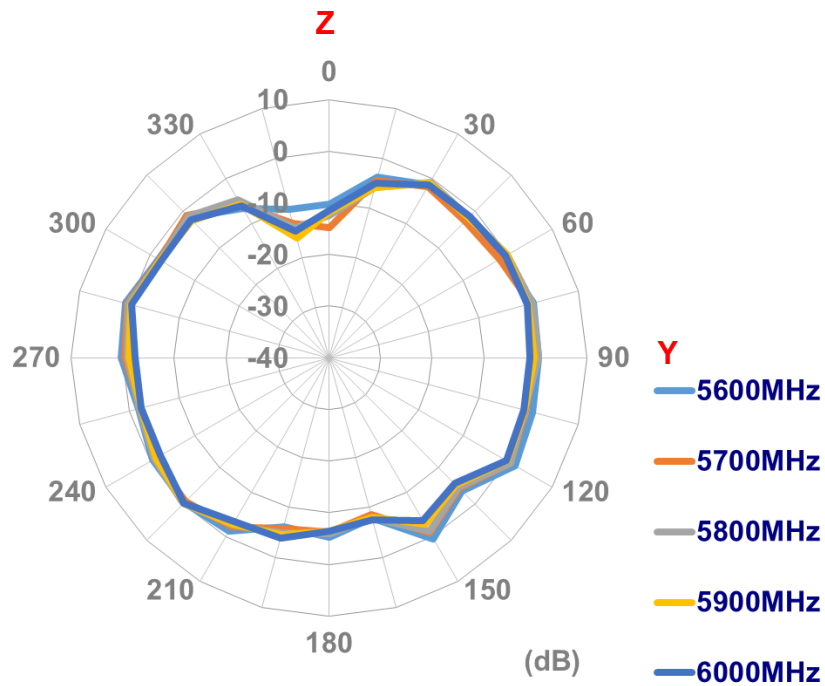

TCP.02 RX Antenna

XY-Plane

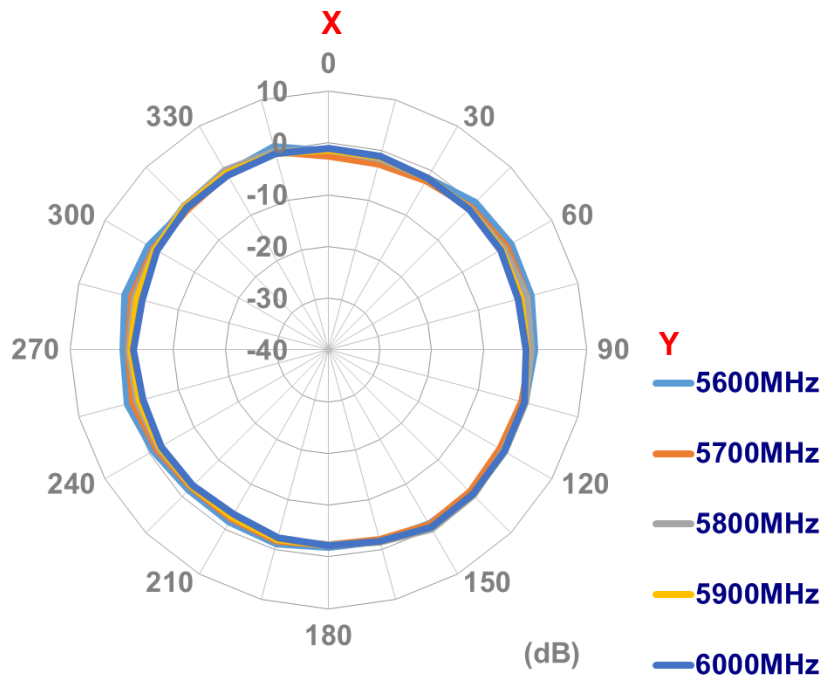



TAOGLAS®

XZ-Plane

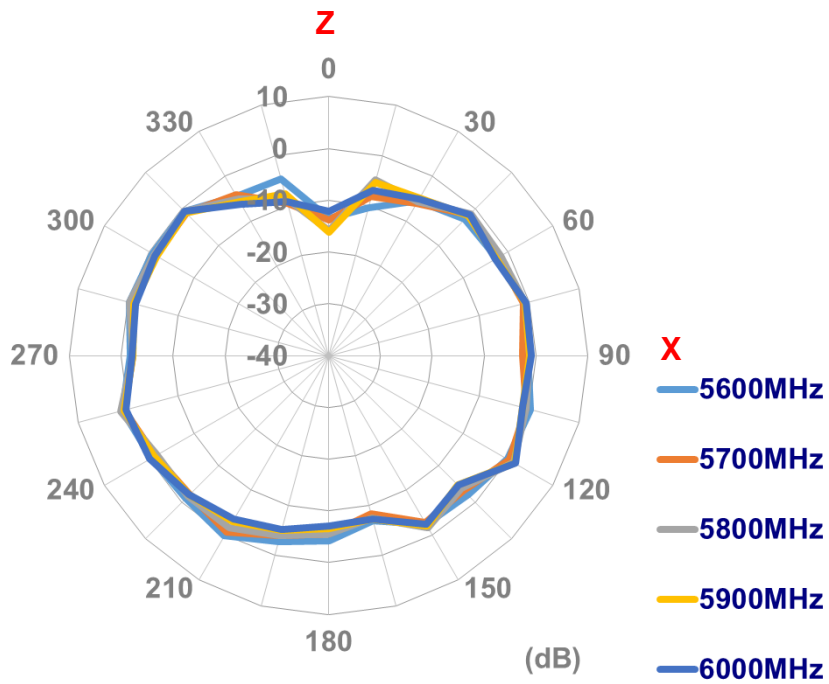

YZ-Plane

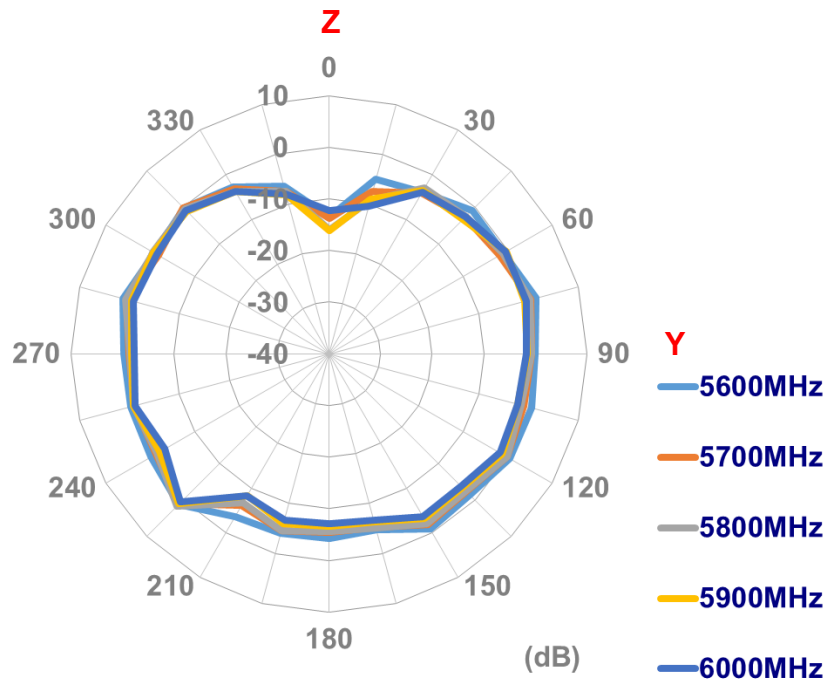

5. Mechanical Drawing

TCP.02 TX & RX Antennas are the same dimension.

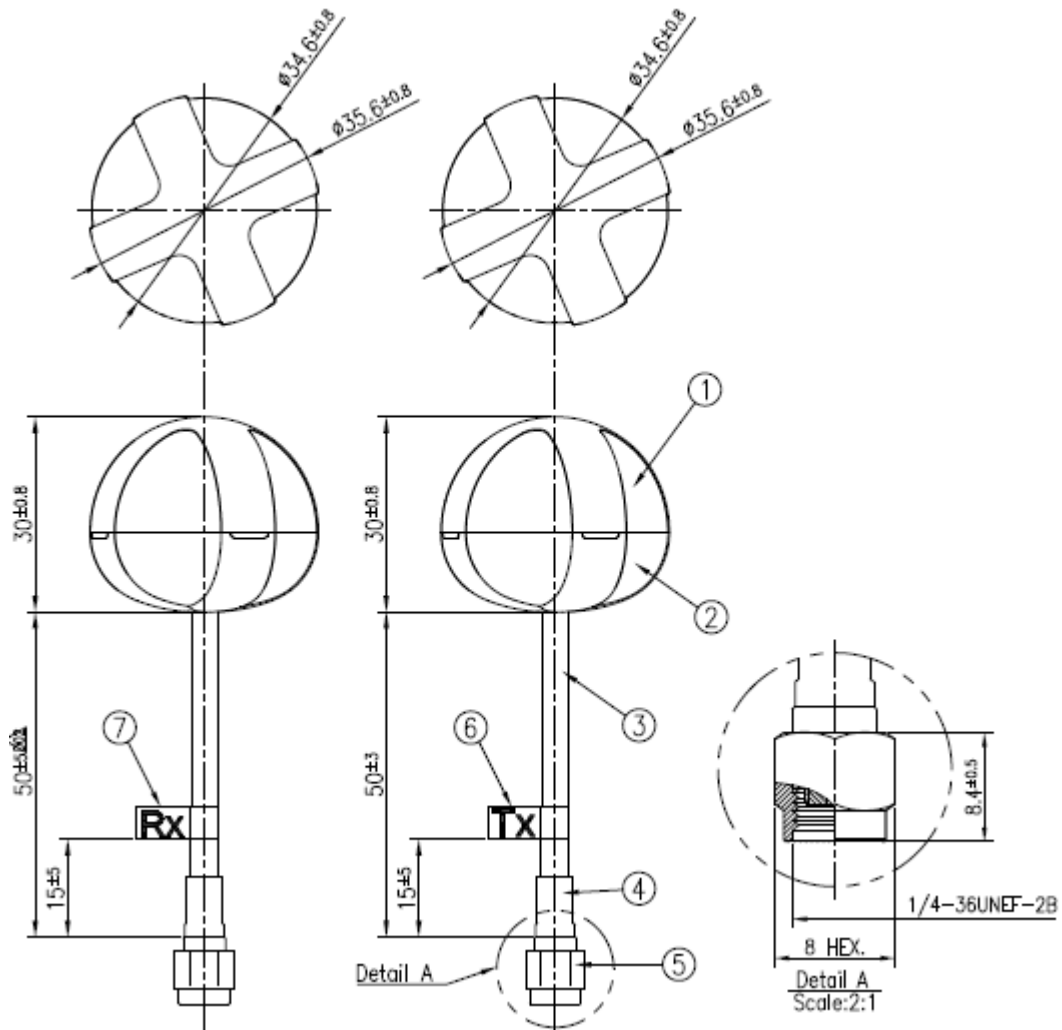

	Name	P/N	Material	Finish	QTY
1	Housing Top	000114L000007A	PC	Black	2
2	Housing Bottom	000114L010007A	PC	Black	2
3	SS402 Coaxial Cable	303614L000007A	PE	Black	2
4	Heat Shrink Tube	001314L000007A	PE	Black	2
5	RP-SMA(M)	200214L000007A	Brass	Gold	2
6	Tx Label	001014L000007A	PET	Silver	1
7	Rx Label	001014L010007A	PET	Silver	1

6. Packaging

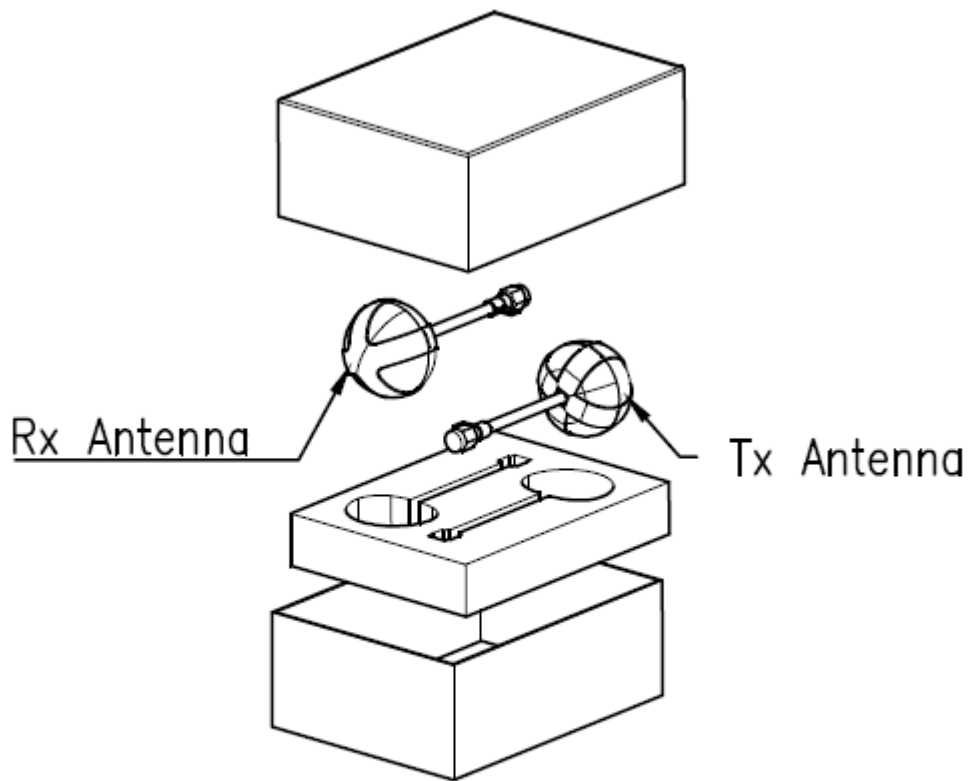

Package:
1 pc Tx Antenna and
1 pc Rx Antenna in Box.

TCP.02.TR.01

Packaging Specifications

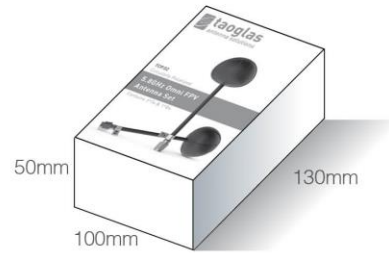

1 No. TCP.02.TR.01 per small box
 Box Dimensions - 130*50*100mm
 Weight - 160g



1 box per PE bag
 Carton Dimensions - 170*260mm
 Weight - 170g

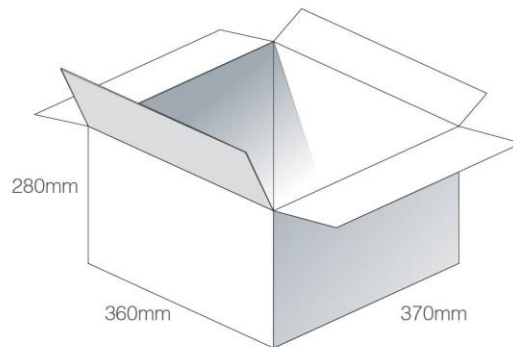

1 Outer Carton
 Carton Dimensions - 360*370*280mm
 42 pcs TCP.02.TR.01 per carton

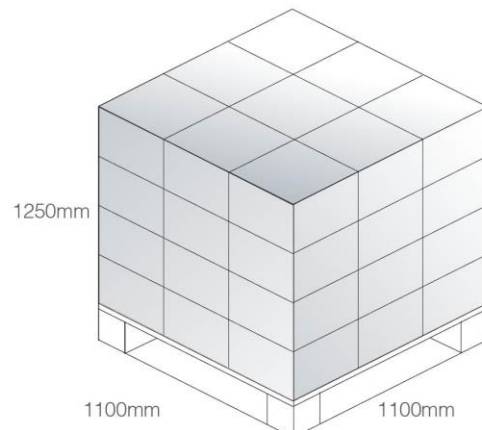

Pallet Dimensions 1100*1100*1250mm
 36 Cartons per Pallet
 9 Cartons per layer
 4 Layers

Данный компонент на территории Российской Федерации

Вы можете приобрести в компании MosChip.

Для оперативного оформления запроса Вам необходимо перейти по данной ссылке:

<http://moschip.ru/get-element>

Вы можете разместить у нас заказ для любого Вашего проекта, будь то серийное производство или разработка единичного прибора.

В нашем ассортименте представлены ведущие мировые производители активных и пассивных электронных компонентов.

Нашей специализацией является поставка электронной компонентной базы двойного назначения, продукции таких производителей как XILINX, Intel (ex.ALTERA), Vicor, Microchip, Texas Instruments, Analog Devices, Mini-Circuits, Amphenol, Glenair.

Сотрудничество с глобальными дистрибьюторами электронных компонентов, предоставляет возможность заказывать и получать с международных складов практически любой перечень компонентов в оптимальные для Вас сроки.

На всех этапах разработки и производства наши партнеры могут получить квалифицированную поддержку опытных инженеров.

Система менеджмента качества компании отвечает требованиям в соответствии с ГОСТ Р ИСО 9001, ГОСТ РВ 0015-002 и ЭС РД 009

Офис по работе с юридическими лицами:

105318, г.Москва, ул.Щербаковская д.3, офис 1107, 1118, ДЦ «Щербаковский»

Телефон: +7 495 668-12-70 (многоканальный)

Факс: +7 495 668-12-70 (доб.304)

E-mail: info@moschip.ru

Skype отдела продаж:

moschip.ru

moschip.ru_4

moschip.ru_6

moschip.ru_9