

## MODEL 805 ACCELEROMETER

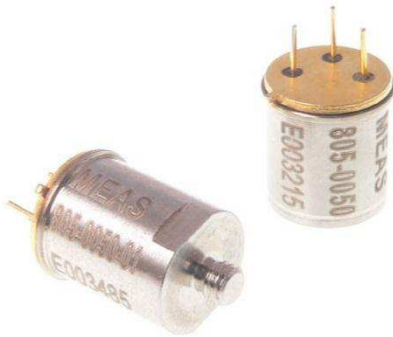

### SPECIFICATIONS

- ◆ **TO-5 Series Accelerometer**
- ◆ **2-Wire IEPE Interface**
- ◆ **Low-Cost, Embedded Applications**
- ◆ **Wide Bandwidth to 12kHz**

The **Model 805** is a miniature adhesive mount IEPE accelerometer built on a 3-pin TO-5 header. It is available in  $\pm 50g$  to  $\pm 500g$  dynamic ranges and offers a flat frequency response to 12kHz. The accelerometer features a hermetic construction in a TO-5 header configuration. The model 805 incorporates a stable piezo-ceramic crystal and an integrated charge converter amplifier in a 100% shielded housing suitable for many embedded OEM applications.

The model 805 accelerometer is offered in two configurations; one for adhesive mounting and one for stud mounting. An isolating cover option is also included for the standard model.

### FEATURES

- ◆  $\pm 50g$  to  $\pm 500g$  Range
- ◆ Wide bandwidth up to 12kHz
- ◆ TO-5 Configuration
- ◆ Hermetically Sealed
- ◆  $-40^{\circ}\text{C}$  to  $+100^{\circ}\text{C}$  Operating Range
- ◆ Case Grounded Design

### APPLICATIONS

- ◆ Machine Monitoring
- ◆ Embedded Preventive Maintenance
- ◆ Low-Cost OEM Installation
- ◆ Permanent Structural Study
- ◆ Embedded Sensing Solution

**PERFORMANCE SPECIFICATIONS**

All values are typical at +24°C, 80Hz and 4mA excitation unless otherwise stated. TE Connectivity reserves the right to update and change these specifications without notice.

**Parameters**

**DYNAMIC**

	±50	±100	±500	<b>Notes</b>
Range (g)	±50	±100	±500	
Sensitivity (mV/g)	100	50	10	±10% (see Note 1 for ±5% option)
Frequency Response (Hz)	1-8000	1-8000	1-8000	±1dB
Frequency Response (Hz)	0.3-10000	0.3-10000	0.3-12000	±3dB
Natural Frequency (Hz)	34000	34000	34000	
Non-Linearity (%FSO)	±1	±1	±1	
Transverse Sensitivity (%)	5	5	5	
Shock Limit (g)	5000	5000	5000	
Residual Noise (g RMS)	0.0004	0.0005	0.0009	Broadband 1Hz to 10kHz

**ELECTRICAL**

Compliance Voltage (Vdc)	18 to 30			
Excitation Current (mA)	2 to 10			
Bias Voltage (Vdc)	8 to 12			Room Temperature
Bias Voltage (Vdc)	6 to 13			-40 to +100°C
Output Impedance (Ω)	<100			
Full Scale Output Voltage (V)	±5			
Grounding	Case grounded to mounting surface			

**ENVIRONMENTAL**

Temperature Response (%)	±10			
Operating Temperature (°C)	-40 to +100			+120°C option, see Note 2
Storage Temperature (°C)	-54 to +125			

**PHYSICAL**

Sensing Element	Piezo-Ceramic
Case Material	Stainless Steel
Weight (grams)	5.0
Mounting	Adhesive or Circuit Board (M3 Stud Mounting for -01 Option)

<sup>1</sup> Contact factory for model number to order with ±5% sensitivity tolerance

<sup>2</sup> Contact factory for model number to order with +120°C operating temperature

**Calibration supplied:** CS-SENS-0100 NIST Traceable Amplitude Calibration at 80Hz

The information in this sheet has been carefully reviewed and is believed to be accurate; however, no responsibility is assumed for inaccuracies. Furthermore, this information does not convey to the purchaser of such devices any license under the patent rights to the manufacturer. TE Connectivity reserves the right to make changes without further notice to any product herein. TE Connectivity makes no warranty, representation or guarantee regarding the suitability of its product for any particular purpose, nor does TE Connectivity assume any liability arising out of the application or use of any product or circuit and specifically disclaims any and all liability, including without limitation consequential or incidental damages. Typical parameters can and do vary in different applications. All operating parameters must be validated for each customer application by customer's technical experts. TE Connectivity does not convey any license under its patent rights nor the rights of others.

# MODEL 805 ACCELEROMETER

## DIMENSIONS

### Standard Model 805

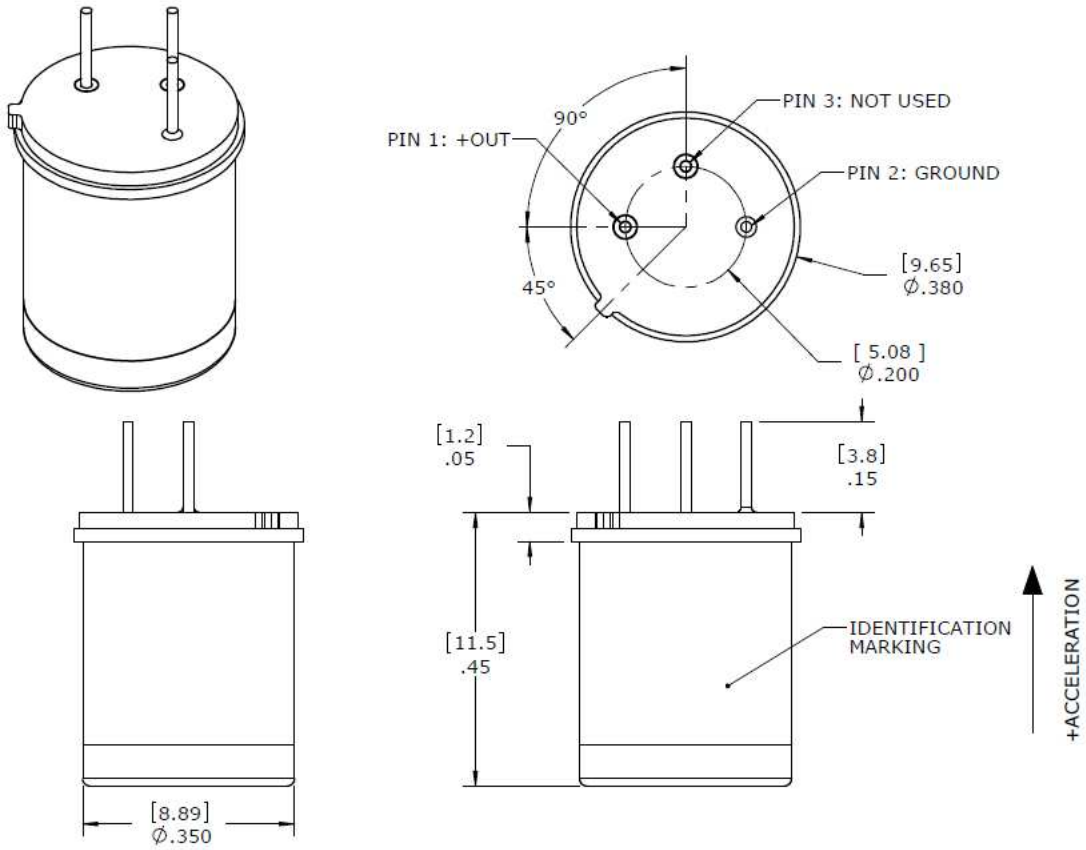

### Model 805 with M3 Mounting Stud Option



# MODEL 805 ACCELEROMETER

## SCHEMATIC



## ORDERING INFORMATION

<b>805</b>	<b>GGGG</b>	<b>XX</b>
<b>Range</b> 0050=50g 0100=100g 0500=500g		
<b>Options</b> 01=M3 x 0.5 Mounting Stud 02=Standard 805 unit with Isolating Mounting Cover Installed		



Isolating Cover Option

Examples;  
805-0050  
Model 805, 50g range

805-0100-01  
Model 805 with M3 mounting stud, 100g range

### NORTH AMERICA

Measurement Specialties, Inc.,  
a TE Connectivity Company  
Tel: 800-522-6752  
[customercare.hmp@te.com](mailto:customercare.hmp@te.com)

### EUROPE

MEAS France SAS  
a TE Connectivity Company  
Tel: +31 73 624 6999  
[customercare.lcsb@te.com](mailto:customercare.lcsb@te.com)

### ASIA

Measurement Specialties (China), Ltd.,  
a TE Connectivity Company  
Tel: 0400-820-6015  
[customercare.shzn@te.com](mailto:customercare.shzn@te.com)

### [TE.com/sensorsolutions](http://TE.com/sensorsolutions)

MEAS France SAS and Measurement Specialties (China), Inc., are TE Connectivity companies.

TE Connectivity, TE, TE connectivity (logo) are trademarks. All other logos, products and/or company names referred to herein might be trademarks of their respective owners.

The information given herein, including drawings, illustrations and schematics which are intended for illustration purposes only, is believed to be reliable. However, TE Connectivity makes no warranties as to its accuracy or completeness and disclaims any liability in connection with its use. TE Connectivity's obligations shall only be as set forth in TE Connectivity's Standard Terms and Conditions of Sale for this product and in no case will TE Connectivity be liable for any incidental, indirect or consequential damages arising out of the sale, resale, use or misuse of the product. Users of TE Connectivity products should make their own evaluation to determine the suitability of each such product for the specific application.

© 2017 TE Connectivity Ltd. All Rights Reserved.

## Данный компонент на территории Российской Федерации

### Вы можете приобрести в компании MosChip.

Для оперативного оформления запроса Вам необходимо перейти по данной ссылке:

<http://moschip.ru/get-element>

Вы можете разместить у нас заказ для любого Вашего проекта, будь то серийное производство или разработка единичного прибора.

В нашем ассортименте представлены ведущие мировые производители активных и пассивных электронных компонентов.

Нашей специализацией является поставка электронной компонентной базы двойного назначения, продукции таких производителей как XILINX, Intel (ex.ALTERA), Vicor, Microchip, Texas Instruments, Analog Devices, Mini-Circuits, Amphenol, Glenair.

Сотрудничество с глобальными дистрибьюторами электронных компонентов, предоставляет возможность заказывать и получать с международных складов практически любой перечень компонентов в оптимальные для Вас сроки.

На всех этапах разработки и производства наши партнеры могут получить квалифицированную поддержку опытных инженеров.

Система менеджмента качества компании отвечает требованиям в соответствии с ГОСТ Р ИСО 9001, ГОСТ РВ 0015-002 и ЭС РД 009

### Офис по работе с юридическими лицами:

105318, г.Москва, ул.Щербаковская д.3, офис 1107, 1118, ДЦ «Щербаковский»

Телефон: +7 495 668-12-70 (многоканальный)

Факс: +7 495 668-12-70 (доб.304)

E-mail: [info@moschip.ru](mailto:info@moschip.ru)

Skype отдела продаж:

moschip.ru

moschip.ru\_4

moschip.ru\_6

moschip.ru\_9