

# BFP450

Linear Low Noise Silicon Bipolar RF Transistor

## Datasheet

Revision 1.2, 2013-07-29

**Edition 2013-07-29**

**Published by  
Infineon Technologies AG  
81726 Munich, Germany**

**© 2013 Infineon Technologies AG  
All Rights Reserved.**

### **Legal Disclaimer**

The information given in this document shall in no event be regarded as a guarantee of conditions or characteristics. With respect to any examples or hints given herein, any typical values stated herein and/or any information regarding the application of the device, Infineon Technologies hereby disclaims any and all warranties and liabilities of any kind, including without limitation, warranties of non-infringement of intellectual property rights of any third party.

### **Information**

For further information on technology, delivery terms and conditions and prices, please contact the nearest Infineon Technologies Office ([www.infineon.com](http://www.infineon.com)).

### **Warnings**

Due to technical requirements, components may contain dangerous substances. For information on the types in question, please contact the nearest Infineon Technologies Office.

Infineon Technologies components may be used in life-support devices or systems only with the express written approval of Infineon Technologies, if a failure of such components can reasonably be expected to cause the failure of that life-support device or system or to affect the safety or effectiveness of that device or system. Life support devices or systems are intended to be implanted in the human body or to support and/or maintain and sustain and/or protect human life. If they fail, it is reasonable to assume that the health of the user or other persons may be endangered.

**BFP450, Linear Low Noise Silicon Bipolar RF Transistor**
**Revision History: 2013-07-29, Revision 1.2**

Page	Subjects (changes since previous revision)
	This datasheet replaces the revision from 2012-09-11. The product itself has not been changed and the device characteristics remain unchanged. Only the product description and information available in the datasheet have been expanded and updated.

**Trademarks of Infineon Technologies AG**

AURIX™, C166™, CanPAK™, CIPOS™, CIPURSE™, EconoPACK™, CoolMOS™, CoolSET™, CORECONTROL™, CROSSAVE™, DAVE™, DI-POL™, EasyPIM™, EconoBRIDGE™, EconoDUAL™, EconoPIM™, EconoPACK™, EiceDRIVER™, eupec™, FCOS™, HITFET™, HybridPACK™, I<sup>2</sup>RF™, ISOFACE™, IsoPACK™, MIPAQ™, ModSTACK™, my-d™, NovalithIC™, OptiMOS™, ORIGA™, POWERCODE™, PRIMARION™, PrimePACK™, PrimeSTACK™, PRO-SIL™, PROFET™, RASIC™, ReverSave™, SatRIC™, SIEGET™, SINDRION™, SIPMOS™, SmartLEWIS™, SOLID FLASH™, TEMPFET™, thinQ!™, TRENCHSTOP™, TriCore™.

**Other Trademarks**

Advance Design System™ (ADS) of Agilent Technologies, AMBA™, ARM™, MULTI-ICE™, KEIL™, PRIMECELL™, REALVIEW™, THUMB™, μVision™ of ARM Limited, UK. AUTOSAR™ is licensed by AUTOSAR development partnership. Bluetooth™ of Bluetooth SIG Inc. CAT-iq™ of DECT Forum. COLOSSUS™, FirstGPS™ of Trimble Navigation Ltd. EMV™ of EMVCo, LLC (Visa Holdings Inc.). EPCOS™ of Epcos AG. FLEXGO™ of Microsoft Corporation. FlexRay™ is licensed by FlexRay Consortium. HYPERTERMINAL™ of Hilgraeve Incorporated. IEC™ of Commission Electrotechnique Internationale. IrDA™ of Infrared Data Association Corporation. ISO™ of INTERNATIONAL ORGANIZATION FOR STANDARDIZATION. MATLAB™ of MathWorks, Inc. MAXIM™ of Maxim Integrated Products, Inc. MICROTEC™, NUCLEUS™ of Mentor Graphics Corporation. MIPI™ of MIPI Alliance, Inc. MIPS™ of MIPS Technologies, Inc., USA. muRata™ of MURATA MANUFACTURING CO., MICROWAVE OFFICE™ (MWO) of Applied Wave Research Inc., OmniVision™ of OmniVision Technologies, Inc. Openwave™ Openwave Systems Inc. RED HAT™ Red Hat, Inc. RFMD™ RF Micro Devices, Inc. SIRIUS™ of Sirius Satellite Radio Inc. SOLARIS™ of Sun Microsystems, Inc. SPANSION™ of Spansion LLC Ltd. Symbian™ of Symbian Software Limited. TAIYO YUDEN™ of Taiyo Yuden Co. TEAKLITE™ of CEVA, Inc. TEKTRONIX™ of Tektronix Inc. TOKO™ of TOKO KABUSHIKI KAISHA TA. UNIX™ of X/Open Company Limited. VERILOG™, PALLADIUM™ of Cadence Design Systems, Inc. VLYNQ™ of Texas Instruments Incorporated. VXWORKS™, WIND RIVER™ of WIND RIVER SYSTEMS, INC. ZETEX™ of Diodes Zetex Limited.

Last Trademarks Update 2011-11-11

## Table of Contents

	<b>Table of Contents</b> .....	4
	<b>List of Figures</b> .....	5
	<b>List of Tables</b> .....	6
<b>1</b>	<b>Product Brief</b> .....	7
<b>2</b>	<b>Features</b> .....	8
<b>3</b>	<b>Maximum Ratings</b> .....	9
<b>4</b>	<b>Thermal Characteristics</b> .....	10
<b>5</b>	<b>Electrical Characteristics</b> .....	11
5.1	DC Characteristics .....	11
5.2	General AC Characteristics .....	11
5.3	Frequency Dependent AC Characteristics .....	12
5.4	Characteristic DC Diagrams .....	16
5.5	Characteristic AC Diagrams .....	19
<b>6</b>	<b>Simulation Data</b> .....	26
<b>7</b>	<b>Package Information SOT343</b> .....	27

## List of Figures

Figure 4-1	Total Power Dissipation $P_{tot} = f(T_s)$ .....	10
Figure 5-1	BFP450 Testing Circuit. ....	12
Figure 5-2	Collector Current vs. Collector Emitter Voltage $I_C = f(V_{CE})$ , $I_B =$ Parameter in mA .....	16
Figure 5-3	DC Current Gain $h_{FE} = f(I_C)$ , $V_{CE} = 3$ V .....	16
Figure 5-4	Collector Current vs. Base Emitter Voltage $I_C = f(V_{BE})$ , $V_{CE} = 2$ V. ....	17
Figure 5-5	Base Current vs. Base Emitter Forward Voltage $I_B = f(V_{BE})$ , $V_{CE} = 2$ V .....	17
Figure 5-6	Base Current vs. Base Emitter Reverse Voltage $I_B = f(V_{EB})$ , $V_{CE} = 2$ V .....	18
Figure 5-7	Transition Frequency $f_T = f(I_C)$ , $f = 1$ GHz, $V_{CE} =$ Parameter in V .....	19
Figure 5-8	3rd Order Intercept Point $OIP3 = f(I_C)$ , $Z_S = Z_L = 50 \Omega$ , $V_{CE}$ , $f =$ Parameters .....	19
Figure 5-9	Collector Base Capacitance $C_{CB} = f(V_{CB})$ , $f = 1$ MHz .....	20
Figure 5-10	Gain $G_{ma}$ , $G_{ms}$ , $ S_{21} ^2 = f(f)$ , $V_{CE} = 3$ V, $I_C = 90$ mA .....	20
Figure 5-11	Maximum Power Gain $G_{max} = f(I_C)$ , $V_{CE} = 3$ V, = Parameter in GHz. ....	21
Figure 5-12	Maximum Power Gain $G_{max} = f(V_{CE})$ , $I_C = 90$ mA, = Parameter in GHz .....	21
Figure 5-13	Input Matching $S_{11} = f(f)$ , $V_{CE} = 3$ V, $I_C = 50 / 90$ mA. ....	22
Figure 5-14	Source Impedance for Minimum Noise Figure = $f(f)$ , $V_{CE} = 3$ V, $I_C = 50 / 90$ mA .....	22
Figure 5-15	Output Matching $S_{22} = f(f)$ , $V_{CE} = 3$ V, $I_C = 50 / 90$ mA .....	23
Figure 5-16	Noise Figure $NF_{min} = f(f)$ , $V_{CE} = 3$ V, $I_C = 50 / 90$ mA, $Z_S = Z_{opt}$ .....	23
Figure 5-17	Noise Figure $NF_{min} = f(I_C)$ , $V_{CE} = 3$ V, $Z_S = Z_{opt} =$ Parameter in GHz. ....	24
Figure 5-18	Noise Figure $NF_{50} = f(I_C)$ , $V_{CE} = 3$ V, $Z_S = 50 \Omega =$ Parameter in GHz .....	24
Figure 5-19	Comparison Noise Figure $NF_{50} / NF_{min} = f(I_C)$ , $V_{CE} = 3$ V, $f = 1.9$ GHz .....	25
Figure 7-1	Package Outline .....	27
Figure 7-2	Package Footprint. ....	27
Figure 7-3	Marking Description (Marking BFP450: ANs).....	27
Figure 7-4	Tape Dimensions .....	27

## List of Tables

Table 3-1	Maximum Ratings	9
Table 4-1	Thermal Resistance	10
Table 5-1	DC Characteristics at $T_A = 25\text{ °C}$	11
Table 5-2	General AC Characteristics at $T_A = 25\text{ °C}$	11
Table 5-3	AC Characteristics, $V_{CE} = 3\text{ V}$ , $f = 150\text{ MHz}$	12
Table 5-4	AC Characteristics, $V_{CE} = 3\text{ V}$ , $f = 450\text{ MHz}$	13
Table 5-5	AC Characteristics, $V_{CE} = 3\text{ V}$ , $f = 900\text{ MHz}$	13
Table 5-6	AC Characteristics, $V_{CE} = 3\text{ V}$ , $f = 1.5\text{ GHz}$	14
Table 5-7	AC Characteristics, $V_{CE} = 3\text{ V}$ , $f = 1.9\text{ GHz}$	14
Table 5-8	AC Characteristics, $V_{CE} = 3\text{ V}$ , $f = 2.4\text{ GHz}$	15
Table 5-9	AC Characteristics, $V_{CE} = 3\text{ V}$ , $f = 3.5\text{ GHz}$	15

## 1 Product Brief

The BFP450 is a high linearity wideband NPN bipolar RF transistor. The collector design supports voltages up to  $V_{CE0} = 4.5\text{ V}$  and currents up to  $I_C = 170\text{ mA}$ . With its high linearity at currents as low as 50 mA the device supports energy efficient designs. The typical transition frequency is approximately 24 GHz, hence the device offers high power gain at frequencies up to 3 GHz in amplifier applications. The device is housed in an easy to use plastic package with visible leads.

## 2 Features

- Highly linear low noise driver amplifier for all RF frontends up to 3 GHz
- Based on Infineon’s reliable high volume 25 GHz silicon bipolar technology
- Output compression point  $OP_{1dB} = 19$  dBm at 90 mA, 3 V, 1.9 GHz, 50  $\Omega$  system
- Output 3rd order intermodulation point  $OIP3 = 31$  dBm at 90 mA, 3 V, 1.9 GHz, 50  $\Omega$  system
- Maximum available gain  $G_{ma} = 15.5$  dB at 50 mA, 3 V, 1.9 GHz
- Minimum noise figure  $NF_{min} = 1.7$  dB at 50 mA, 3 V, 1.9 GHz
- Pb-free (RoHS compliant) and halogen-free package with visible leads
- Qualification report according to AEC-Q101 available

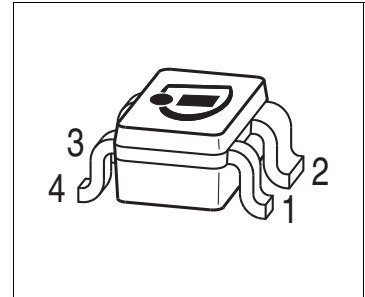

### Applications Examples

Driver amplifier

- ISM bands 434 and 868 MHz
- 1.9 GHz cordless phones
- CATV LNA

Transmitter driver amplifier

- 2.4 GHz WLAN and Bluetooth

Output stage LNA for active antennas

- TV, GPS, SDARS, 2.4 GHz WLAN, etc

Suitable for 3 - 5.5 GHz oscillators

**Attention: ESD (Electrostatic discharge) sensitive device, observe handling precautions**

Product Name	Package	Pin Configuration				Marking
BFP450	SOT343	1 = B	2 = E	3 = C	4 = E	ANs



### 3 Maximum Ratings

Table 3-1 Maximum Ratings

Parameter	Symbol	Values		Unit	Note / Test Condition
		Min.	Max.		
Collector emitter voltage	$V_{CEO}$	–	4.5	V	Open base $T_A = 25\text{ °C}$
		–	4.1	V	$T_A = -55\text{ °C}$
Collector emitter voltage	$V_{CES}$	–	15	V	E-B short circuited
Collector base voltage	$V_{CBO}$	–	15	V	Open emitter
Emitter base voltage	$V_{EBO}$	–	1.5	V	Open collector
Collector current	$I_C$	–	170	mA	–
Base current	$I_B$	–	10	mA	–
Total power dissipation <sup>1)</sup>	$P_{tot}$	–	500	mW	$T_S \leq 90\text{ °C}$
Junction temperature	$T_J$	–	150	°C	–
Storage temperature	$T_{Stg}$	-55	150	°C	–

1)  $T_S$  is the soldering point temperature.  $T_S$  is measured on the emitter lead at the soldering point of the pcb.

**Attention: Stresses above the max. values listed here may cause permanent damage to the device. Exposure to absolute maximum rating conditions for extended periods may affect device reliability. Maximum ratings are absolute ratings; exceeding only one of these values may cause irreversible damage to the integrated circuit.**

## 4 Thermal Characteristics

Table 4-1 Thermal Resistance

Parameter	Symbol	Values			Unit	Note / Test Condition
		Min.	Typ.	Max.		
Junction - soldering point <sup>1)</sup>	$R_{thJS}$	–	120	–	K/W	–

1) For the definition of  $R_{thJS}$  please refer to Application Note AN077 (Thermal Resistance Calculation)

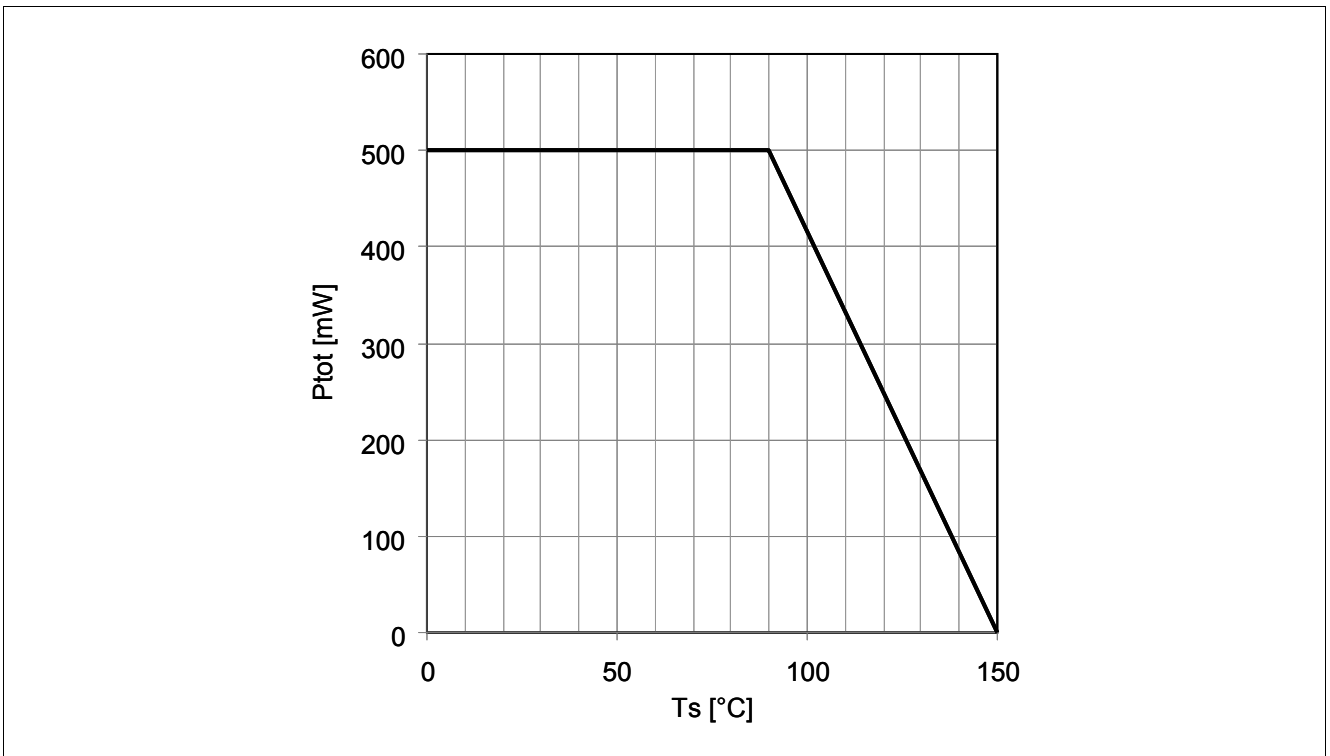

Figure 4-1 Total Power Dissipation  $P_{tot} = f(T_s)$

## 5 Electrical Characteristics

### 5.1 DC Characteristics

**Table 5-1 DC Characteristics at  $T_A = 25\text{ °C}$** 

Parameter	Symbol	Values			Unit	Note / Test Condition
		Min.	Typ.	Max.		
Collector emitter breakdown voltage	$V_{(BR)CEO}$	4.5	5	–	V	$I_C = 1\text{ mA}$ , $I_B = 0$ Open base
Collector emitter leakage current	$I_{CES}$	–	–	1 <sup>1)</sup>	$\mu\text{A}$	$V_{CE} = 15\text{ V}$ , $V_{BE} = 0$ $V_{CE} = 3\text{ V}$ , $V_{BE} = 0$ E-B short circuited
		–	1	30 <sup>1)</sup>	nA	
Collector base leakage current	$I_{CBO}$	–	1	30 <sup>1)</sup>	nA	$V_{CB} = 3\text{ V}$ , $I_E = 0$ Open emitter
Emitter base leakage current	$I_{EBO}$	–	0.05	3 <sup>1)</sup>	$\mu\text{A}$	$V_{EB} = 0.5\text{ V}$ , $I_C = 0$ Open collector
DC current gain	$h_{FE}$	60	95	130		$V_{CE} = 4\text{ V}$ , $I_C = 50\text{ mA}$ $V_{CE} = 3\text{ V}$ , $I_C = 90\text{ mA}$ Pulse measured
		50	85	120		

1) Maximum values not limited by the device but the short cycle time of the 100% test

### 5.2 General AC Characteristics

**Table 5-2 General AC Characteristics at  $T_A = 25\text{ °C}$** 

Parameter	Symbol	Values			Unit	Note / Test Condition
		Min.	Typ.	Max.		
Transition frequency	$f_T$	18	24	–	GHz	$V_{CE} = 3\text{ V}$ , $I_C = 90\text{ mA}$ , $f = 1\text{ GHz}$
Collector base capacitance	$C_{CB}$	–	0.48	0.8	pF	$V_{CB} = 3\text{ V}$ , $V_{BE} = 0\text{ V}$ $f = 1\text{ MHz}$ Emitter grounded
Collector emitter capacitance	$C_{CE}$	–	1.2	–	pF	$V_{CE} = 3\text{ V}$ , $V_{BE} = 0\text{ V}$ $f = 1\text{ MHz}$ Base grounded
Emitter base capacitance	$C_{EB}$	–	1.7	–	pF	$V_{EB} = 0.5\text{ V}$ , $V_{CB} = 0\text{ V}$ $f = 1\text{ MHz}$ Collector grounded

### 5.3 Frequency Dependent AC Characteristics

Measurement setup is a test fixture with Bias T's in a 50 Ω system,  $T_A = 25\text{ °C}$

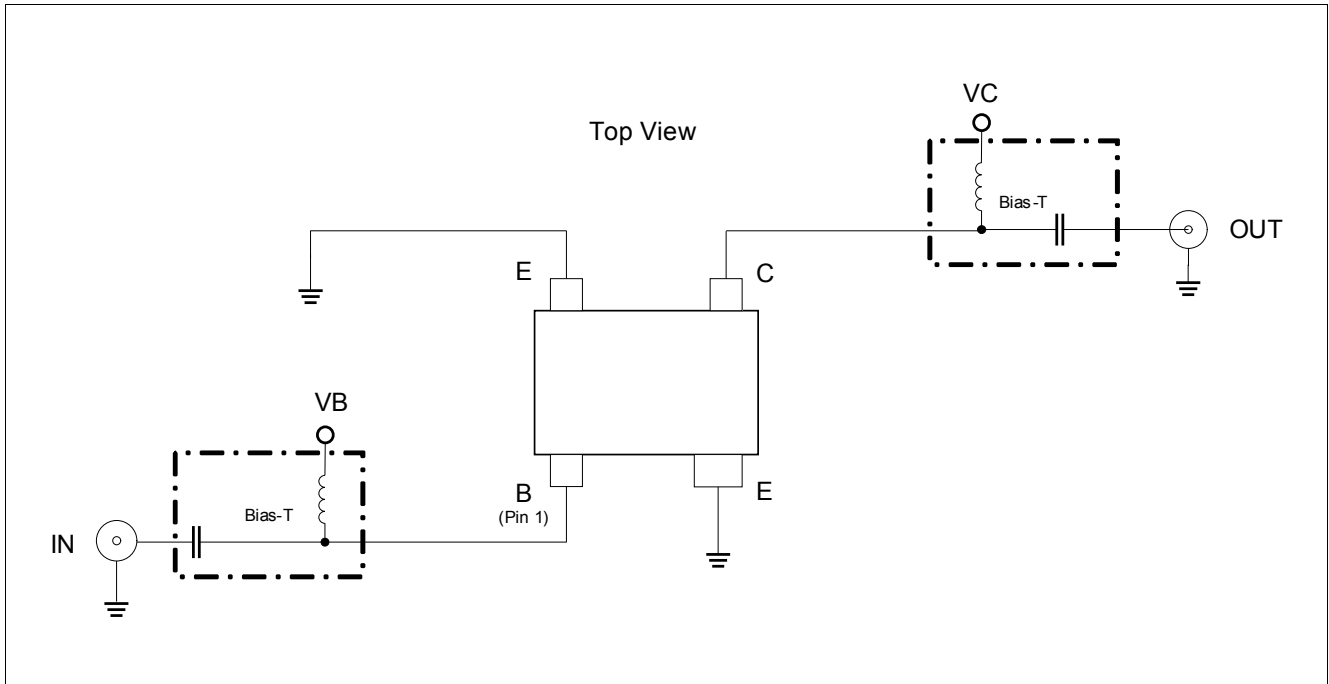

Figure 5-1 BFP450 Testing Circuit

Table 5-3 AC Characteristics,  $V_{CE} = 3\text{ V}$ ,  $f = 150\text{ MHz}$

Parameter	Symbol	Values			Unit	Note / Test Condition
		Min.	Typ.	Max.		
<b>Maximum power gain</b>					dB	
High linearity operation point	$G_{ms}$	–	34.5	–		$I_C = 50\text{ mA}$
Class A operation point	$G_{ms}$	–	35.5	–		$I_C = 90\text{ mA}$
<b>Transducer gain</b>					dB	$Z_S = Z_L = 50\text{ }\Omega$
High linearity operation point	$S_{21}$	–	33	–		$I_C = 50\text{ mA}$
Class A operation point	$S_{21}$	–	33.5	–		$I_C = 90\text{ mA}$
<b>Minimum noise figure</b>					dB	$Z_S = Z_{opt}$
Minimum noise figure	$NF_{min}$	–	1.55	–		$I_C = 50\text{ mA}$
Associated gain	$G_{ass}$	–	32	–		$I_C = 50\text{ mA}$
<b>Linearity</b>					dBm	$Z_S = Z_L = 50\text{ }\Omega$
1 dB gain compression point	$OP_{1dB}$	–	19	–		$I_C = 90\text{ mA}$
3rd order intercept point	$OIP3$	–	30.5	–		$I_C = 90\text{ mA}$

**Table 5-4 AC Characteristics,  $V_{CE} = 3\text{ V}$ ,  $f = 450\text{ MHz}$** 

Parameter	Symbol	Values			Unit	Note / Test Condition
		Min.	Typ.	Max.		
<b>Maximum power gain</b>					dB	
High linearity operation point	$G_{ms}$	–	28.5	–		$I_C = 50\text{ mA}$
Class A operation point	$G_{ms}$	–	29	–		$I_C = 90\text{ mA}$
<b>Transducer gain</b>					dB	$Z_S = Z_L = 50\ \Omega$
High linearity operation point	$S_{21}$	–	25	–		$I_C = 50\text{ mA}$
Class A operation point	$S_{21}$	–	25	–		$I_C = 90\text{ mA}$
<b>Minimum noise figure</b>					dB	$Z_S = Z_{opt}$
Minimum noise figure	$NF_{min}$	–	1.55	–		$I_C = 50\text{ mA}$
Associated gain	$G_{ass}$	–	27.5	–		$I_C = 50\text{ mA}$
<b>Linearity</b>					dBm	$Z_S = Z_L = 50\ \Omega$
1 dB gain compression point	$OP_{1dB}$	–	19	–		$I_C = 90\text{ mA}$
3rd order intercept point	$OIP3$	–	30	–		$I_C = 90\text{ mA}$

**Table 5-5 AC Characteristics,  $V_{CE} = 3\text{ V}$ ,  $f = 900\text{ MHz}$** 

Parameter	Symbol	Values			Unit	Note / Test Condition
		Min.	Typ.	Max.		
<b>Maximum power gain</b>					dB	
High linearity operation point	$G_{ms}$	–	23	–		$I_C = 50\text{ mA}$
Class A operation point	$G_{ms}$	–	23.5	–		$I_C = 90\text{ mA}$
<b>Transducer gain</b>					dB	$Z_S = Z_L = 50\ \Omega$
High linearity operation point	$S_{21}$	–	18.5	–		$I_C = 50\text{ mA}$
Class A operation point	$S_{21}$	–	19	–		$I_C = 90\text{ mA}$
<b>Minimum noise figure</b>					dB	$Z_S = Z_{opt}$
Minimum noise figure	$NF_{min}$	–	1.6	–		$I_C = 50\text{ mA}$
Associated gain	$G_{ass}$	–	23	–		$I_C = 50\text{ mA}$
<b>Linearity</b>					dBm	$Z_S = Z_L = 50\ \Omega$
1 dB gain compression point	$OP_{1dB}$	–	19	–		$I_C = 90\text{ mA}$
3rd order intercept point	$OIP3$	–	30.5	–		$I_C = 90\text{ mA}$

**Table 5-6 AC Characteristics,  $V_{CE} = 3\text{ V}$ ,  $f = 1.5\text{ GHz}$** 

Parameter	Symbol	Values			Unit	Note / Test Condition
		Min.	Typ.	Max.		
<b>Maximum power gain</b>					dB	
High linearity operation point	$G_{ma}$	–	18	–		$I_C = 50\text{ mA}$
Class A operation point	$G_{ma}$	–	18	–		$I_C = 90\text{ mA}$
<b>Transducer gain</b>					dB	$Z_S = Z_L = 50\ \Omega$
High linearity operation point	$S_{21}$	–	14	–		$I_C = 50\text{ mA}$
Class A operation point	$S_{21}$	–	14	–		$I_C = 90\text{ mA}$
<b>Minimum noise figure</b>					dB	$Z_S = Z_{opt}$
Minimum noise figure	$NF_{min}$	–	1.65	–		$I_C = 50\text{ mA}$
Associated gain	$G_{ass}$	–	17	–		$I_C = 50\text{ mA}$
<b>Linearity</b>					dBm	$Z_S = Z_L = 50\ \Omega$
1 dB gain compression point	$OP_{1dB}$	–	19	–		$I_C = 90\text{ mA}$
3rd order intercept point	$OIP3$	–	31	–		$I_C = 90\text{ mA}$

**Table 5-7 AC Characteristics,  $V_{CE} = 3\text{ V}$ ,  $f = 1.9\text{ GHz}$** 

Parameter	Symbol	Values			Unit	Note / Test Condition
		Min.	Typ.	Max.		
<b>Maximum power gain</b>					dB	
High linearity operation point	$G_{ma}$	–	15.5	–		$I_C = 50\text{ mA}$
Class A operation point	$G_{ma}$	–	15.5	–		$I_C = 90\text{ mA}$
<b>Transducer gain</b>					dB	$Z_S = Z_L = 50\ \Omega$
High linearity operation point	$S_{21}$	9.5	11.5	–		$I_C = 50\text{ mA}$
Class A operation point	$S_{21}$	–	11.5	–		$I_C = 90\text{ mA}$
<b>Minimum noise figure</b>					dB	$Z_S = Z_{opt}$
Minimum noise figure	$NF_{min}$	–	1.7	–		$I_C = 50\text{ mA}$
Associated gain	$G_{ass}$	–	14	–		$I_C = 50\text{ mA}$
<b>Linearity</b>					dBm	$Z_S = Z_L = 50\ \Omega$
1 dB gain compression point	$OP_{1dB}$	–	19	–		$I_C = 90\text{ mA}$
3rd order intercept point	$OIP3$	–	31	–		$I_C = 90\text{ mA}$

**Table 5-8 AC Characteristics,  $V_{CE} = 3\text{ V}$ ,  $f = 2.4\text{ GHz}$** 

Parameter	Symbol	Values			Unit	Note / Test Condition
		Min.	Typ.	Max.		
<b>Maximum power gain</b>					dB	
High linearity operation point	$G_{ma}$	–	13.5	–		$I_C = 50\text{ mA}$
Class A operation point	$G_{ma}$	–	13.5	–		$I_C = 90\text{ mA}$
<b>Transducer gain</b>					dB	$Z_S = Z_L = 50\ \Omega$
High linearity operation point	$S_{21}$	–	9.5	–		$I_C = 50\text{ mA}$
Class A operation point	$S_{21}$	–	9.5	–		$I_C = 90\text{ mA}$
<b>Minimum noise figure</b>					dB	$Z_S = Z_{opt}$
Minimum noise figure	$NF_{min}$	–	1.8	–		$I_C = 50\text{ mA}$
Associated gain	$G_{ass}$	–	12	–		$I_C = 50\text{ mA}$
<b>Linearity</b>					dBm	$Z_S = Z_L = 50\ \Omega$
1 dB gain compression point	$OP_{1dB}$	–	19	–		$I_C = 90\text{ mA}$
3rd order intercept point	$OIP3$	–	30	–		$I_C = 90\text{ mA}$

**Table 5-9 AC Characteristics,  $V_{CE} = 3\text{ V}$ ,  $f = 3.5\text{ GHz}$** 

Parameter	Symbol	Values			Unit	Note / Test Condition
		Min.	Typ.	Max.		
<b>Maximum power gain</b>					dB	
High linearity operation point	$G_{ma}$	–	10	–		$I_C = 50\text{ mA}$
Class A operation point	$G_{ma}$	–	10	–		$I_C = 90\text{ mA}$
<b>Transducer gain</b>					dB	$Z_S = Z_L = 50\ \Omega$
High linearity operation point	$S_{21}$	–	5.5	–		$I_C = 50\text{ mA}$
Class A operation point	$S_{21}$	–	6	–		$I_C = 90\text{ mA}$
<b>Minimum noise figure</b>					dB	$Z_S = Z_{opt}$
Minimum noise figure	$NF_{min}$	–	2.05	–		$I_C = 50\text{ mA}$
Associated gain	$G_{ass}$	–	9	–		$I_C = 50\text{ mA}$
<b>Linearity</b>					dBm	$Z_S = Z_L = 50\ \Omega$
1 dB gain compression point	$OP_{1dB}$	–	18.5	–		$I_C = 90\text{ mA}$
3rd order intercept point	$OIP3$	–	29.5	–		$I_C = 90\text{ mA}$

**Notes**

1. AC parameter limits verified by random sampling
2. In order to get the  $NF_{min}$  values stated in this chapter the test fixture losses have been subtracted from all measured result
3.  $OIP3$  value depends on termination of all intermodulation frequency components. Termination used for this measurement is  $50\ \Omega$  from 0.2 MHz to 12 GHz.

5.4 Characteristic DC Diagrams

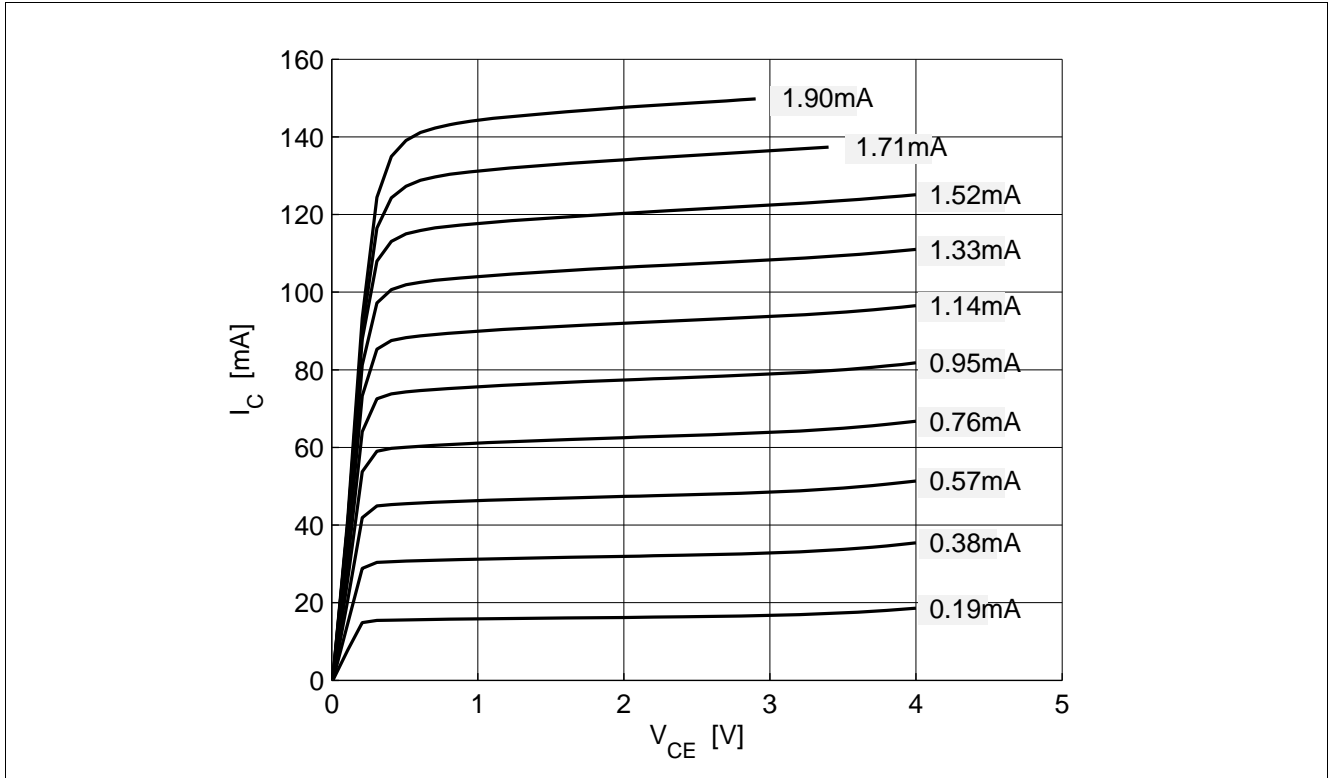

Figure 5-2 Collector Current vs. Collector Emitter Voltage  $I_C = f(V_{CE})$ ,  $I_B = \text{Parameter in mA}$

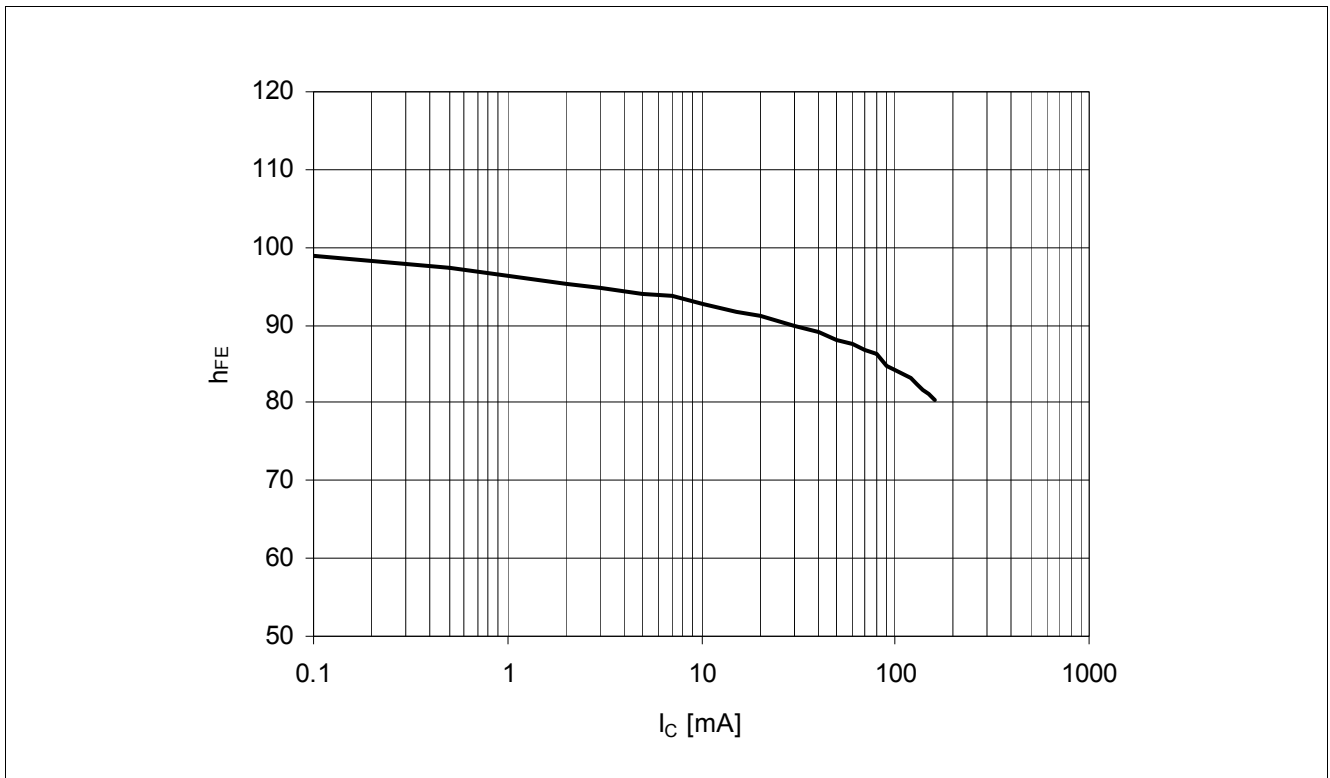

Figure 5-3 DC Current Gain  $h_{FE} = f(I_C)$ ,  $V_{CE} = 3 \text{ V}$



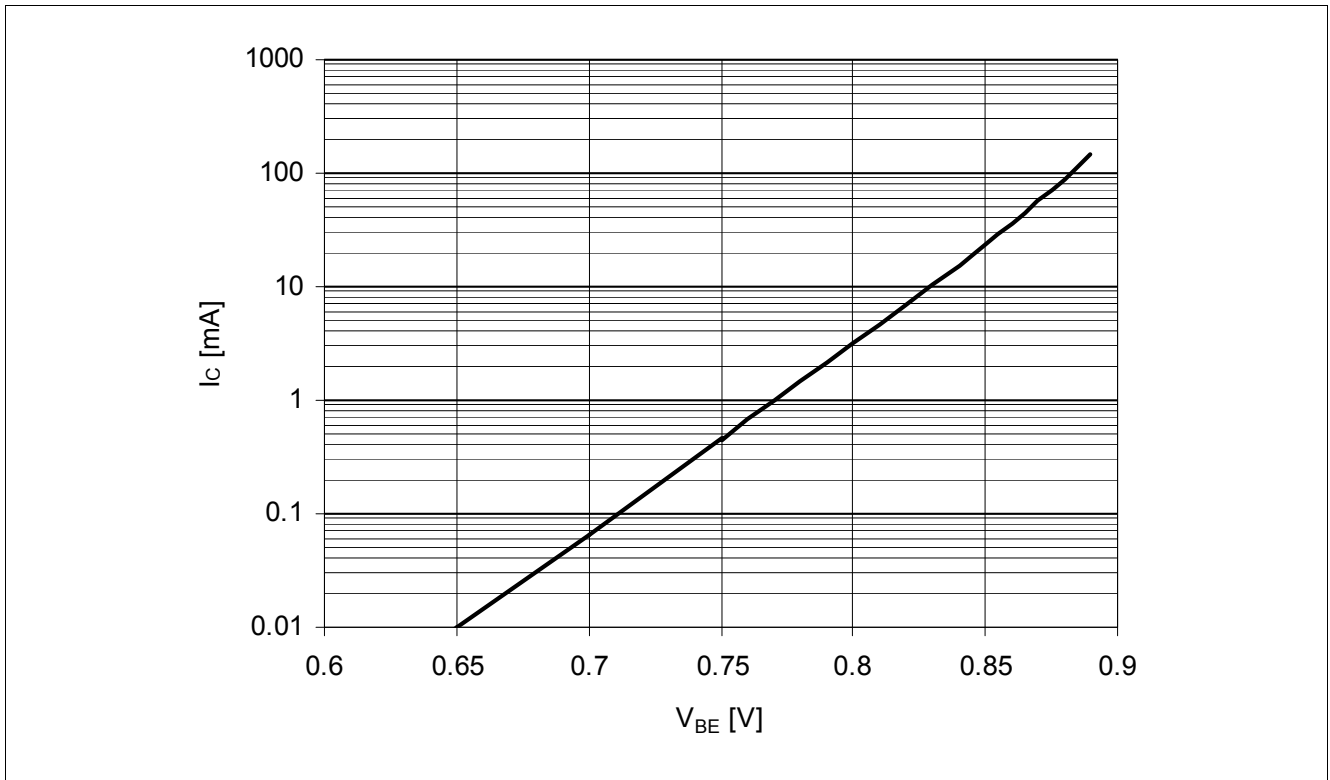

Figure 5-4 Collector Current vs. Base Emitter Voltage  $I_C = f(V_{BE})$ ,  $V_{CE} = 2\text{ V}$

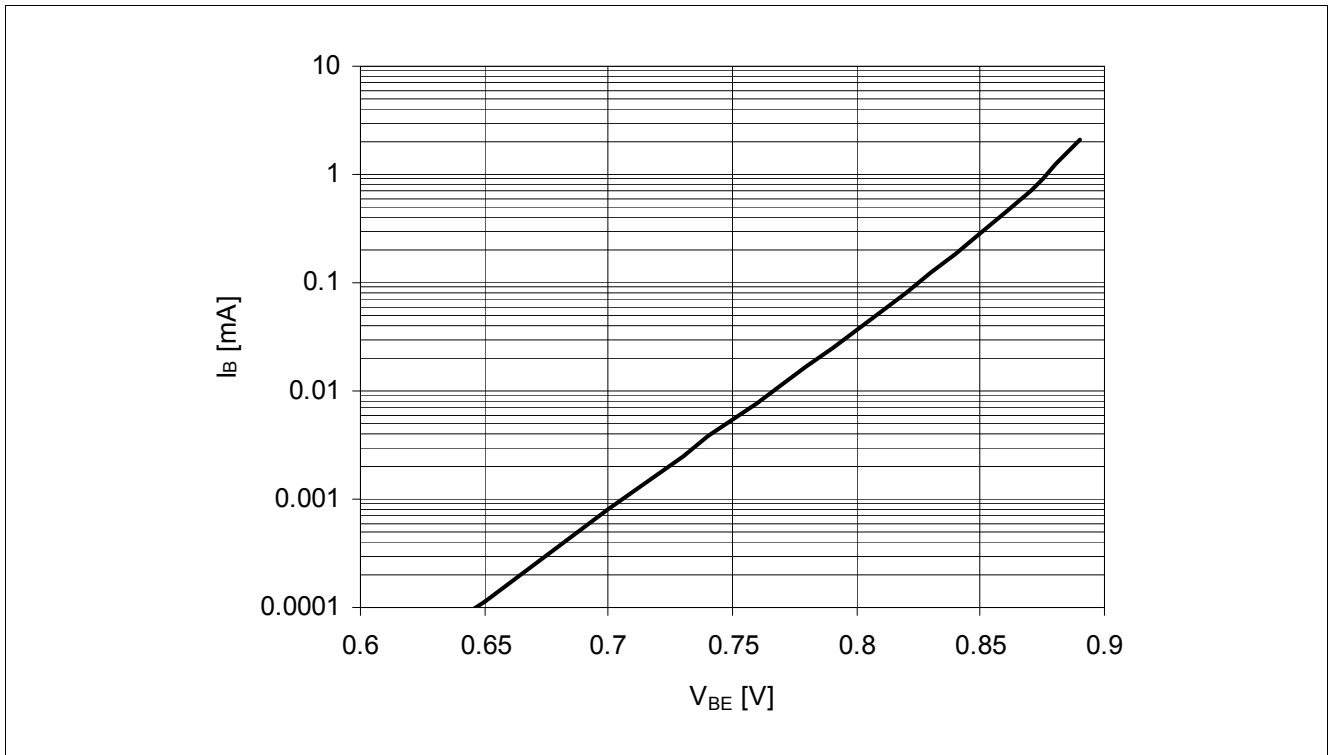

Figure 5-5 Base Current vs. Base Emitter Forward Voltage  $I_B = f(V_{BE})$ ,  $V_{CE} = 2\text{ V}$

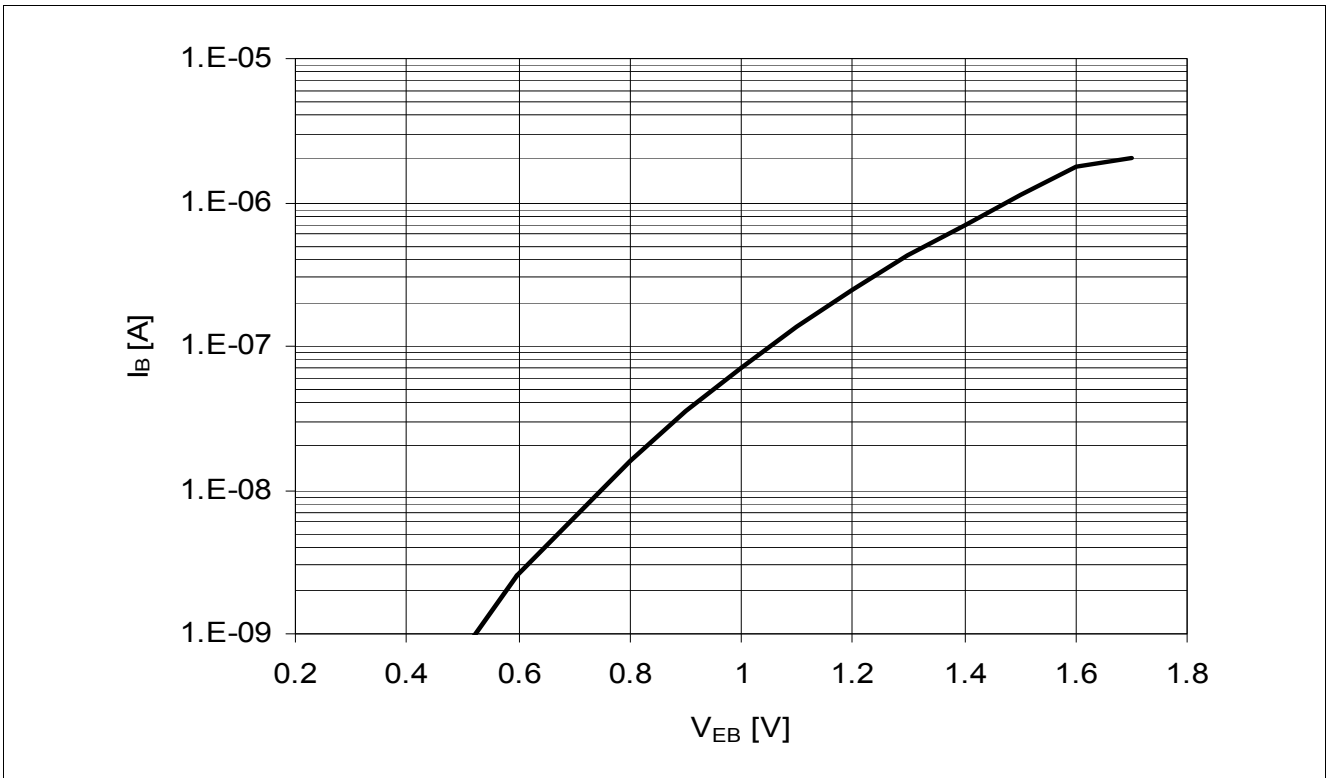

Figure 5-6 Base Current vs. Base Emitter Reverse Voltage  $I_B = f(V_{EB})$ ,  $V_{CE} = 2\text{ V}$

5.5 Characteristic AC Diagrams

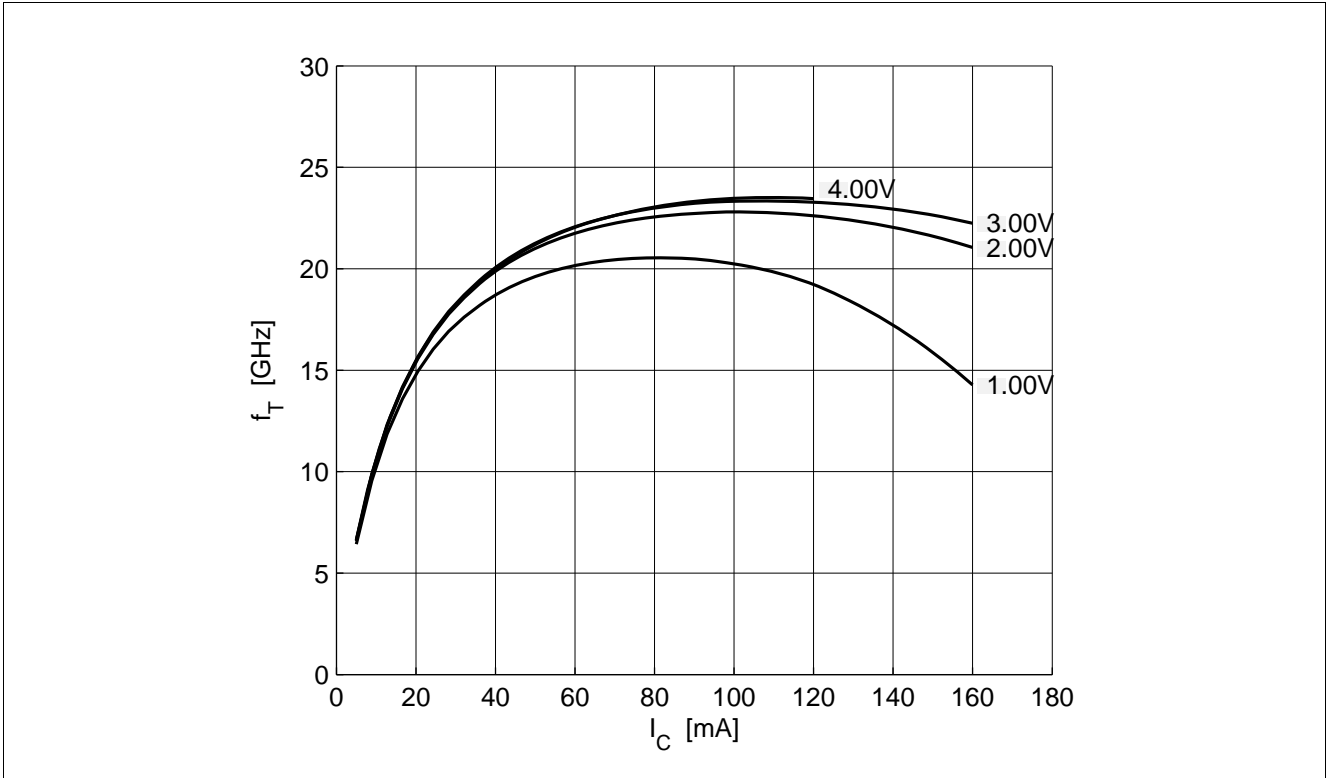

Figure 5-7 Transition Frequency  $f_T = f(I_C)$ ,  $f = 1 \text{ GHz}$ ,  $V_{CE} = \text{Parameter in V}$

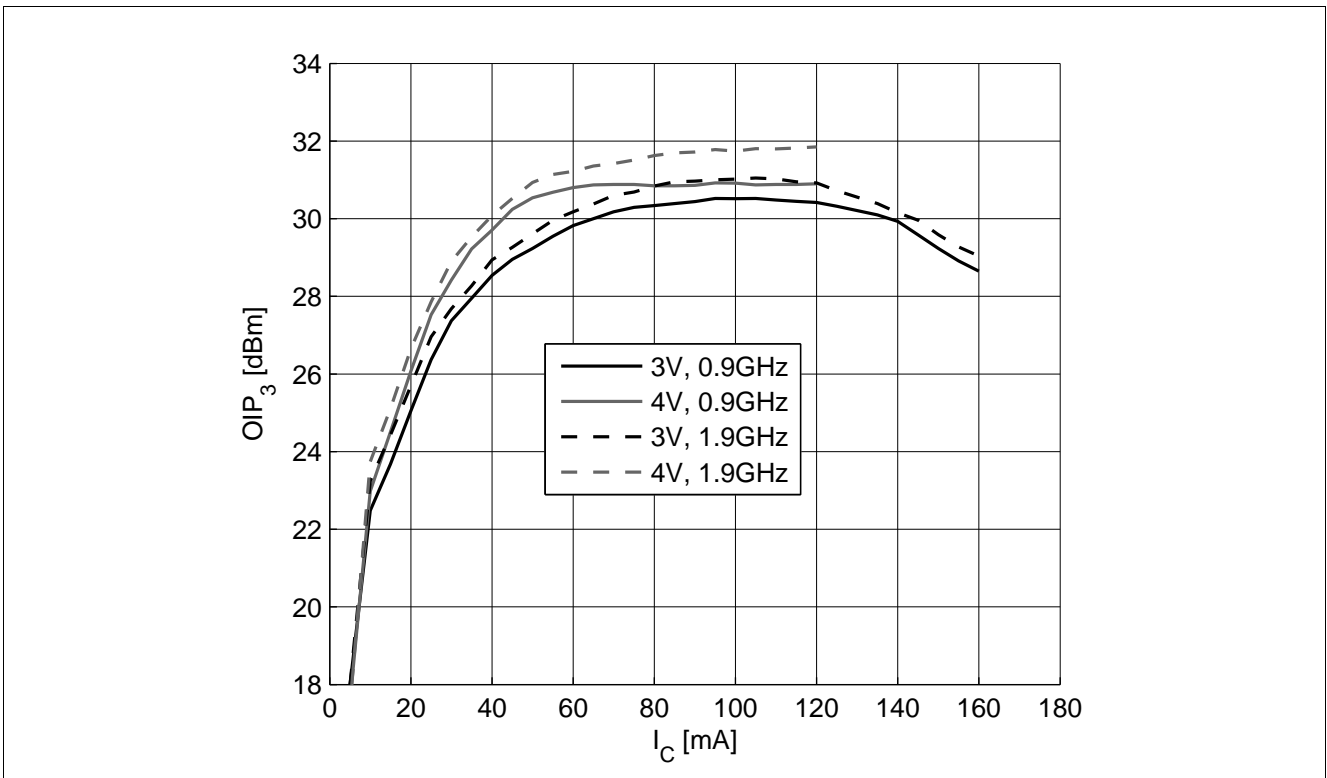

Figure 5-8 3rd Order Intercept Point  $OIP_3 = f(I_C)$ ,  $Z_S = Z_L = 50 \Omega$ ,  $V_{CE}, f = \text{Parameters}$

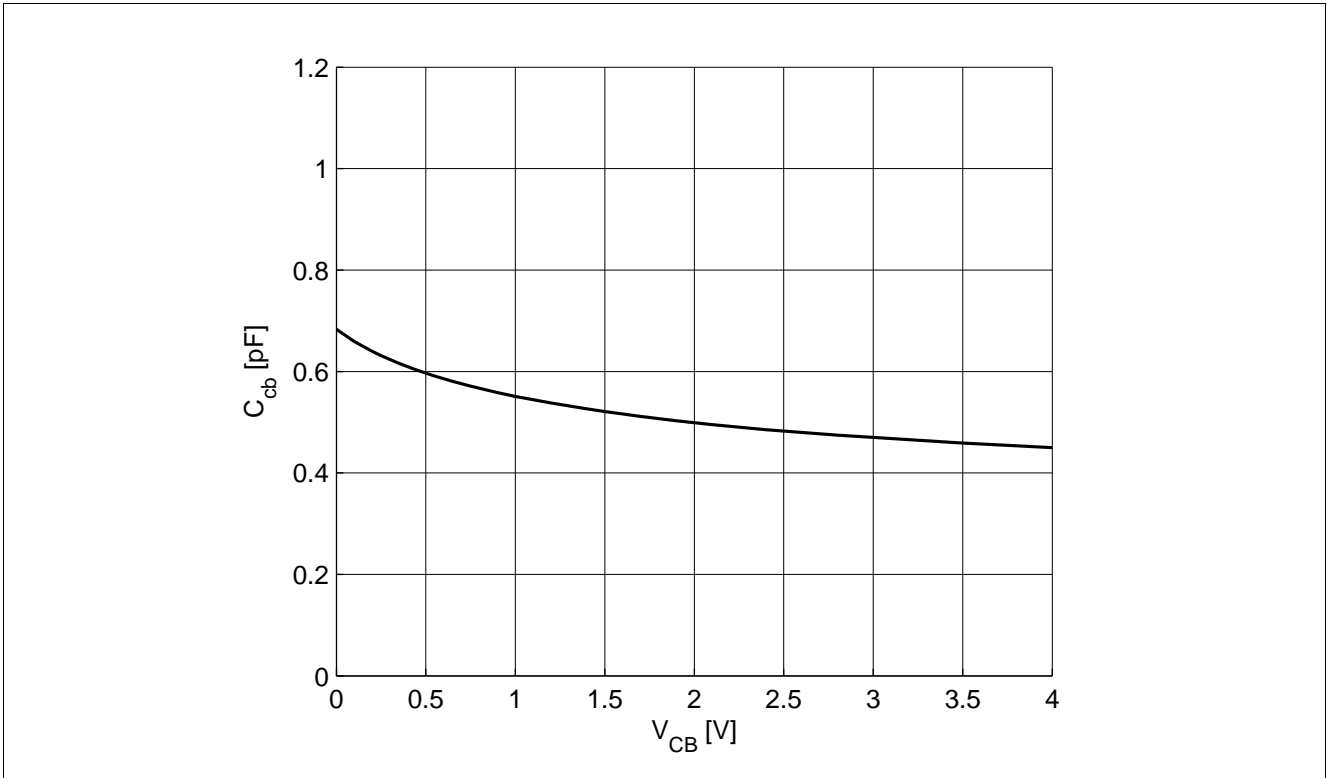

Figure 5-9 Collector Base Capacitance  $C_{CB} = f(V_{CB}), f = 1 \text{ MHz}$

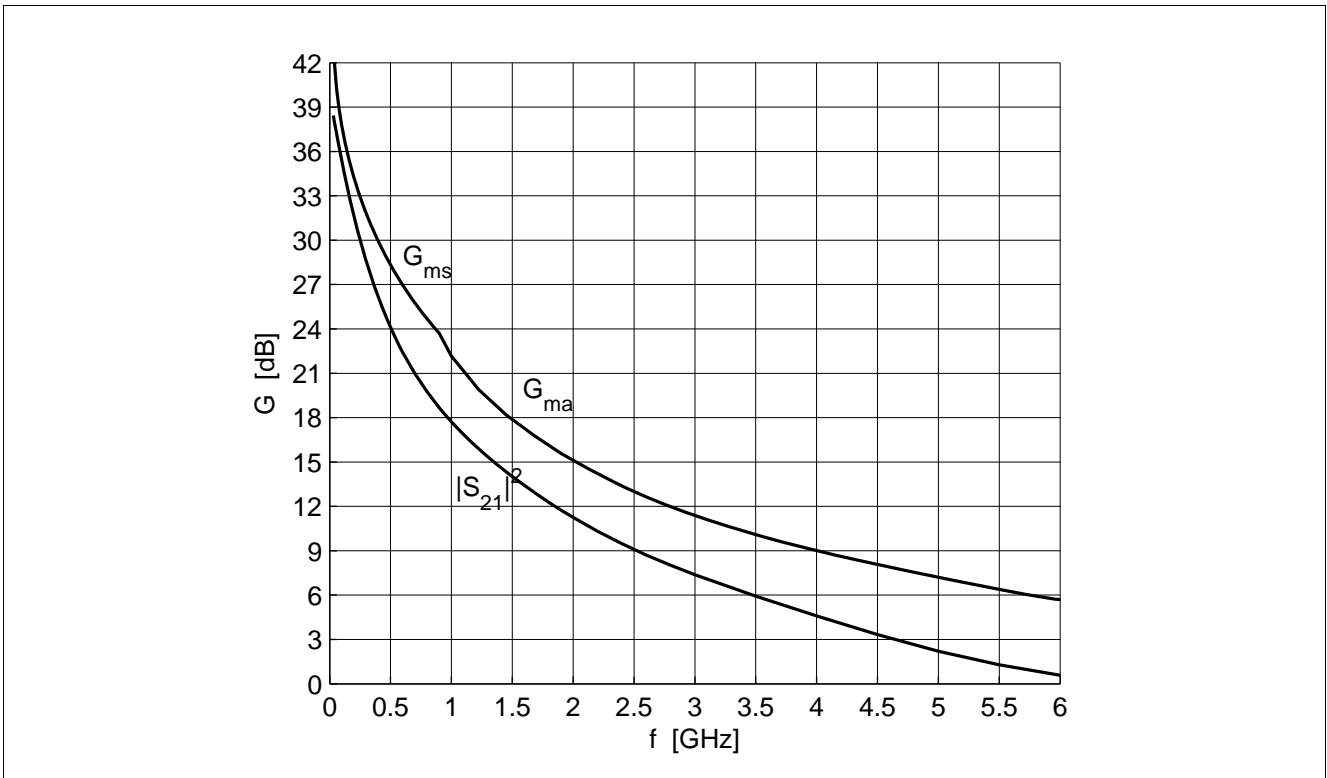

Figure 5-10 Gain  $G_{ma}, G_{ms}, |S_{21}|^2 = f(f), V_{CE} = 3 \text{ V}, I_C = 90 \text{ mA}$

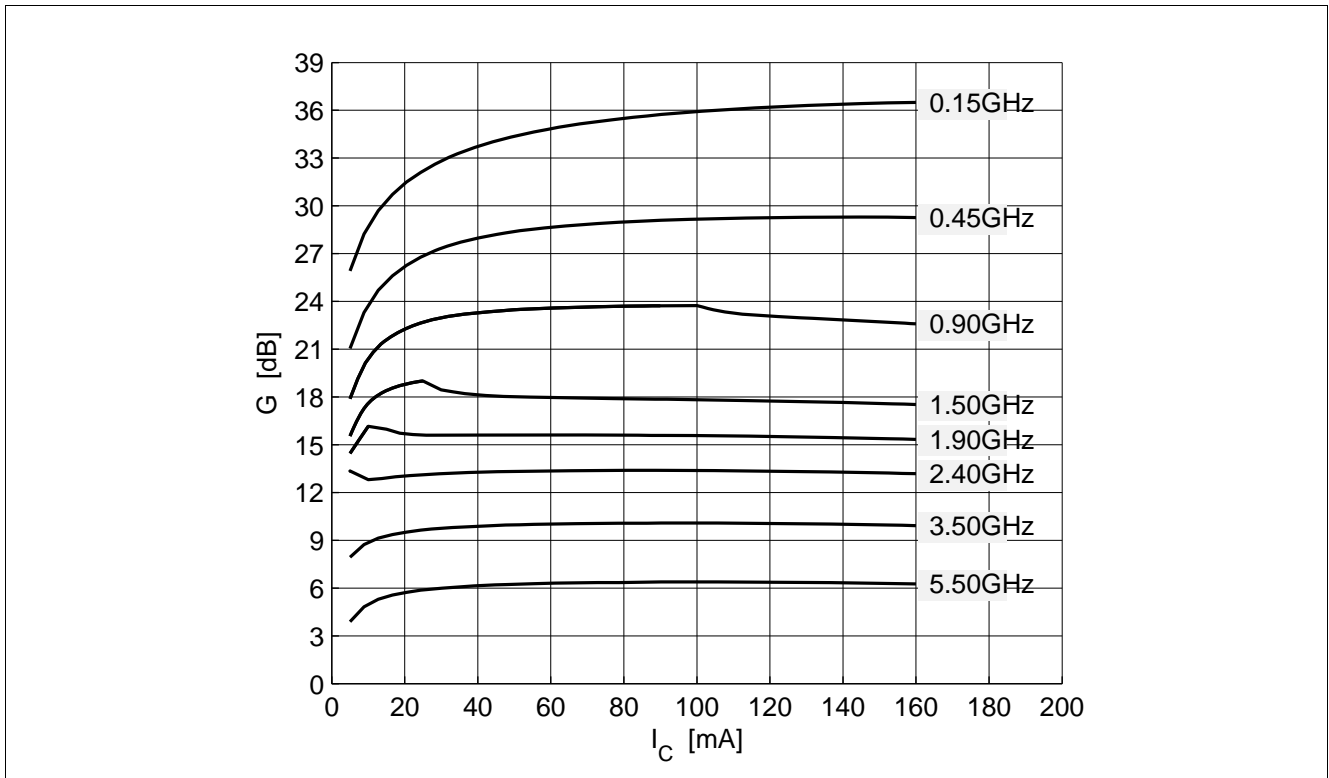

Figure 5-11 Maximum Power Gain  $G_{max} = f(I_C)$ ,  $V_{CE} = 3\text{ V}$ , = Parameter in GHz

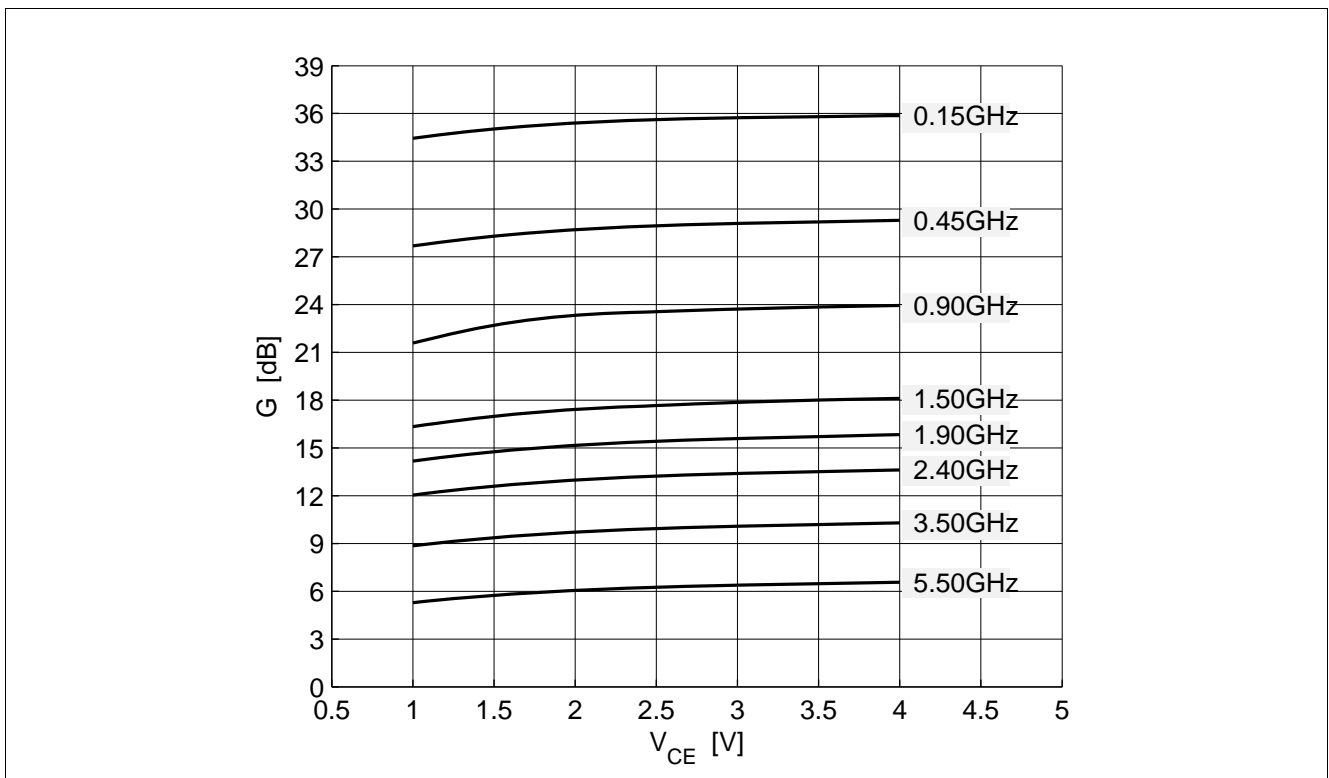

Figure 5-12 Maximum Power Gain  $G_{max} = f(V_{CE})$ ,  $I_C = 90\text{ mA}$ , = Parameter in GHz

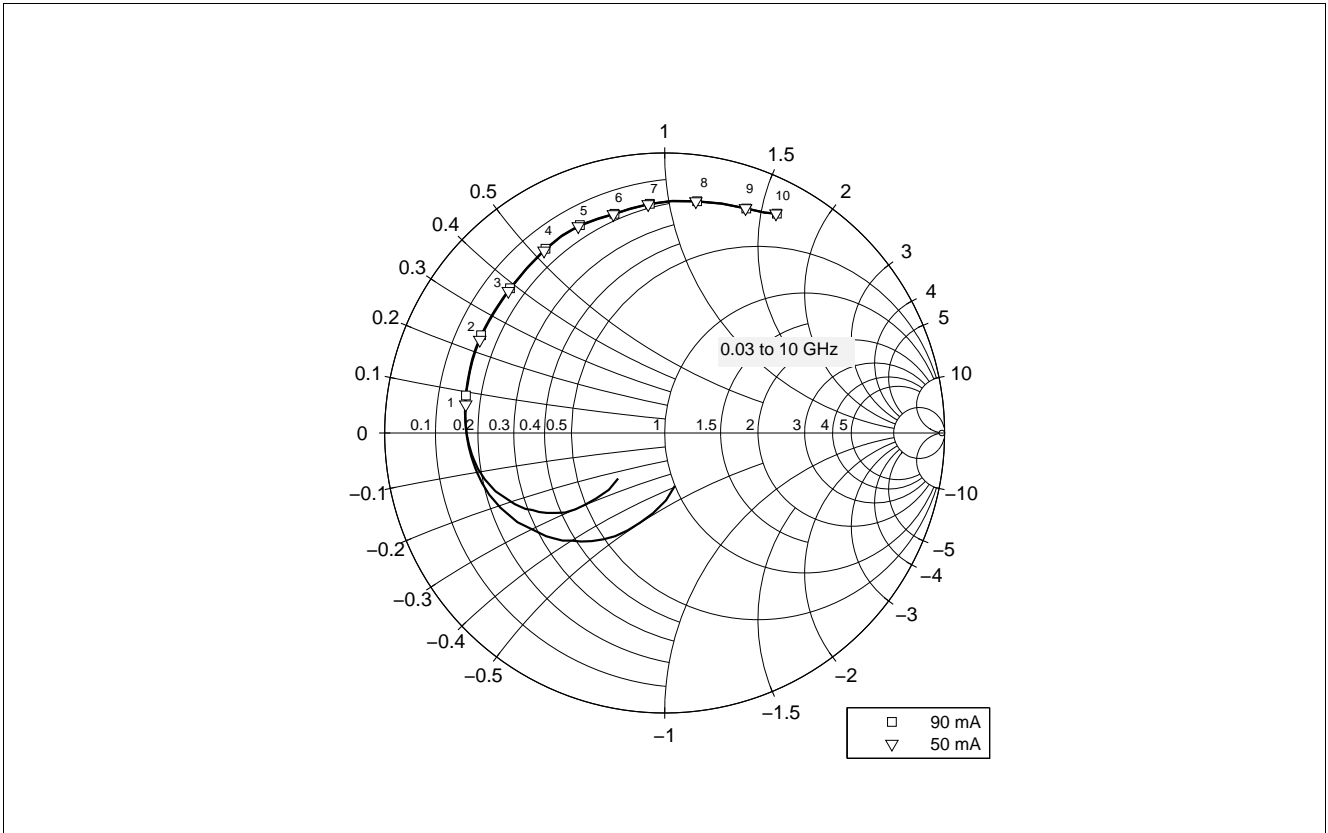

Figure 5-13 Input Matching  $S_{11} = f(f)$ ,  $V_{CE} = 3\text{ V}$ ,  $I_C = 50 / 90\text{ mA}$

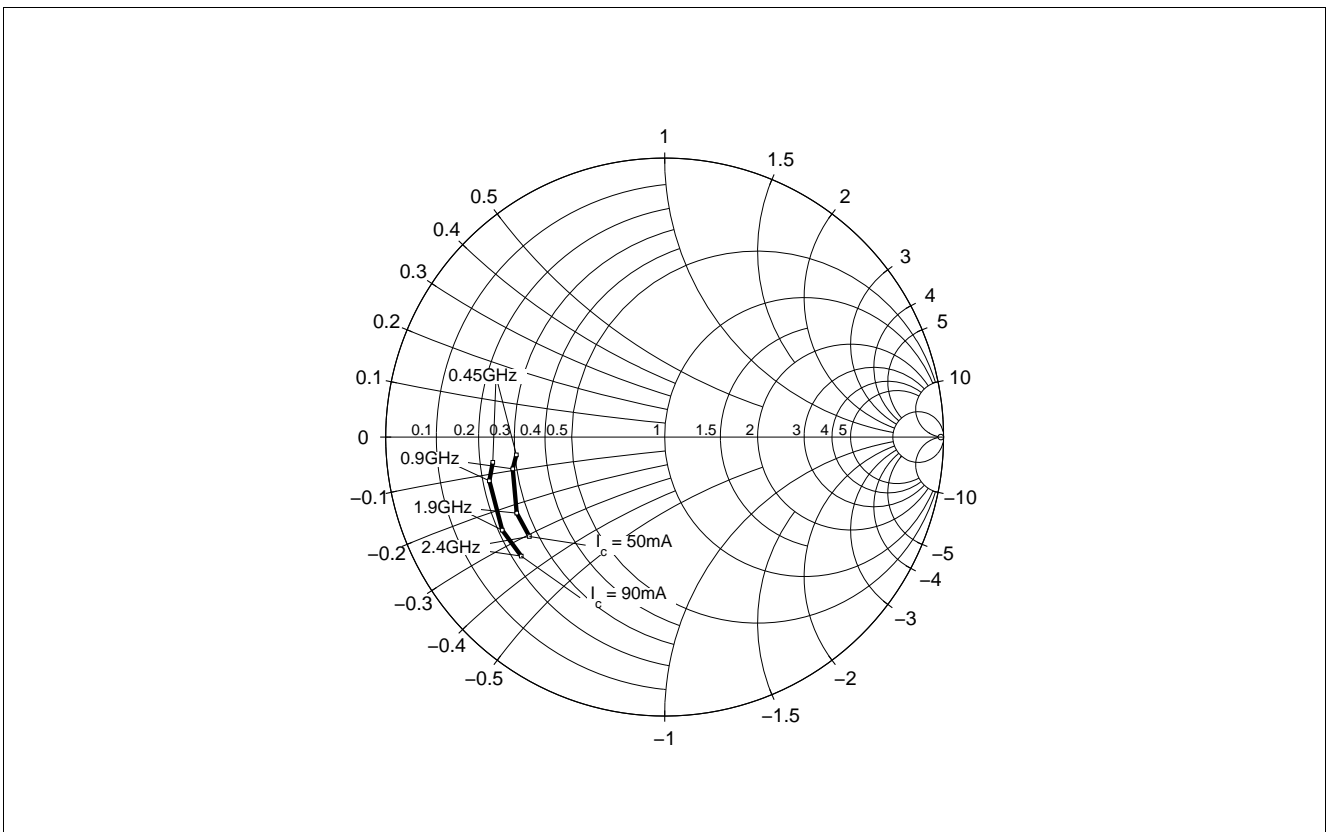

Figure 5-14 Source Impedance for Minimum Noise Figure  $= f(f)$ ,  $V_{CE} = 3\text{ V}$ ,  $I_C = 50 / 90\text{ mA}$

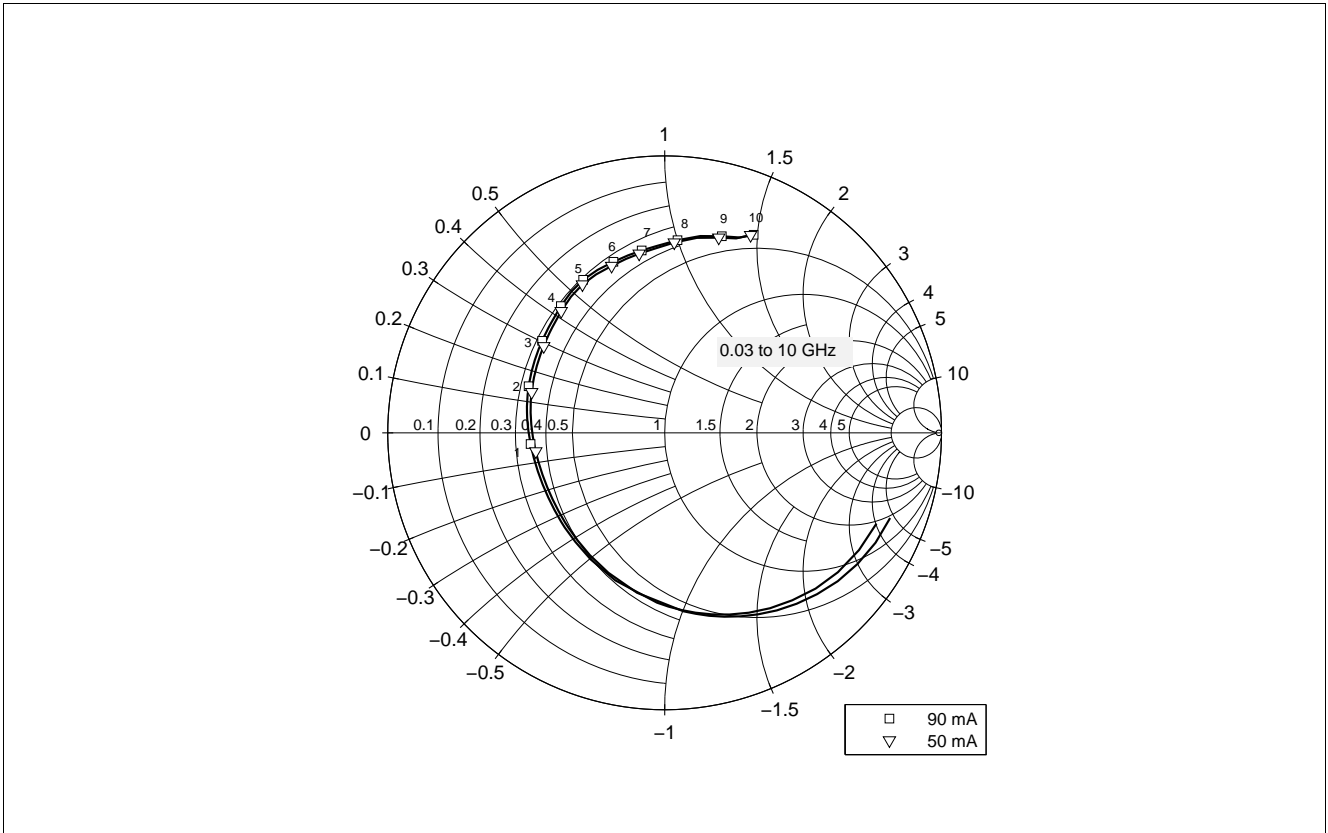

Figure 5-15 Output Matching  $S_{22} = f(f)$ ,  $V_{CE} = 3 \text{ V}$ ,  $I_C = 50 / 90 \text{ mA}$

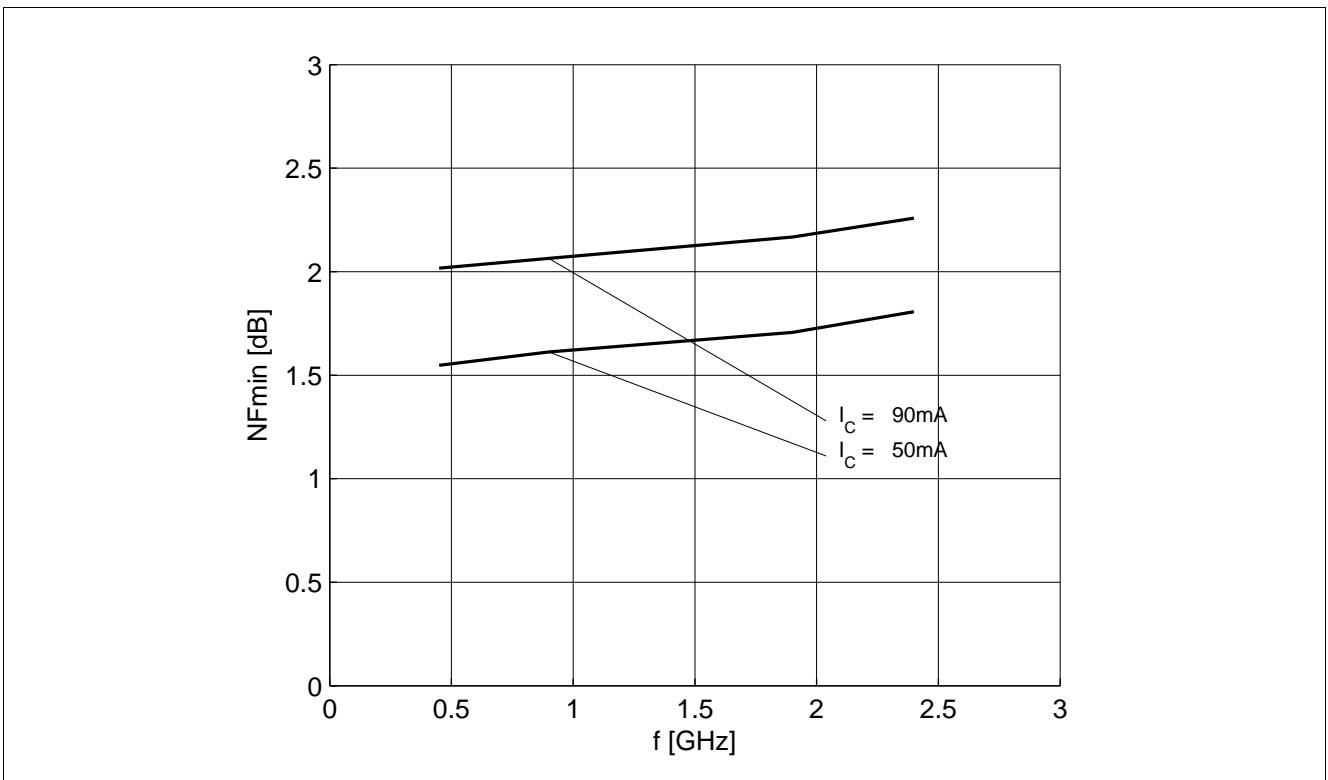

Figure 5-16 Noise Figure  $NF_{min} = f(f)$ ,  $V_{CE} = 3 \text{ V}$ ,  $I_C = 50 / 90 \text{ mA}$ ,  $Z_S = Z_{opt}$

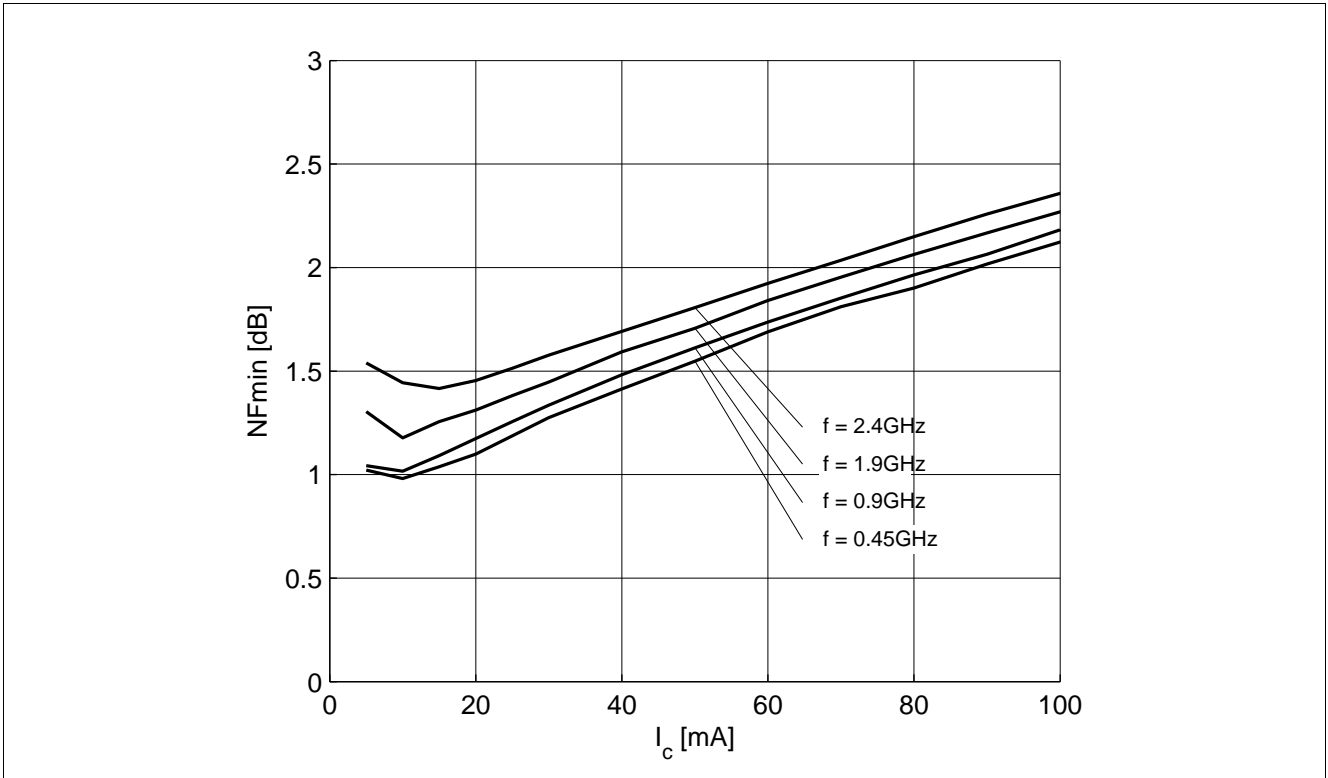

Figure 5-17 Noise Figure  $NF_{min} = f(I_C)$ ,  $V_{CE} = 3\text{ V}$ ,  $Z_S = Z_{opt}$  Parameter in GHz

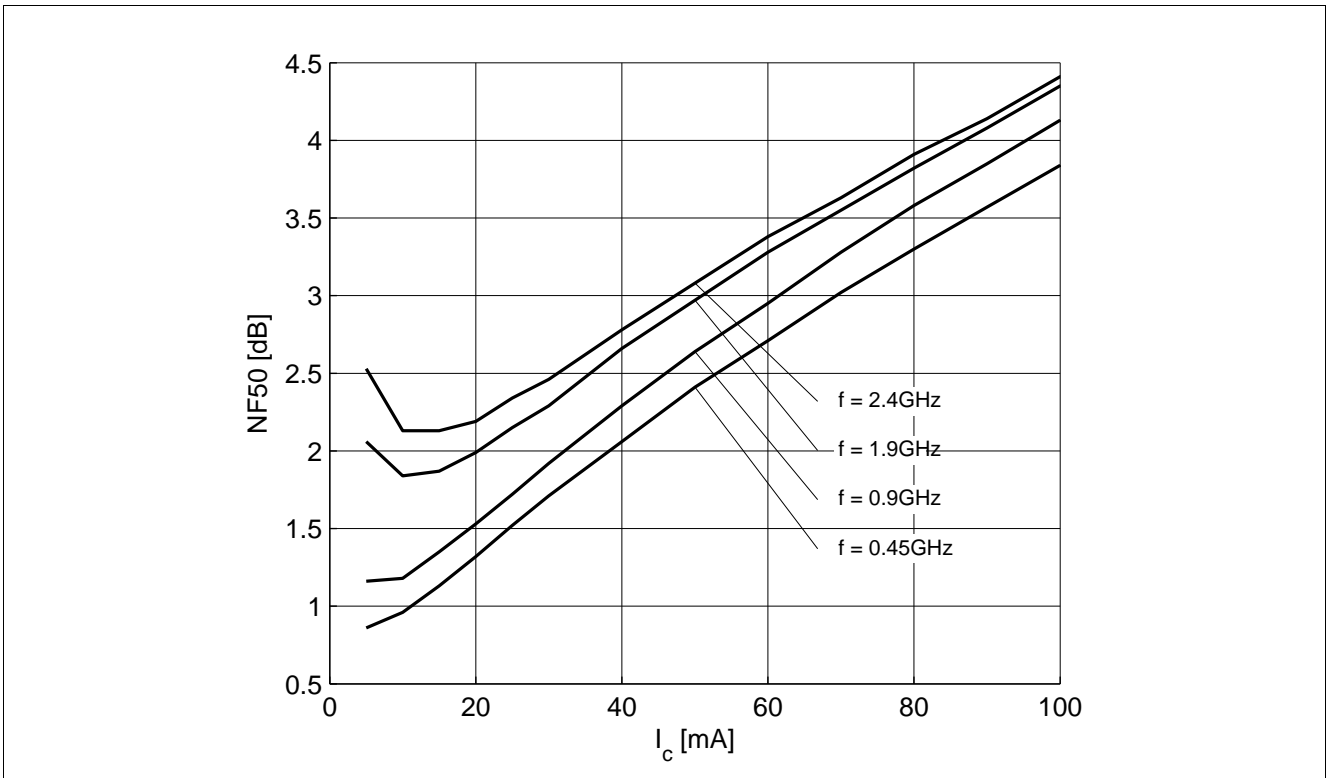

Figure 5-18 Noise Figure  $NF_{50} = f(I_C)$ ,  $V_{CE} = 3\text{ V}$ ,  $Z_S = 50\ \Omega$  Parameter in GHz



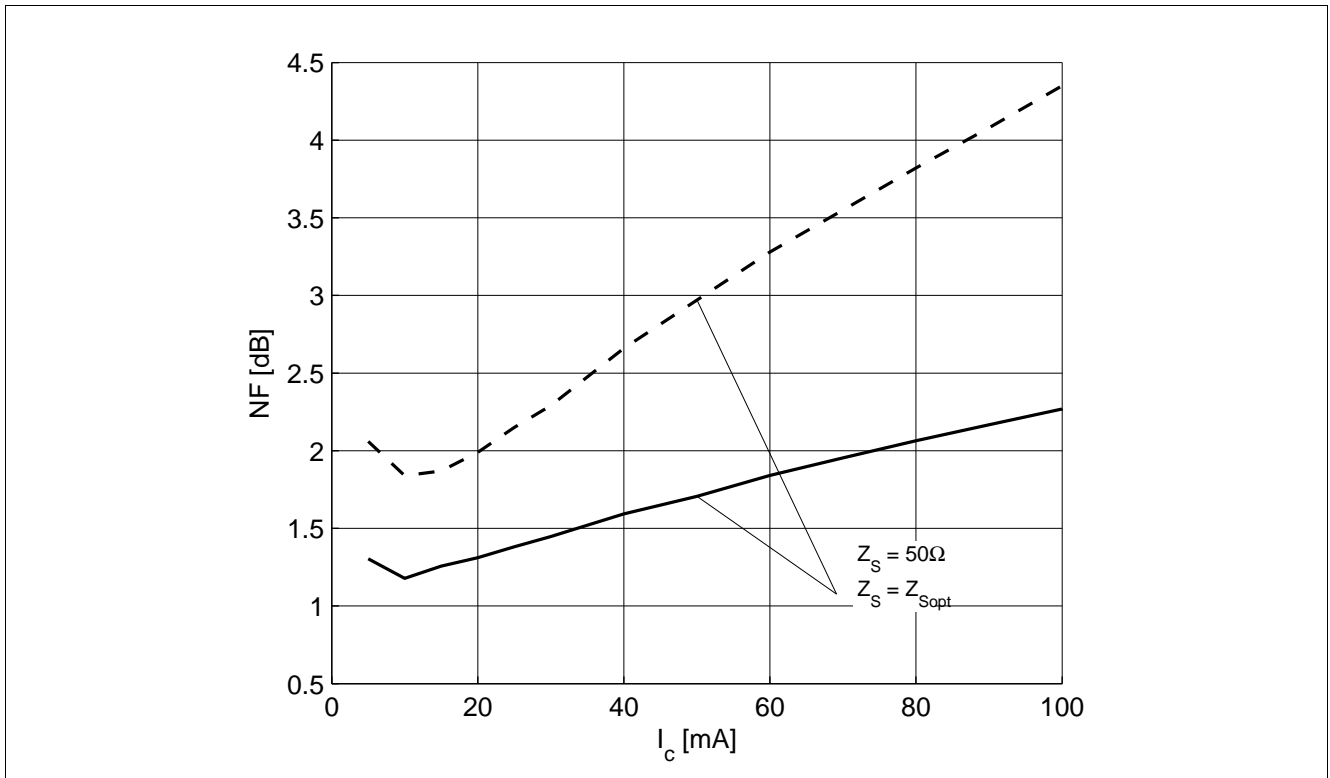

Figure 5-19 Comparison Noise Figure  $NF_{50} / NF_{min} = f(I_C)$ ,  $V_{CE} = 3\text{ V}$ ,  $f = 1.9\text{ GHz}$

Note: The curves shown in this chapter have been generated using typical devices but shall not be considered as a guarantee that all devices have identical characteristic curves.  $T_A = 25\text{ }^\circ\text{C}$ .

## 6 Simulation Data

For the SPICE Gummel Poon (GP) model as well as for the S-parameters (including noise parameters) please refer to our internet website: [www.infineon.com/rf.models](http://www.infineon.com/rf.models). Please consult our website and download the latest versions before actually starting your design.

You find the BFP450 SPICE GP model in the internet in MWO- and ADS-format, which you can import into these circuit simulation tools very quickly and conveniently. The model already contains the package parasitics and is ready to use for DC- and high frequency simulations. The terminals of the model circuit correspond to the pin configuration of the device.

The model parameters have been extracted and verified up to 10 GHz using typical devices. The BFP450 SPICE GP model reflects the typical DC- and RF-performance within the limitations which are given by the SPICE GP model itself.

## 7 Package Information SOT343

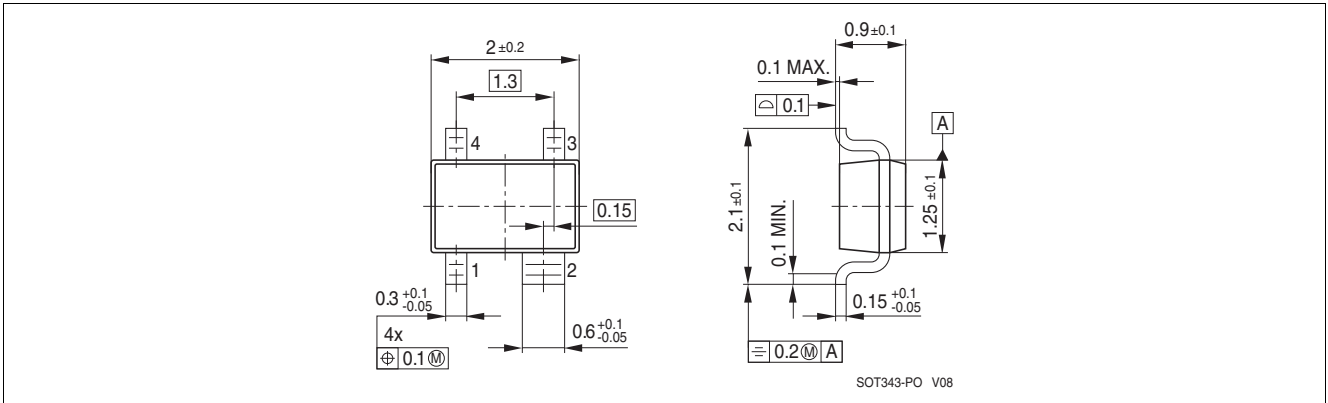

Figure 7-1 Package Outline

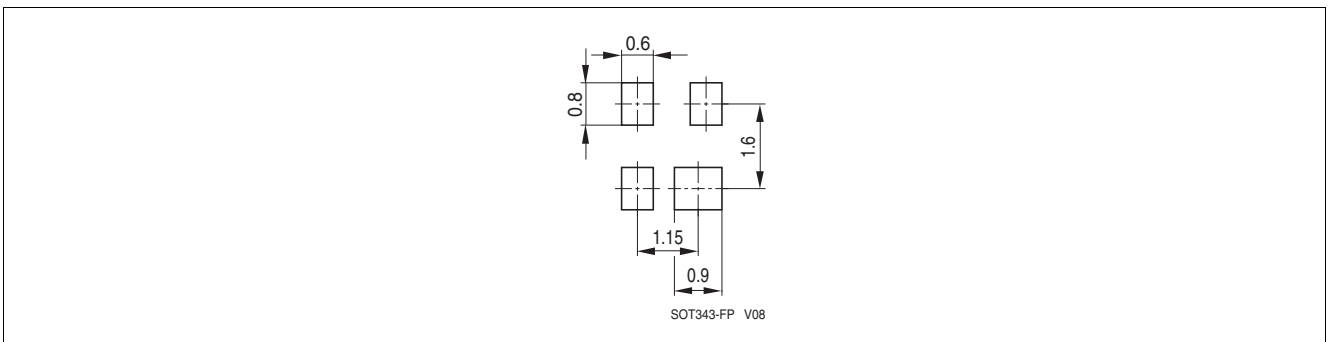

Figure 7-2 Package Footprint

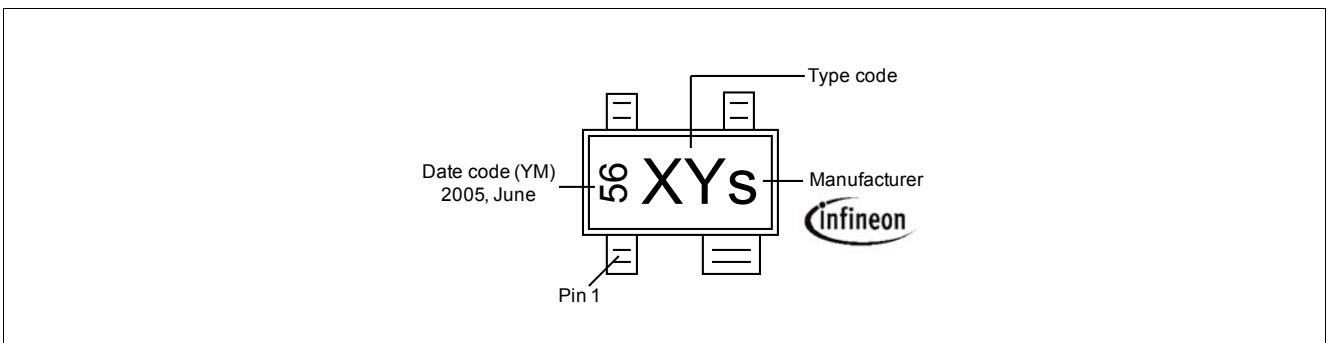

Figure 7-3 Marking Description (Marking BFP450: ANs)

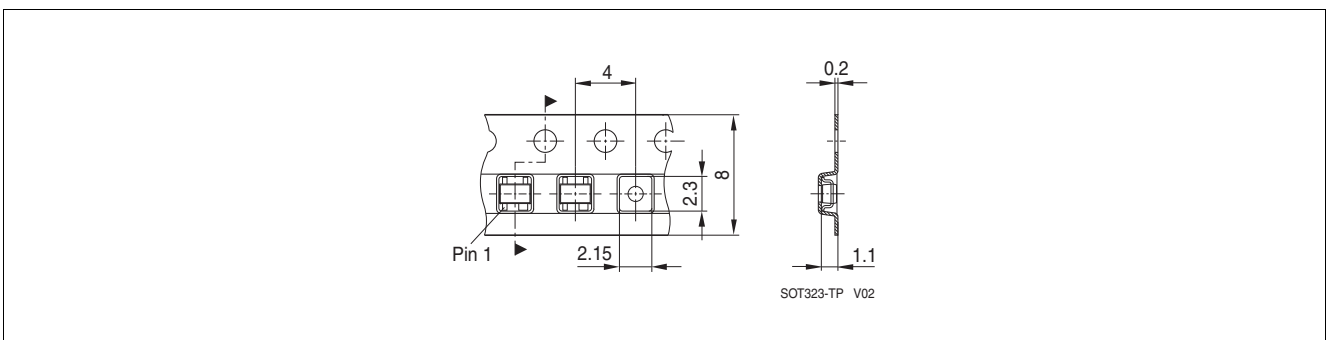

Figure 7-4 Tape Dimensions

[www.infineon.com](http://www.infineon.com)

Published by Infineon Technologies AG

## Данный компонент на территории Российской Федерации

### Вы можете приобрести в компании MosChip.

Для оперативного оформления запроса Вам необходимо перейти по данной ссылке:

<http://moschip.ru/get-element>

Вы можете разместить у нас заказ для любого Вашего проекта, будь то серийное производство или разработка единичного прибора.

В нашем ассортименте представлены ведущие мировые производители активных и пассивных электронных компонентов.

Нашей специализацией является поставка электронной компонентной базы двойного назначения, продукции таких производителей как XILINX, Intel (ex.ALTERA), Vicor, Microchip, Texas Instruments, Analog Devices, Mini-Circuits, Amphenol, Glenair.

Сотрудничество с глобальными дистрибьюторами электронных компонентов, предоставляет возможность заказывать и получать с международных складов практически любой перечень компонентов в оптимальные для Вас сроки.

На всех этапах разработки и производства наши партнеры могут получить квалифицированную поддержку опытных инженеров.

Система менеджмента качества компании отвечает требованиям в соответствии с ГОСТ Р ИСО 9001, ГОСТ РВ 0015-002 и ЭС РД 009

### Офис по работе с юридическими лицами:

105318, г.Москва, ул.Щербаковская д.3, офис 1107, 1118, ДЦ «Щербаковский»

Телефон: +7 495 668-12-70 (многоканальный)

Факс: +7 495 668-12-70 (доб.304)

E-mail: [info@moschip.ru](mailto:info@moschip.ru)

Skype отдела продаж:

moschip.ru

moschip.ru\_4

moschip.ru\_6

moschip.ru\_9