

DISTINCTIVE CHARACTERISTICS

- High definition, contrast and resolution of 96RGB x 64 pixels in compact screen and minimal frame
- Range of 65,536 colors in 16 bit mode
- Operating life of 50,000 hours minimum
- Maximum use of display lens with ultra-thin frame provides full screen capacity
- Multiple units easily combine to form one screen, offering flexibility in size and layout
- Smooth, silent operation with short stroke of 0.07" lends to tactile feedback unparalleled to touch panels
- Same outer dimensions of switch and footprint, enabling ease of replacement with current switches
- Operated by commands and data supplied via serial communications (SPI)
- Incorporates bitmap display function
- Low energy consumption
- Dust tight construction
- Snap-in standoff for easy, secure mounting and alignment; aids in prevention of dislodging during wave soldering

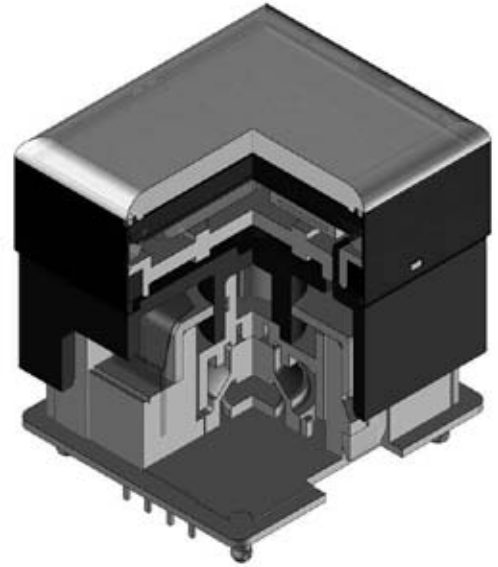

Viewing area: 21.28mm x 18.74mm (horizontal x vertical)

Long life of one million actuations minimum

Highly reliable gold plated twin contacts

Epoxy sealed straight PC terminals

Actual Size

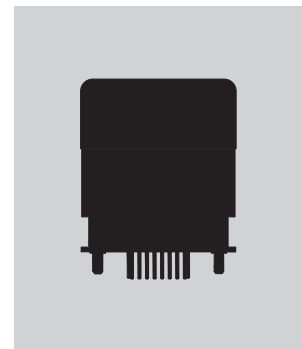

PART NUMBER & DESCRIPTION



Part Number	Switch Description	OLED	Pixel Format
ISF15ACP4	SPST, Momentary ON Gold Contacts Straight PC Terminals	Color OLED Display Module 65,536 Colors	96RGB x 64 Pixels Horizontal x Vertical

SWITCH SPECIFICATIONS

Circuit	SPST normally open
Contact Position	Leave actuator: ① – ② OFF Push actuator: ① – ② ON
Electrical Capacity (Resistive Load)	100mA @ 12V DC (resistive circuit)
Contact Resistance	200 milliohms maximum @ 20mV 10mA
Insulation Resistance	100 megohms minimum @ 100V DC
Dielectric Strength	125V AC for 1 minute minimum
Mechanical Endurance	1,000,000 operations minimum
Electrical Endurance	1,000,000 operations minimum
Operating Force	2.0 ± 0.5 Newtons
Total Travel	1.8mm (0.07")

OLED SPECIFICATIONS

Characteristics of Display

Display Device	Color OLED display module
Display Mode	Passive matrix
Viewing Area	21.28mm x 18.74mm (horizontal x vertical)
Pixel Format	96RGB x 64 pixels (horizontal x vertical)
Pixel Size	0.222mm x 0.293mm (horizontal x vertical)
Interface	Serial (SPI) interface
Number of Colors	65,536 Colors (16bit: R 5bit/G 6bit/B 5bit) or 256 Colors (8bit: R 2bit/G 3bit/B 3bit)
Operating Temperature Range	-20°C ~ +70°C (-4°F ~ +158°F)
Storage Temperature Range	-30°C ~ +80°C (-22°F ~ +176°F)
Operating Life (Display)	50,000 hours @ 100cd/m ² (based on 40% pixels ON; Ta = 77°F)

Absolute Maximum Ratings

Items	Symbols	Ratings
Supply Voltage for Logic/Interface	V _{DD}	-0.3V to +4.0V
Supply Voltage for Drive	V _{CC}	-0.0V to +19.0V
Input Voltage	V _I	-0.3V to V _{DD} +0.3V

Current Consumption

(Temperature at 25°C, V_{DD} = 2.8V, V_{CC} = 15.0V)

Items	Symbols	Min	Typical	Max
All-Pixels-On Mode *Drive System Power Current	I _{CC1}	—	11.0mA	13.2mA
All-Pixels-On Mode *Logic/IF System Power Current	I _{DD1}	—	0.17mA	0.20mA
Sleep Mode **Drive System Power Current	I _{CC2}	—	—	10μA
Sleep Mode **Logic/IF System Power Current	I _{DD2}	—	—	10μA

* All pixels shall be turned on with the maximum level gray scale
** All pixels shall be turned off (while chip is operating)

Recommended Operating Conditions

Items	Symbols	Minimum	Typical	Maximum
Supply Voltage for Logic/Interface	V _{DD}	2.4V	2.8V	3.5V
Supply Voltage for Drive	V _{CC}	14.0V	15.0V	16.0V
Input High Level Voltage	V _{IH}	0.8 x V _{DD}	—	—
Input Low Level Voltage	V _{IL}	—	—	0.2 x V _{DD}

Optical Characteristics (Temperature at 25°C, Initial Value: 87 x 0F)

Items	Min	Typical	Max	Unit	Remarks
Luminosity	80	105	130	cd/m ²	White (All pixels on)
White Color Coordinate	(x)	0.26	0.30	0.34	—
	(y)	0.31	0.36	0.41	—
Red Color Coordinate	(x)	0.62	0.66	0.70	—
	(y)	0.30	0.34	0.38	—
Green Color Coordinate	(x)	0.24	0.29	0.33	—
	(y)	0.59	0.63	0.67	—
Blue Color Coordinate	(x)	0.10	0.15	0.19	—
	(y)	0.10	0.17	0.23	—
Contrast Ratio	100	—	—	—	—

BLOCK DIAGRAM & PIN CONFIGURATIONS



ISF15ACP4

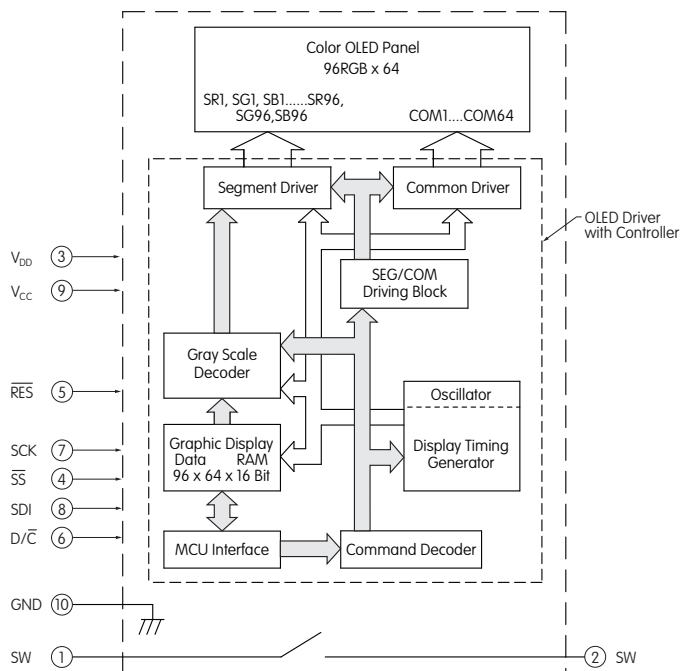

Pin No.	Symbol	Name	Function
①	SW	Terminal of Switch	Normally open
②	SW	Terminal of Switch	Normally open
③	V _{DD}	Power	Power source for logic circuit
④	SS	Slave Select	Slave select for SPI. This line is active low.
⑤	RES	Reset	Reset signal input. When pin is low, initialization of chip is executed.
⑥	D/C	Data/Command	Data/Command Control. When pin is pulled low, data will be interpreted as Command; when pulled high, data will be interpreted as Data.
⑦	SCK	Serial Clock	Clock line for SPI that synchronizes command and data
⑧	SDI	Serial Data In	Data input line for SPI
⑨	V _{CC}	Power	Power source for drive circuit
⑩	GND	Ground	Connect to Ground

TYPICAL SWITCH DIMENSIONS

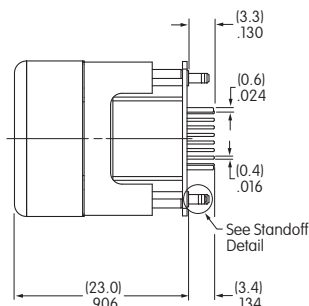
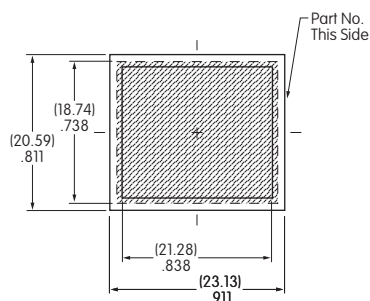

Terminal numbers are not on the switch.

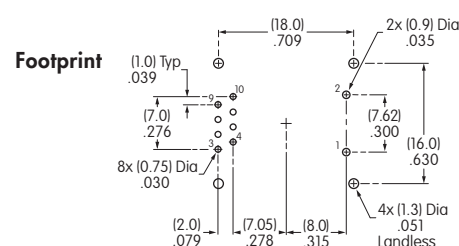
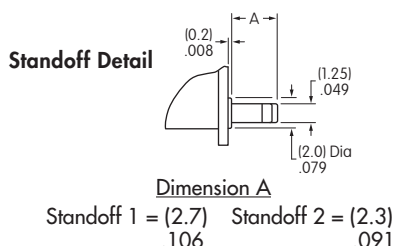
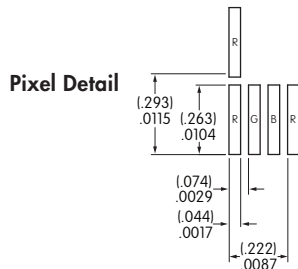
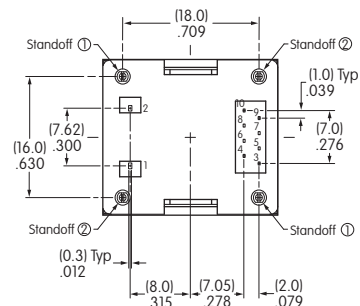

TIMING SPECIFICATIONS

AC Characteristics (Temperature at 25°C), $V_{DD} = 2.4V \sim 3.5V$

Items	Symbols	Minimum	Typical	Maximum
Clock Cycle Time	t_{cycle}	150ns	—	—
D/ \bar{C} Setup Time	t_{AS}	40ns	—	—
D/ \bar{C} Hold Time	t_{AH}	40ns	—	—
\bar{SS} Setup Time	t_{CSS}	75ns	—	—
\bar{SS} Hold Time	t_{CSH}	60ns	—	—
Write Data Setup Time	t_{DSW}	40ns	—	—
Write Data Hold Time	t_{DHW}	40ns	—	—
SCK Low Time	t_{CLKL}	75ns	—	—
SCK High Time	t_{CLKH}	75ns	—	—
SCK Rise Time	t_R	—	—	15ns
SCK Fall Time	t_F	—	—	15ns

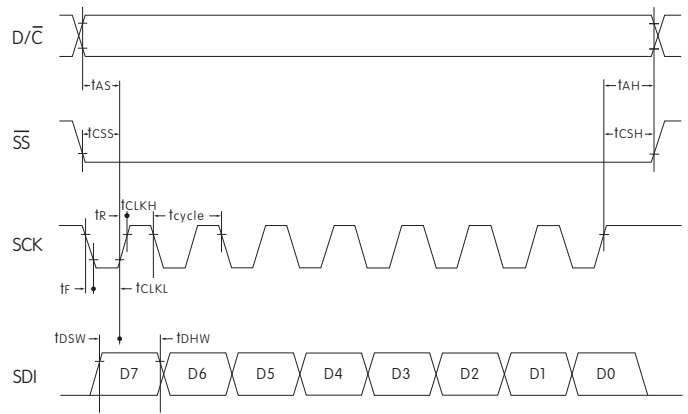

STATE TRANSITION

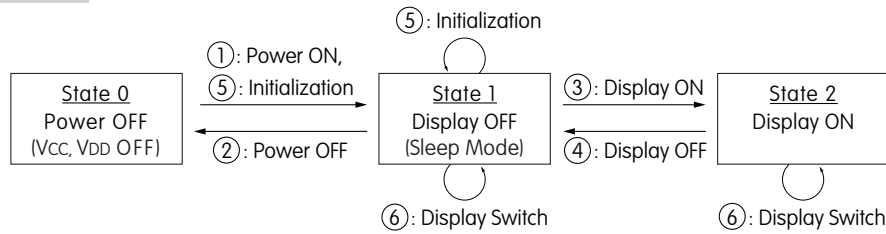

State Number	State	Display	Sleep	V_{CC}	V_{DD}	Changing the Display
0	Power OFF	OFF	—	OFF	OFF	Disable
1	Display OFF	OFF	ON	ON	ON	Enable
2	Display ON	ON	OFF	ON	ON	Enable

State Transition	Transition	Index
①	Power ON	Refer to "Power ON/OFF Sequence"
②	Power OFF	
③	Display ON	
④	Display OFF	
⑤	Initialization	Initialize Setting of Command/Data
⑥	Image Rewriting	Send Display Data
	Display Settings	Dimmer, Scroll, etc.

Power ON/OFF Sequence

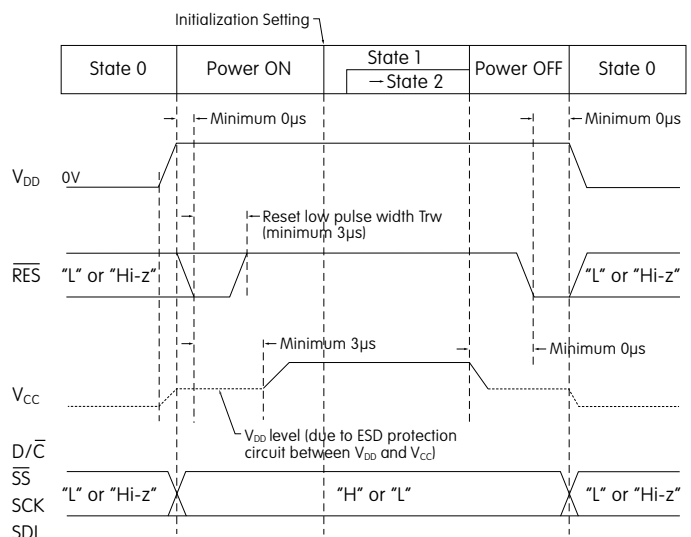

PRECAUTIONS FOR HANDLING & STORAGE OF OLED DEVICES

Handling



1. The IS Series OLED devices are electrostatic sensitive. To avoid damage to IC, do not touch terminals unless properly isolated from static electricity.
2. Signal input under conditions not recommended may cause damage to the OLED unit or deterioration of the display. Follow directions regarding supply sequences of power and signal voltages.
3. If the OLED panel is broken, avoid touching the contents. Wash off any contact to the skin or clothing.
4. Limit operating force to switch keytop to 100.0N maximum, as excessive pressure may damage the OLED.
5. Recommended soldering time and temperature limits for OLED switch:
Avoid temperatures exceeding 80°C at the OLED.
Wave Soldering: see Profile A in Supplement section.
Manual Soldering: see Profile A in Supplement section.
6. The IS series OLED devices are not process sealed.
7. Pixels acquire diminished brightness over time and use, and those most frequently habituated have greater reduction of brightness than those less used. To minimize this difference, operate OLED unit so that all pixels are used as consistently as possible.
8. Clean cap surface with dry cloth. If further cleaning is needed, wipe with dampened cloth using neutral cleanser and dry with clean cloth. Do not use organic solvent.
9. Proper serial resistors and buffers for signals should be used to prevent noise problems.

Storage

1. Store in original container and away from direct sunlight.
2. Keep away from static electricity.
3. Avoid extreme temperatures, high humidity, gaseous substances, and all forms of chemical contamination.

Mouser Electronics

Authorized Distributor

Click to View Pricing, Inventory, Delivery & Lifecycle Information:

[NKK Switches:](#)

[ISF15ACP4](#)

Данный компонент на территории Российской Федерации

Вы можете приобрести в компании MosChip.

Для оперативного оформления запроса Вам необходимо перейти по данной ссылке:

<http://moschip.ru/get-element>

Вы можете разместить у нас заказ для любого Вашего проекта, будь то серийное производство или разработка единичного прибора.

В нашем ассортименте представлены ведущие мировые производители активных и пассивных электронных компонентов.

Нашей специализацией является поставка электронной компонентной базы двойного назначения, продукции таких производителей как XILINX, Intel (ex.ALTERA), Vicor, Microchip, Texas Instruments, Analog Devices, Mini-Circuits, Amphenol, Glenair.

Сотрудничество с глобальными дистрибьюторами электронных компонентов, предоставляет возможность заказывать и получать с международных складов практически любой перечень компонентов в оптимальные для Вас сроки.

На всех этапах разработки и производства наши партнеры могут получить квалифицированную поддержку опытных инженеров.

Система менеджмента качества компании отвечает требованиям в соответствии с ГОСТ Р ИСО 9001, ГОСТ РВ 0015-002 и ЭС РД 009

Офис по работе с юридическими лицами:

105318, г.Москва, ул.Щербаковская д.3, офис 1107, 1118, ДЦ «Щербаковский»

Телефон: +7 495 668-12-70 (многоканальный)

Факс: +7 495 668-12-70 (доб.304)

E-mail: info@moschip.ru

Skype отдела продаж:

moschip.ru

moschip.ru_4

moschip.ru_6

moschip.ru_9