

11.43 ±0.25 [0.450 ±0.010]

RECOMMENDED PANEL CUTOUT
EMPFOHLENER FRONTPLATTEN-AUSSCHNITT

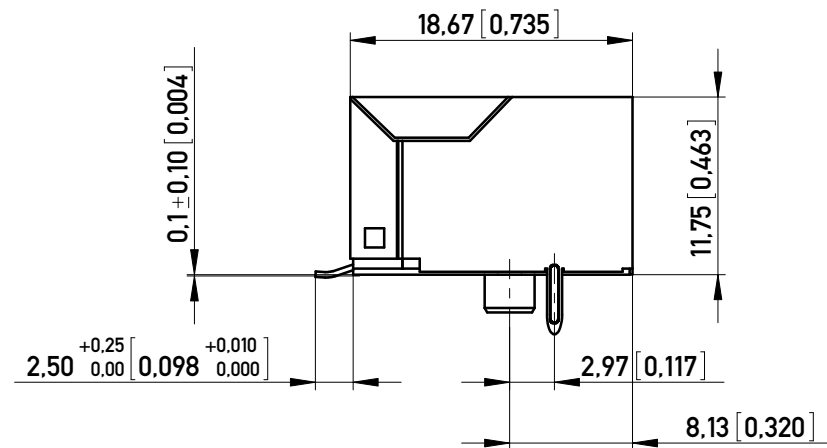
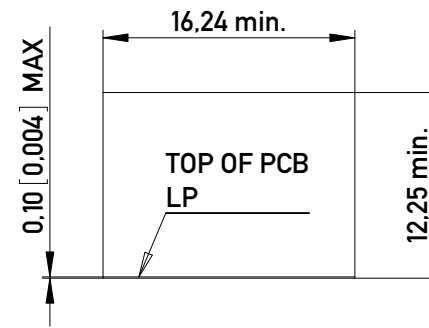

2.50 ^{+0.25}/_{0.00} [0.098 ^{+0.010}/_{0.000}]

RECOMMENDED PCB LAYOUT (COMPONENT SIDE VIEW)
EMPFOHLENES LEITERPLATTEN-LAYOUT (BESTUECKUNGSSEITE)
TOL. ±0.05 [0.002] UNLESS NOTED

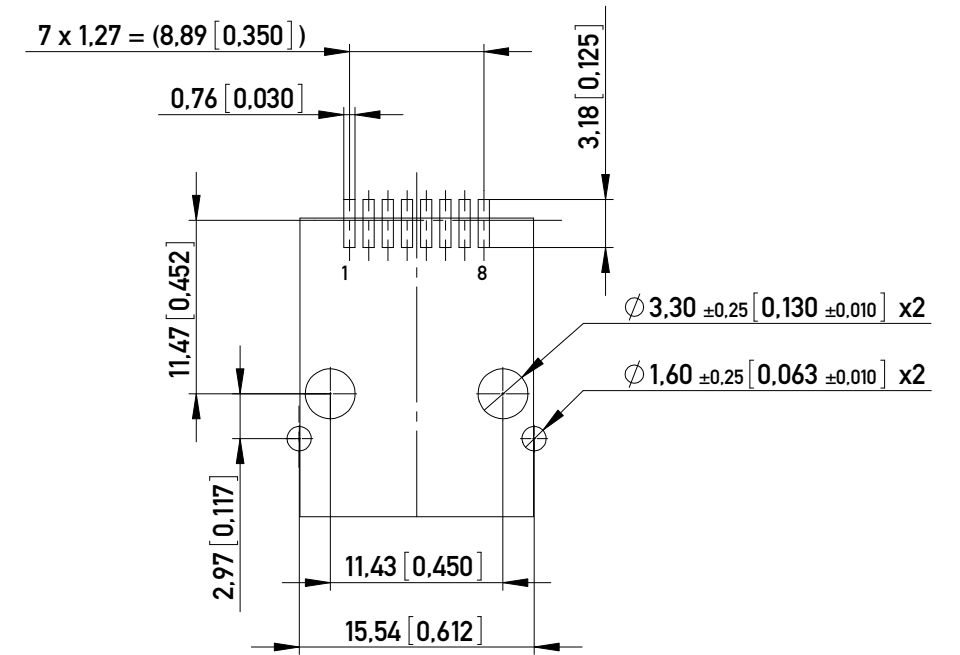

IMPROVED CONTACT DESIGN
(PRE BEND)

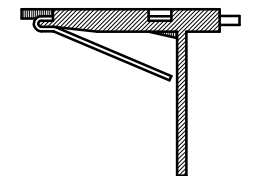

NOTE 1: WITH PEGS, SIDE GROUNDING PINS AND SMT TERMINALS
NOTE 2: RoHS COMPLIANT

Technical specifications

Materials & Finish	Standard applic.	Value
Insulation body	Standard description	PA46 30%
Contact material	Standard description	C521 (acc. JIS)
Contact finish, mating zone	Thickness of plating	30 µm Au over 50 µm Ni
Contact finish termination zone	Thickness of plating	80 µm Sn matt over 50 µm Ni
Shell/shield material	Standard description	C2680 (acc. JIS)
Plating shield / shielding pin		50 µm Ni

Assembly process	Value
Packaging	see chart
Solder temperature	260°C at 3-5s
Suitable assembly process	reflow

Approvals	UL 94	Value
UL insulation body		V0
UL File No.		E145613
RoHS compliant		Yes

Test Data	Standard applic.	Value
Mechanical properties		
Insertion/withdrawal force	IEC 603-7	max. 20 N
Mechanical operations	IEC 512-5. 9a	min. 1.000
Effectiveness of connector coupling device	IEC 512-8. 15f	50 N

Electrical properties		
Creepage / clearance distances		
a) Contact - contact	IEC 807-3	0.52 mm
b) Contact - shell	IEC 807-3	min. 1.0 mm
Voltage proof (Dielectric Withstand Voltage)		
a) Contact - contact	IEC 512-2. 4a	min. 1.000 V AC/DC
b) Contact - shell/testpanel	IEC 512-2. 4a	min. 1.500 V AC/DC
Current carrying capacity	IEC 512-3. 5b	1.5 A @ 25° C
Contact resistance	IEC 512-2. 2a	max. 30 mOhm
Insulation resistance	IEC 512-2. 3a	min. 500 MOhm

Environmental properties		
Operation temperature		0 - 70° C

PART NO. IDENT. NR.	PACKAGING VERPACKUNG	Scale	2:1
133602	TRAY (Standard) (SEE PAGE 2 of 2)	All Dimensions in mm	
203490	TAPE & REEL (SEE PAGE 2 of 2) 120 PIECES PER REEL	Designation	
Information: MAXCONN No.: SEE CHART		Subject to modification without prior notice. Drawing will not be updated.	
All rights reserved. Only for Information. To ensure that this is the latest version of this drawing, please contact one of the ERNI companies before using.		 www.ERNI.com MOD JACK - MJLS 8P8C, 1X1, SMT, CAT 3/4 203491	
d	23.11.2018	I (1/2)	
Index	Date	A3	
		Class	MJ

Copyright by ERNI Production GmbH & Co. KG
Proprietary notice pursuant to ISO 16016 to be observed.

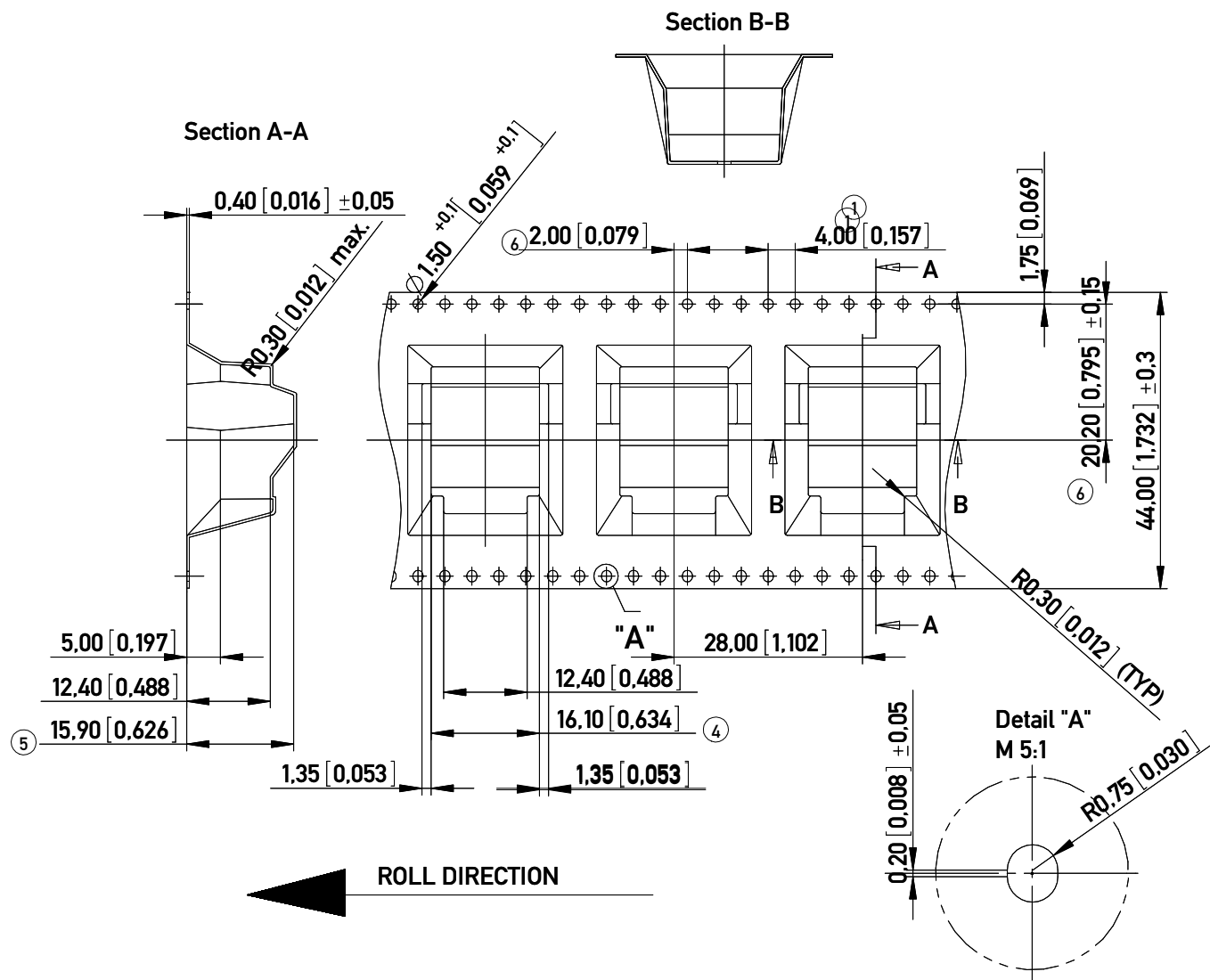

TAPE AND REEL INFORMATION
120 CONNECTORS PER REEL

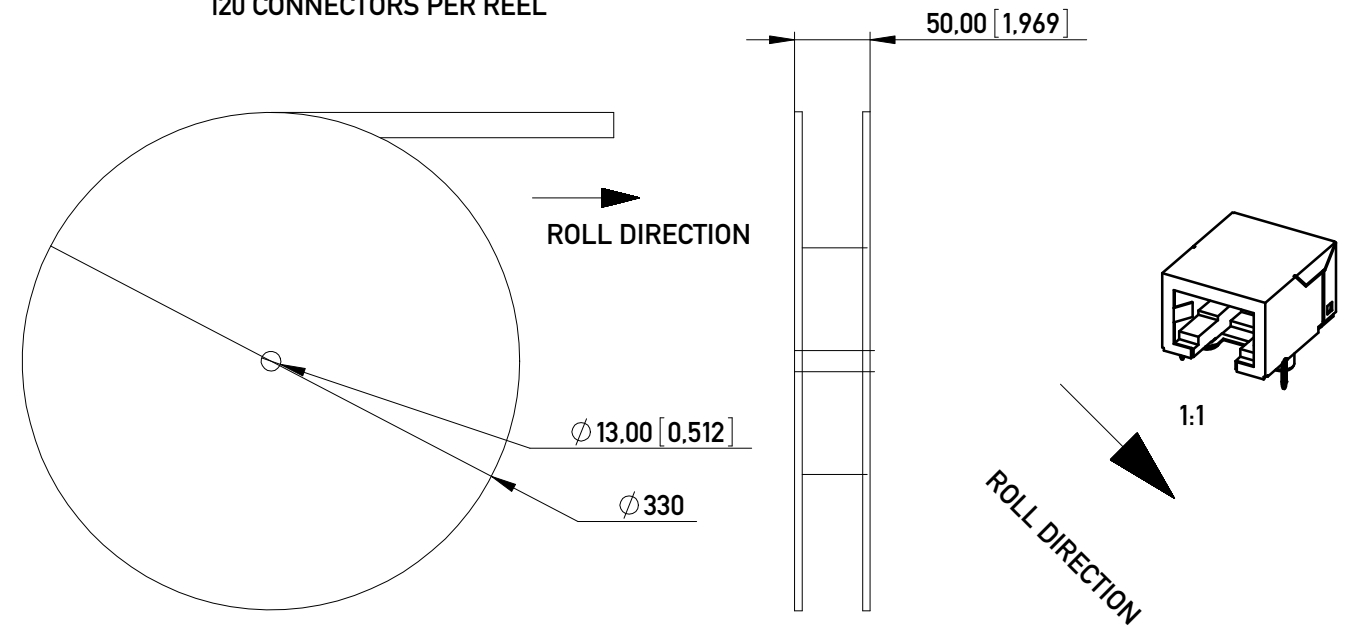

203490 TAPE & REEL PACKAGE

NOTE 1: 10 SPROCKET HOLE PITCH CUMULATIVE TOLERANCE ±0.2

NOTE 2: CAMBER NOT TO EXCEED 1 mm IN 100 mm

NOTE 3: MATERIAL: CLEAR ADVANTEK POLYSTYRENE

NOTE 4: MEASURED ON A PLANE 0.3 MM ABOVE THE BOTTOM OF THE POCKET

NOTE 5: MEASURED FROM A PLANE ON THE INSIDE BOTTOM OF THE POCKET TO THE TOP SURFACE OF THE CARRIER

NOTE 6: POKET POSITION RELATIVE TO SPROCKET HOLE MEASURED AS TRUE POSITION OF POCKET; NOT POCKET HOLE

133602 TRAY PACKAGE

Information:		Tolerances		Scale	2:1
All rights reserved. Only for Information. To ensure that this is the latest version of this drawing, please contact one of the ERNI companies before using.		Subject to modification without prior notice. Drawing will not be updated.		Designation	
		www.ERNI.com		MOD JACK - MJLS 8P8C, 1X1, SMT, CAT 3/4	
d	23.11.2018			203491	
Index	Date			1 (2/2) A3	
				Class	MJ

Copyright by ERNI Production GmbH & Co. KG
Proprietary notice pursuant to ISO 16016 to be observed.

Mouser Electronics

Authorized Distributor

Click to View Pricing, Inventory, Delivery & Lifecycle Information:

[ERNI Electronics:](#)

[133602](#)

Данный компонент на территории Российской Федерации

Вы можете приобрести в компании MosChip.

Для оперативного оформления запроса Вам необходимо перейти по данной ссылке:

<http://moschip.ru/get-element>

Вы можете разместить у нас заказ для любого Вашего проекта, будь то серийное производство или разработка единичного прибора.

В нашем ассортименте представлены ведущие мировые производители активных и пассивных электронных компонентов.

Нашей специализацией является поставка электронной компонентной базы двойного назначения, продукции таких производителей как XILINX, Intel (ex.ALTERA), Vicor, Microchip, Texas Instruments, Analog Devices, Mini-Circuits, Amphenol, Glenair.

Сотрудничество с глобальными дистрибьюторами электронных компонентов, предоставляет возможность заказывать и получать с международных складов практически любой перечень компонентов в оптимальные для Вас сроки.

На всех этапах разработки и производства наши партнеры могут получить квалифицированную поддержку опытных инженеров.

Система менеджмента качества компании отвечает требованиям в соответствии с ГОСТ Р ИСО 9001, ГОСТ РВ 0015-002 и ЭС РД 009

Офис по работе с юридическими лицами:

105318, г.Москва, ул.Щербаковская д.3, офис 1107, 1118, ДЦ «Щербаковский»

Телефон: +7 495 668-12-70 (многоканальный)

Факс: +7 495 668-12-70 (доб.304)

E-mail: info@moschip.ru

Skype отдела продаж:

moschip.ru

moschip.ru_4

moschip.ru_6

moschip.ru_9