



ON Semiconductor®

<http://onsemi.com>

LA6584JA

Monolithic Linear IC

Single-phase Full-wave Driver For Fan Motor

Overview

The LA6584JA is Single-phase bipolar fan motor is put into silent driving by means of BTL output linear drive, offering high efficiency and power saving by suppressing the reactive current. Lock protection and rotation signal (FG, RD) circuits are built in, ensuring optimum application to small fans for notebook PC, consumer equipment power supply, car audio system, CPU cooler, etc. that require high reliability and low noise.

Functions and Applications

- Single-phase full-wave driver for fan motor

Specifications

Absolute Maximum Ratings at $T_a = 25^\circ\text{C}$

Parameter	Symbol	Conditions	Ratings	Unit
Output voltage	V_{CC} max		15	V
Output current	I_{OUT} max		1.2	A
Output withstand voltage	V_{OUT} max		15	V
RD/FG output pin output Withstand voltage	$V_{RD/FG}$ max		15	V
RD/FG output current	$I_{RD/FG}$ max		5	mA
HB output voltage	I_B max		10	mA
Allowable dissipation	P_d max	Mounted on a specified board*	0.8	W
Operating temperature range	T_{opr}		-30 to +90	$^\circ\text{C}$
Storage temperature range	T_{stg}		-55 to +150	$^\circ\text{C}$

* Mounted on a specified board (114.3mm × 76.1mm × 1.6mm, Glass epoxy)

Stresses exceeding Maximum Ratings may damage the device. Maximum Ratings are stress ratings only. Functional operation above the Recommended Operating Conditions is not implied. Extended exposure to stresses above the Recommended Operating Conditions may affect device reliability.

LA6584JA

Recommended Operating Range at Ta = 25°C

Parameter	Conditions	Conditions	Ratings	Unit
Supply voltage	V _{CC}		2.8 to 14.0	V
Common-phase input voltage range of Hall input	V _{ICM}		0 to V _{CC} -1.5	V

Electrical Characteristics at Ta = 25°C V_{CC} = 12V, unless otherwise specified.

Parameter	Conditions	Conditions	Ratings			Unit
			min	typ	max	
Circuit current	I _{CC1}	During drive (CT = L)	4	6	9	mA
	I _{CC2}	During lock protection (CT = H)	2	4	6	mA
Lock detection capacitor charge current	I _{CT1}		2.0	2.8	3.5	μA
Capacitor discharge current	I _{CT2}		0.15	0.23	0.30	μA
Capacitor charge and discharge current ratio	R _{CT}	R _{CD} = I _{CT1} /I _{CT2}	9	12	15	-
CT charge voltage	V _{CT1}		1.6	1.7	1.8	V
CT discharge voltage	V _{CT2}		0.6	0.7	0.8	V
OUT output L saturation voltage	V _{OL}	I _O = 200mA		0.2	0.3	V
OUT output H saturation voltage	V _{OH}	I _O = 200mA		0.9	1.2	V
Hall input sensitivity	V _{HN}	Zero peak value (including offset and hysteresis)		7	15	mV
RD/FG output pin L voltage	V _{RD/FG}	I _{RD/FG} = 5mA		0.1	0.2	V
RD/FG output pin leak current	I _{RD/FGL}	V _{RD/FG} = 15V		1	30	μA
HB output L voltage	V _{HBL}	I _{HB} = 5mA	1.3	1.5	1.7	V

Package Dimensions

unit : mm (typ)

3179C

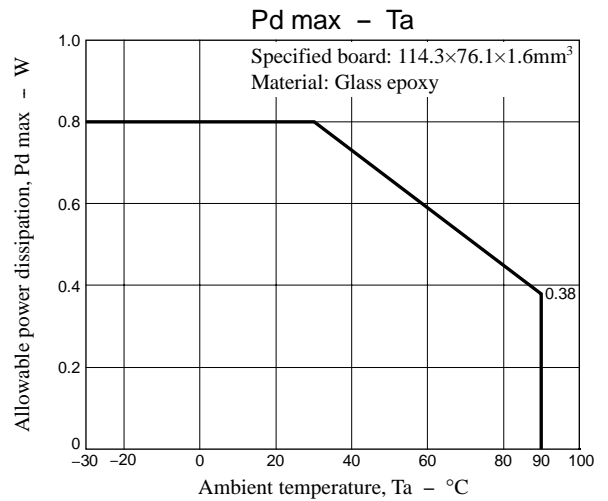
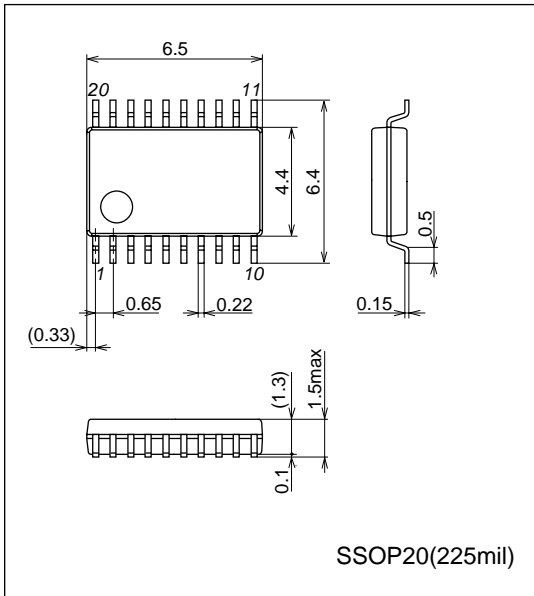

LA6584JA

Truth Table

IN-	IN+	CT	OUT1	OUT2	FG	RD	Mode
H	L	L	H	L	L	L	During rotation
L	H		L	H	H		
-	-	H	OFF	OFF	-	H	Lock protection

Pin Assignment

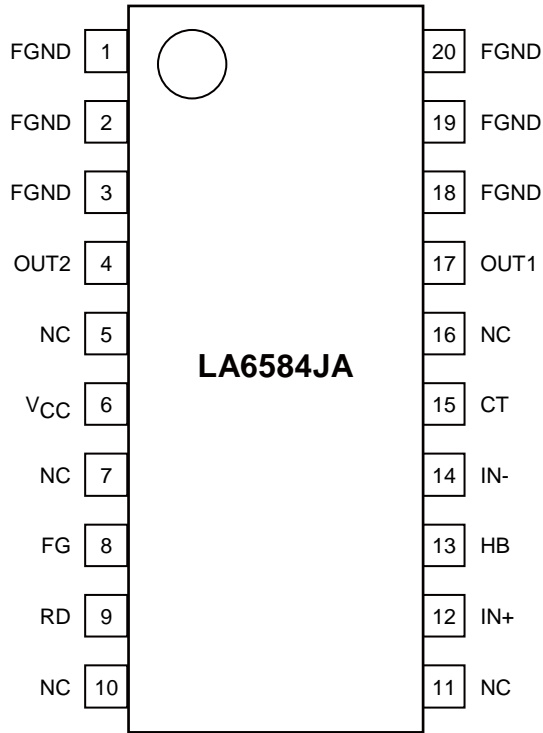

Top view

Sample Application Circuit

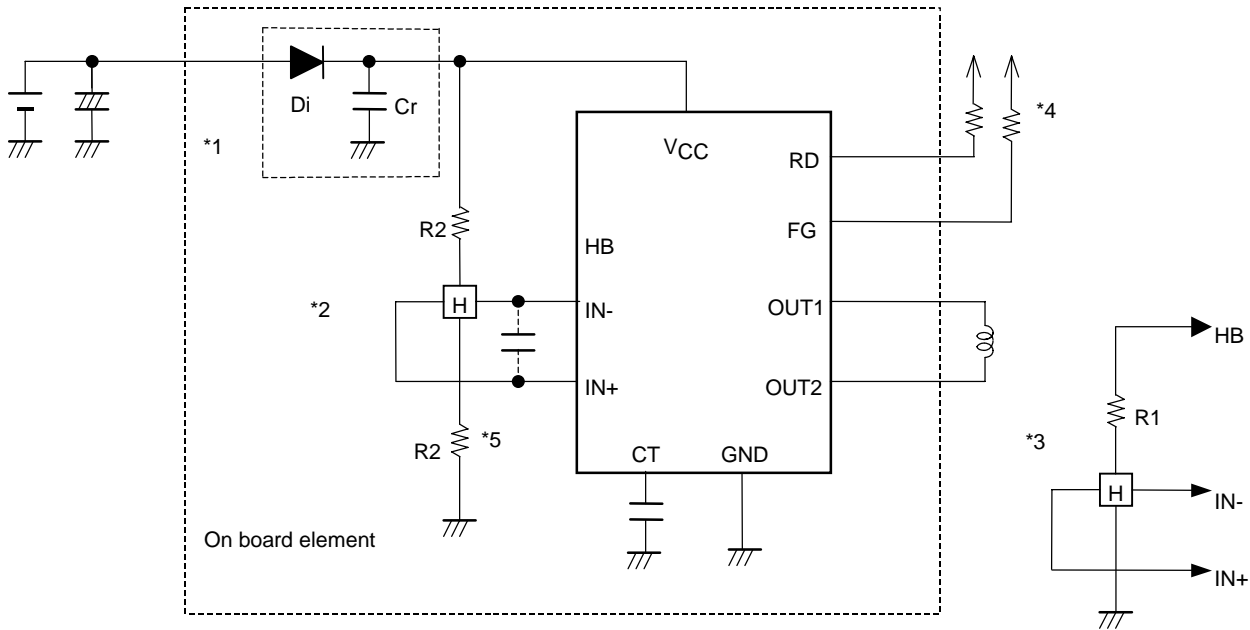

- *1 When Di to prevent breakdown in case of reverse connection is used, it is necessary to insert a capacitor Cr to secure the regenerative current route. Similarly, Cr is necessary to enhance the reliability when there is no capacitor near the fan power line.
- *2 To obtain Hall bias from V_{CC}, carry out $1/2 \times V_{CC}$ bias as shown in the figure. Linear driving is made through voltage control of the coil by amplifying the Hall output. When the Hall element output is large, the startup performance and efficiency are improved. Adjustment of the Hall element can reduce the noise further.
- *3 When the Hall bias is taken from the HB pin, constant-voltage bias is made with about 2.0V. Therefore, the Hall element can provide the output satisfactory in temperature characteristics. Adjustment of the Hall output amplitude is made with R1. (When V_{CC} = 12V, the step *2 above proves advantageous for IC heat generation.)
- *4 Keep this open when not used.
- *5 When the wiring from the Hall output to IC Hall input is long, noise may be carried through the wiring. In this case, insert the capacitor as shown in the figure.

Internal Equivalent Circuit

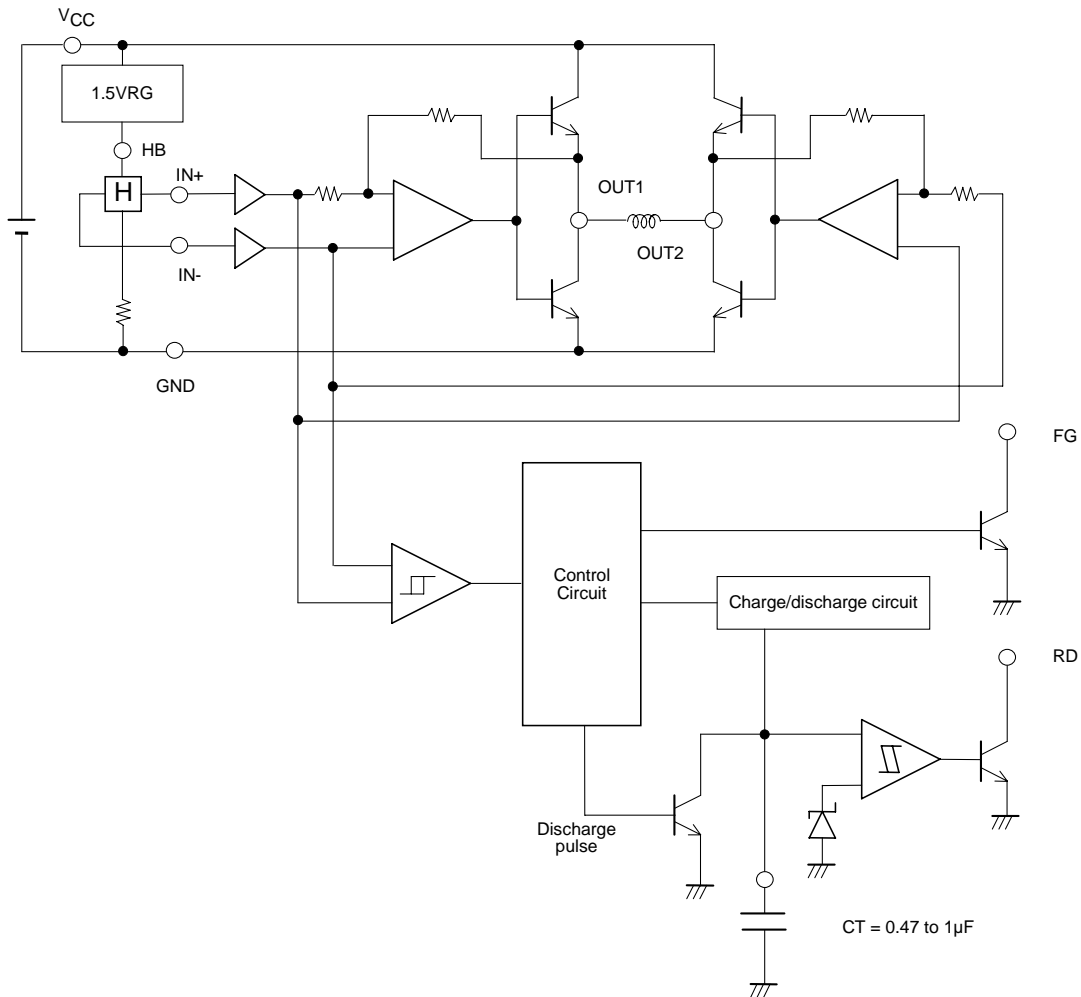

ON Semiconductor and the ON logo are registered trademarks of Semiconductor Components Industries, LLC (SCILLC). SCILLC owns the rights to a number of patents, trademarks, copyrights, trade secrets, and other intellectual property. A listing of SCILLC's product/patent coverage may be accessed at www.onsemi.com/site/pdf/Patent-Marking.pdf. SCILLC reserves the right to make changes without further notice to any products herein. SCILLC makes no warranty, representation or guarantee regarding the suitability of its products for any particular purpose, nor does SCILLC assume any liability arising out of the application or use of any product or circuit, and specifically disclaims any and all liability, including without limitation special, consequential or incidental damages. "Typical" parameters which may be provided in SCILLC data sheets and/or specifications can and do vary in different applications and actual performance may vary over time. All operating parameters, including "Typicals" must be validated for each customer application by customer's technical experts. SCILLC does not convey any license under its patent rights nor the rights of others. SCILLC products are not designed, intended, or authorized for use as components in systems intended for surgical implant into the body, or other applications intended to support or sustain life, or for any other application in which the failure of the SCILLC product could create a situation where personal injury or death may occur. Should Buyer purchase or use SCILLC products for any such unintended or unauthorized application, Buyer shall indemnify and hold SCILLC and its officers, employees, subsidiaries, affiliates, and distributors harmless against all claims, costs, damages, and expenses, and reasonable attorney fees arising out of, directly or indirectly, any claim of personal injury or death associated with such unintended or unauthorized use, even if such claim alleges that SCILLC was negligent regarding the design or manufacture of the part. SCILLC is an Equal Opportunity/Affirmative Action Employer. This literature is subject to all applicable copyright laws and is not for resale in any manner.

Данный компонент на территории Российской Федерации

Вы можете приобрести в компании MosChip.

Для оперативного оформления запроса Вам необходимо перейти по данной ссылке:

<http://moschip.ru/get-element>

Вы можете разместить у нас заказ для любого Вашего проекта, будь то серийное производство или разработка единичного прибора.

В нашем ассортименте представлены ведущие мировые производители активных и пассивных электронных компонентов.

Нашей специализацией является поставка электронной компонентной базы двойного назначения, продукции таких производителей как XILINX, Intel (ex.ALTERA), Vicor, Microchip, Texas Instruments, Analog Devices, Mini-Circuits, Amphenol, Glenair.

Сотрудничество с глобальными дистрибьюторами электронных компонентов, предоставляет возможность заказывать и получать с международных складов практически любой перечень компонентов в оптимальные для Вас сроки.

На всех этапах разработки и производства наши партнеры могут получить квалифицированную поддержку опытных инженеров.

Система менеджмента качества компании отвечает требованиям в соответствии с ГОСТ Р ИСО 9001, ГОСТ РВ 0015-002 и ЭС РД 009

Офис по работе с юридическими лицами:

105318, г.Москва, ул.Щербаковская д.3, офис 1107, 1118, ДЦ «Щербаковский»

Телефон: +7 495 668-12-70 (многоканальный)

Факс: +7 495 668-12-70 (доб.304)

E-mail: info@moschip.ru

Skype отдела продаж:

moschip.ru

moschip.ru_4

moschip.ru_6

moschip.ru_9