



82563EB/82564EB Gigabit Platform LAN Connect

Networking Silicon

Datasheet

Product Features

- IEEE 802.3ab compliant
 - Robust operation over the installed base of Category-5 (Cat-5) twisted pair cabling
- PICMG 3.1 compliant
 - Robust operation in backplane over Ethernet applications.
- Support for cable line lengths greater than 100 m (spec); 123 m physical
 - Robust end to end connections over various cable lengths
- Full duplex at 10, 100, or 1000 Mb/s and half duplex at 10 or 100 Mb/s.
- IEEE 802.3ab Auto-negotiation with Next Page support
 - Automatic link configuration including speed, duplex, and flow control
- 10/100 downshift
 - Automatic link speed adjustment with poor quality cable
- Automatic MDI crossover
 - Helps to correct for infrastructure issues
- Advanced Cable Diagnostics
 - Improved end-user troubleshooting
- Kumeran interface
 - Low pin count, high speed interface to the Intel® 631xESB/632xESB I/O Controller Hub
 - Allows PHY placement proximity to I/O back panel.
- 7 LED outputs per port (4 configurable plus 3 dedicated)
 - Link and Activity indications (10, 100, 1000 Mb/s) on each port
- Clock supplied to the 631xESB/632xESB
 - Cost optimized design
- Full chip power down
 - Support for lowest power state
- 100 pin TQFP Package
 - Smaller footprint and lower power dissipation compared to multi-chip MAC and PHY solutions
- Operating temperature: 0°C to 60° C (maximum) – heat sink or forced airflow not required
 - Simple thermal design
- Power Consumption: < 1.0 Watts per port (silicon power)
 - Minimize impact of incorporating dual Gigabit instead of Fast Ethernet
- Leaded and lead-free^a 100-pin TQFL with an Exposed-Pad*. Devices that are lead-free are marked with a circled “e3” and have a product code: HYXXXXX

a. This device is lead-free. That is, lead has not been intentionally added, but lead may still exist as an impurity at <1000 ppm. The Material Declaration Data Sheet, which includes lead impurity levels and the concentration of other Restriction on Hazardous Substances (RoHS) -banned materials, is available at:

ftp://download.intel.com/design/packtech/material_content_IC_Pack

In addition, this device has been tested and conforms to the same parametric specifications as previous versions of the device. For more information regarding lead-free products from Intel Corporation, contact your Intel Field Sales representative.



Revision History

Date	Revision	Comments
Nov 2007	2.9	Updated Tables 19, 20, 23, and 24. Updated Figures 5 and 6.
Oct 2007	2.8	Updated Table 16 "Recommended Operating Conditions".
April 2007	2.7	Updated Section 4.2, Table 16 "Core Digital Voltage Range".
Feb 2007	2.6	Updated Table 6.
May 2006	2.5	Initial public release.
April 2006	2.1	Removed "Preliminary" from section 4.9 "Power Consumption". Updated 1.9V external power supply parameters in Tables 16 and 19.
Nov 2005	2.0	Initial release (Intel Confidential).
Aug 2005	1.75	Added lead-free information. Added measured power consumption values. Updated crystal specifications (drive level now 750 μ W). Changed 1.8V power rail references to 1.9V.
Dec 2004	1.0	Major revisions in all sections.
Sep 2004	0.70	Added power sequencing.
Jul 2004	0.51	Changed pin 51 (page 13) from AVDD (1.8V) to AVDDR (3.3V).
May 2004	0.5	Initial release (Intel Secret).

Legal Notice

INFORMATION IN THIS DOCUMENT IS PROVIDED IN CONNECTION WITH INTEL® PRODUCTS. NO LICENSE, EXPRESS OR IMPLIED, BY ESTOPPEL OR OTHERWISE, TO ANY INTELLECTUAL PROPERTY RIGHTS IS GRANTED BY THIS DOCUMENT. EXCEPT AS PROVIDED IN INTEL'S TERMS AND CONDITIONS OF SALE FOR SUCH PRODUCTS, INTEL ASSUMES NO LIABILITY WHATSOEVER, AND INTEL DISCLAIMS ANY EXPRESS OR IMPLIED WARRANTY, RELATING TO SALE AND/OR USE OF INTEL PRODUCTS INCLUDING LIABILITY OR WARRANTIES RELATING TO FITNESS FOR A PARTICULAR PURPOSE, MERCHANTABILITY, OR INFRINGEMENT OF ANY PATENT, COPYRIGHT OR OTHER INTELLECTUAL PROPERTY RIGHT.

Intel products are not intended for use in medical, life saving, life sustaining, critical control or safety systems, or in nuclear facility applications.

Intel may make changes to specifications and product descriptions at any time, without notice.

This document contains information on products in the design phase of development. The information here is subject to change without notice. Do not finalize a design with this information.

Designers must not rely on the absence or characteristics of any features or instructions marked "reserved" or "undefined." Intel reserves these for future definition and shall have no responsibility whatsoever for conflicts or incompatibilities arising from future changes to them.

The 82563EB/82564EB Gigabit Platform LAN Connects discussed in this document may contain design defects or errors known as errata which may cause the product to deviate from published specifications. Current characterized errata are available on request.

Contact your local Intel sales office or your distributor to obtain the latest specifications and before placing your product order.

Copies of documents which have an ordering number and are referenced in this document, or other Intel literature, may be obtained from:

Intel Corporation
P.O. Box 5937
Denver, CO 80217-9808

or call in North America 1-800-548-4725, Europe 44-0-1793-431-155, France 44-0-1793-421-777, Germany 44-0-1793-421-333, other Countries 708-296-9333.

Intel® is a trademark or registered trademark of Intel Corporation or its subsidiaries in the United States and other countries.

*Other names and brands may be claimed as the property of others.

Copyright © Intel Corporation, 2007



Contents

1.0	Introduction.....	1
1.1	Document Scope.....	1
1.2	Reference Documents.....	1
1.3	Product Codes.....	2
2.0	Block Diagrams	3
3.0	Signal Descriptions.....	5
3.1	Signal Type Definitions.....	5
3.2	Shared PHY Pins	6
3.3	MDIO Interface	6
3.4	Port A PHY Interface	7
3.5	Port A Kumeran Interface.....	8
3.6	Port A LEDs.....	8
3.7	Reset, Power Down, and Initialization Signals	9
3.8	JTAG and IEEE Interface	9
3.9	Reserved Signals	10
3.10	Voltage Control Pins.....	10
3.11	Clock Generator Interface	11
3.12	Power/Ground Pins	11
3.13	Port B PHY Interface	13
3.14	Port B Kumeran Interface.....	14
3.15	Port B LEDs.....	15
4.0	Voltage, Temperature and Timing Specifications.....	17
4.1	Absolute Maximum Ratings.....	17
4.2	Recommended Operating Conditions	17
4.3	DC and AC Characteristics	17
4.4	Power Supply Connections	18
4.4.1	External LVR Power Delivery	18
4.4.2	Power Sequencing with External Regulators	20
4.4.3	Internally-Generated Power Delivery	21
4.4.4	Internal LVR Power Sequencing	22
4.5	Link (MDI) Interface.....	26
4.6	Kumeran (Serial) Interface	27
4.6.1	Transmit	27
4.6.2	Receive	28
4.6.3	Electrical Idle	29
4.7	Crystal	31
4.7.1	External Clock Oscillator	31
4.8	Reset and Initial Clock Timing.....	32
4.9	Power Consumption	33
5.0	Package and Pinout Information	37
5.1	Package Information	37
5.2	Thermal Specifications	39
5.3	Pinout Information	40



5.4	Interface Diagrams	43
5.5	Visual Pin Assignments	44

Figures

1	82563EB Dual Port Block Diagram	3
2	82564EB Single Port Block Diagram	3
3	82563EB/82564EB power up sequencing with external regulators	21
4	82563EB/82564EB power up sequencing with internal regulators	23
5	82563EB 1.9V and 1.2V internal LVR schematic.....	26
6	82564EB 1.9V and 1.2V internal LVR schematic.....	26
7	Kumeran (Serial) Transmit Eye Diagram	28
8	Kumeran (Serial) Receive Eye Diagram	29
9	External Clock Oscillator Connectivity to 82563EB/82564EB	31
10	82563EB/82564EB Reset Timing	32
11	Mechanical Information	37
12	Mechanical Specifications and Notes	38
13	82563EB/82564EB Interfaces	43
14	82563EB Dual Port Gigabit Platform LAN connect Pinout (Top View)	44
15	82564EB Single Port Gigabit Platform LAN Connect Pinout (Top View)	45

Tables

1	Product Ordering Codes	2
1	Shared PHY Pins	6
2	MDIO Interface Pins	6
3	Port A PHY Interface Pins.....	7
4	Port A Kumeran Interface Pins.....	8
5	Port A LEDs	8
6	Reset and Power Down Signals.....	9
7	JTAG Signals	9
8	Test Signals	10
9	Voltage Control Pins	10
10	Clock Generator Related Signals.....	11
11	Power/Ground Pins	11
12	Port B PHY Interface Pins.....	13
13	Port B Kumeran Interface Pins.....	14
14	Port B LEDs	15
15	Absolute Maximum Ratings	17
16	Recommended Operating Conditions	17
17	DC and AC Characteristics	17
18	3.3V External Power Supply Parameters	19
19	1.9V External Power Supply Parameters	19
20	1.2V External Power Supply Parameters	20
21	3.3V External Power Supply Parameters	21
22	82563EB/82564EB BOM (Bill of Material) of Components for Internal Regulator	23
23	1.9V Internal LVR Specification	24
24	1.2V Internal LVR Specification	24
25	PNP Specification	25
26	Link (MDI) Interface Electrical Specification.....	26
27	Kumeran (Serial) Transmit Specifications	27



28	Kumeran (Serial) Receive Specifications	28
29	Kumeran (Serial) Electrical Idle Detection.....	30
30	Kumeran (Serial) Electrical Idle Output	30
31	Crystal Parameters.....	31
32	Specification for External Clock Oscillator.....	32
33	Reset Specification.....	33
34	Power Supply Characteristics - D0a (Both Ports)	34
35	Power Supply Characteristics - D3cold - Wake Up Enabled (Both Ports).....	34
36	Power Supply Characteristics - Uninitialized/Disabled.....	34
37	Power Supply Characteristics - Complete Subsystem	35
38	Thermal Characteristics	39
39	82563EB/82564EB Pinout by Pin Number Order.....	40



Note: This page intentionally left blank.



1.0 Introduction

The Intel® 82563EB Gigabit Platform LAN Connect is a dual, compact Physical Layer Transceiver (PHY) component designed for 10/100/1000 Mb/s operation. This device uses the Kumeran interface port of the 631xESB/632xESB I/O Controller Hub enabling the routing of long distances up to 28 inches (~711 mm). The 82564EB Gigabit Platform LAN Connect is the single port implementation. The Intel® 82563EB and 82564EB allow for Gigabit Ethernet implementations in a very small package; easing routing constraints from the 631xESB/632xESB I/O Controller Hub to the PHY.

The Intel® 82563EB/82564EB devices are based upon proven PHY technology integrated into Intel's Gigabit Ethernet Controllers. The physical layer circuitry provides a standard IEEE 802.3 Ethernet interface for 1000BASE-T, 100BASE-TX, and 10BASE-T applications (802.3, 802.3u, and 802.3ab). The 82563EB/82564EB devices are capable of transmitting and receiving data at rates of 1000 Mb/s, 100 Mb/s, or 10 Mb/s.

1.1 Document Scope

This document contains datasheet specifications for the 82563EB/82564EB Gigabit Platform LAN Connect, including signal descriptions, DC and AC parameters, packaging data, and pinout information.

1.2 Reference Documents

This document assumes that the designer is acquainted with high-speed design and board layout techniques. The following documents provide application information:

- *82563EB/82564EB LAN on Motherboard Design Guide (AP-467)*, Intel Corporation.
- *82563EB/82564EB Gigabit Platform LAN Connect Specification Update*, Intel Corporation.
- *631xESB/632xESB I/O Controller Hub EEPROM Information Guide Application Note (AP-477)*, Intel Corporation.
- *82571/82572/ESB2 LAN System Manageability Application Note (AP-497)*, Intel Corporation.
- *IEEE Standard 1149.1*, 2001 Edition (JTAG). Institute of Electrical and Electronics Engineers (IEEE).
- *IEEE Standard 802.3*, 2002 Edition. Incorporates various IEEE Standards previously published separately. Institute of Electrical and Electronic Engineers (IEEE).
- *Intel® 631xESB/632xESB I/O Controller Hub External Design Specification (EDS)*, Volumes 1-3, Intel Corporation.
- *Bensley/Bensley-VS Platform Design Guide (PDG)*, Intel Corporation.
- *PICMG3.1 Ethernet/Fiber Channel Over PICMG 3.0 Draft Specification*, September 4, 2002, Version 0.90. PCI Industrial Computer Manufacturers Group (PICMG).

Software driver developers should contact their local Intel Representatives for programming information.



1.3 Product Codes

The following Table 1 lists the product ordering codes for the 82563EB dual port device and the 82564EB single port device.

Table 1. Product Ordering Codes

Device	Product Code
Dual Port (Leaded)	HU82563EB
Single Port (Leaded)	HU82564EB
Dual Port (Lead Free)	HY82563EB
Single Port (Lead Free)	HY82564EB



2.0 Block Diagrams

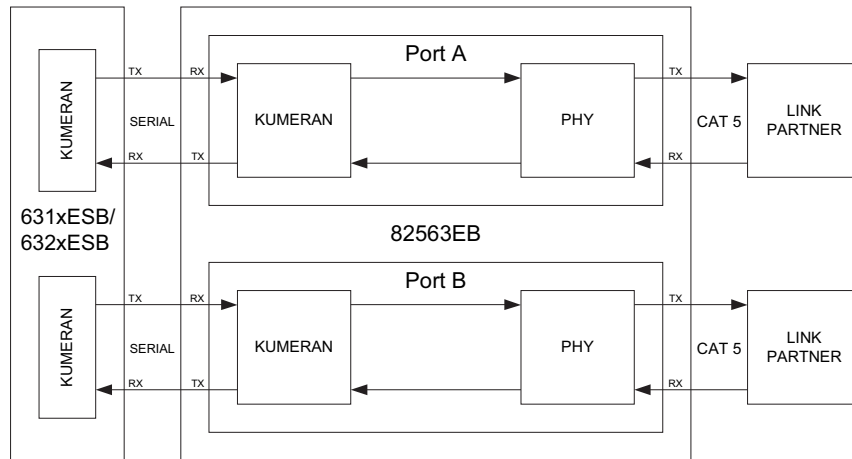

Figure 1. 82563EB Dual Port Block Diagram

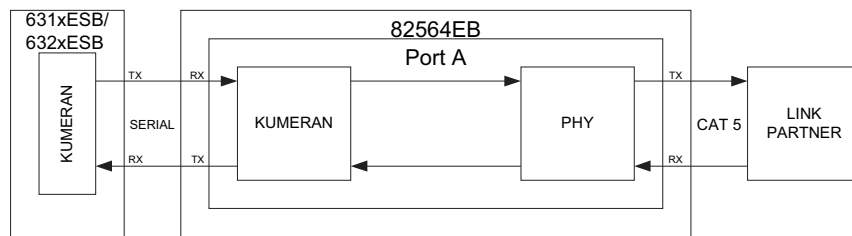

Figure 2. 82564EB Single Port Block Diagram



Note: This page intentionally left blank.



3.0 Signal Descriptions

3.1 Signal Type Definitions

The signals of 82563EB/82564EB are defined as follows:

- **I:** Standard input-only signal
- **I (T):** Functional input signal implemented as a bidirectional for test
- **O:** Standard output-only signal
- **O (T):** Functional output signal implemented as a bidirectional for test
- **I/O:** Bi-directional, tri-state input/output signal
- **A:** Analog signal
- **A-in:** Analog input signal
- **A-o:** Analog output signal
- **P:** Power signal
- **G:** Ground signal
- **NC:** No connect (these signals must not be connected to any traces or planes)
- **B:** Input bias

Signals may be further qualified to indicate whether an internal pull-up or pull-down is normally active. Unless otherwise stated, internal pull-up and pull-down impedances are between 50 K Ω and 130 K Ω .

- **PU:** Internal pull-up to VDD
- **PD:** Internal pull-down to VSS

Note: It may be desirable to leave some input signals as no-connects in certain system applications that rely on a device's internal pull-up or pull-down signal to be active. Care should be taken to ensure there are no long traces, such as far-away test points or errant trace routings, on any inputs which rely solely on internal pull-devices. Excess capacitance of dangling traces may generate charge and/or noise on inputs which exceeds the capability of the internal pull-device, leading to unpredictable component behavior.

In addition to a primary type, each pin can be classified according to one of the following sub-types based on its electrical characteristics, such as input and output voltages and drive strengths.

- **TTL:** TTL compatible inputs
- **TTL3:** TTL compatible pins with at least 3mA drive strength
- **TTL6:** TTL compatible pins with at least 6mA drive strength
- **TTL8:** TTL compatible pins with at least 8mA drive strength
- **TTL12:** TTL compatible pins with at least 12mA drive strength



3.2 Shared PHY Pins

Table 1. Shared PHY Pins

Signal Name	Pin	Type	Sub-Type	Description
PHY_REF	50	B	B	PHY Reference External 4.99 K Ω \pm 1% resistor connection to VSS.

3.3 MDIO Interface

Table 2. MDIO Interface Pins

Note: For normal operation, the MDIO interface is strapped externally according to Table 39 due to MDIO being an in-band operation.

Signal Name	Pin	Type	Sub-Type	Description
MDC	77	I (T)	TTL	Management Data Clock This signal is received from the 631xESB/632xESB as a clock timing reference for information transfer on the MDIO signal. It is not required to be a continuous signal and can be frozen when no management data is transferred. This signal has a maximum operating frequency of 2.5 MHz. A 1 - 10 K Ω \pm 5% pull-down resistor should be connected to this pin.
MDIO	76	I/O PU	TTL6	Management Data Input/Output Bi-directional data signal of the management data interface. This pin has an internal pull-up. This signal can be left disconnected (or pulled up) if not used.
MDIO_ADD[0] MDIO_ADD[1] MDIO_ADD[2] MDIO_ADD[3]	78 79 18 19	I (T)	TTL	Bits 4:1 of MDIO address These bits are latched at the assertion of PHY_PWR_GOOD or the de-assertion of PHY_RESET_N or PHY_SLEEP. They set the MDIO address as follows: <ul style="list-style-type: none"> • bit 1 = MDIO_ADD[0] • bit 2 = MDIO_ADD[1] • bit 3 = MDIO_ADD[2] • bit 4 = MDIO_ADD[3] A 1 - 10 k Ω \pm 5% pull-down resistor should be connected to each of these pins.



3.4 Port A PHY Interface

Note: Port A on the 82563EB/82564EB corresponds to connection to Port 0 on the 631xESB/632xESB.

Table 3. Port A PHY Interface Pins

Signal Name	Pin	Type	Sub-Type	Description
MDIA_PLUS[0] MDIA_MINUS[0]	27 28	A	A	<p>Media Dependent Interface for Port A, bit 0</p> <p>1000BASE-T: In MDI configuration, MDI[0]+/- corresponds to BI_DA+/- and in MDIX configuration MDI[0]+/- corresponds to BI_DB+/-.</p> <p>100BASE-TX: In MDI configuration, MDI[0]+/- is used for the transmit pair and in MDIX configuration MDI[0]+/- is used for the receive pair.</p> <p>10BASE-T: In MDI configuration, MDI[0]+/- is used for the transmit pair and in MDIX configuration MDI[0]+/- is used for the receive pair.</p>
MDIA_PLUS[1] MDIA_MINUS[1]	31 32	A	A	<p>Media Dependent Interface for Port A, bit 1</p> <p>1000BASE-T: In MDI configuration, MDI[1]+/- corresponds to BI_DB+/- and in MDIX configuration MDI[1]+/- corresponds to BI_DA+/-.</p> <p>100BASE-TX: In MDI configuration, MDI[1]+/- is used for the receive pair and in MDIX configuration MDI[1]+/- is used for the transmit pair.</p> <p>10BASE-T: In MDI configuration, MDI[1]+/- is used for the receive pair and in MDIX configuration MDI[1]+/- is used for the transmit pair.</p>
MDIA_PLUS[2] MDIA_MINUS[2]	33 34	A	A	<p>Media Dependent Interface for Port A, bit 2</p> <p>1000BASE-T: In MDI configuration, MDI[2]+/- corresponds to BI_DC+/- and in MDIX configuration MDI[2]+/- corresponds to BI_DD+/-.</p> <p>100BASE-TX: Unused.</p> <p>10BASE-T: Unused.</p>
MDIA_PLUS[3] MDIA_MINUS[3]	36 37	A	A	<p>Media Dependent Interface for Port A, bit 3</p> <p>1000BASE-T: In MDI configuration, MDI[3]+/- corresponds to BI_DD+/- and in MDIX configuration MDI[3]+/- corresponds to BI_DC+/-.</p> <p>100BASE-TX: Unused.</p> <p>10BASE-T: Unused.</p>
LINK_A	65	I/O	TTL8	<p>PHY A Link Indication</p> <p>This signal is registered at the rising edge of PHY_PWR_GOOD, and is used to determine the clock speed used for PHY_CLK_OUT. Once PHY_PWR_GOOD is 1, LINK_A will always be an output and indicate link up.</p>



3.5 Port A Kumeran Interface

Table 4. Port A Kumeran Interface Pins

Signal Name	Pin	Type	Sub-Type	Description
TXA_PLUS, TXA_MINUS	90 91	A-o	A	Port A KumeranTX Pair Differential Kumeran Transmit interface.
RXA_PLUS, RXA_MINUS	93 94	A-in	A	Port A Kumeran RX Pair Differential Kumeran Receive interface.

3.6 Port A LEDs

Table 5. Port A LEDs

Signal Name	Pin	Type	Sub-Type	Description
LEDA_LINK_UP_N	73	O	TTL12	LED 0 – Link Up LED This corresponds to port 0's LED#0 from the 631xESB/632xESB.
LEDA_ACTIVITY_N	72	O	TTL12	LED 1 – 10 Mbps LED This corresponds to port 0's LED#1 from the 631xESB/632xESB.
LEDA_SPEED_100_N	71	O	TTL12	LED 2 – 100 Mbps LED This corresponds to port 0's LED#2 from the 631xESB/632xESB.
LEDA_SPEED_1000_N	70	O	TTL12	LED 3 – 1000 Mbps LED This corresponds to port 0's LED#3 from the 631xESB/632xESB.
LEDA_DUPLEX	68	O	TTL12	LED 4 – Full Duplex LED This LED will light when port 0's PHY is operating in Full Duplex Mode
LEDA_TX_ACTIVITY	67	O	TTL12	LED 5 – Transmit Activity LED This LED will light when the port 0's PHY transmits a packet
LEDA_RX_ACTIVITY	66	O	TTL12	LED 6 – Receive Activity LED This LED will light when the port 0's PHY receives a packet This pin also functions as the clock view pin and will output clock signals required for IEEE conformance testing. This pin should have a stuffing option for a test header.



3.7 Reset, Power Down, and Initialization Signals

Table 6. Reset and Power Down Signals

Signal Name	Pin	Type	Sub-Type	Description
PHY_PWR_GOOD	83	I	TTL	Power Good (Power-On Reset) The PHY_PWR_GOOD signal indicates good power is available for The device. When set to 0b, the entire chip will be held in a reset state.
PHY_RESET_N	81	I	TTL	Reset When set to 0b, resets the device, including PHY and Kumeran logic. Needs an external pull-up resistor if the signal isn't continuously being driven from an external source.
PHY_SLEEP	80	I (T)	TTL	Sleep / Power Down This will power down the PHY and the Kumeran of both ports. Needs an external pull-down resistor, if the signal isn't continuously being driven from an external source.
TEST_JTAG	95	I PU	TTL	Enable JTAG Pin Control This pin should be pulled high through a 1 to 10 K Ω 5% resistor in normal operation.

3.8 JTAG and IEEE Interface

Table 7. JTAG Signals

Signal Name	Pin	Type	Sub-Type	Description
JTAG_TCK	100	I	TTL	JTAG Clock This pin should be pulled high through a 1 to 10 K Ω 5% resistor in normal operation.
JTAG_TDI	1	I PU	TTL	JTAG Serial Data Input If not using JTAG, this pin may be pulled high through a 1 to 10 K Ω 5% resistor
JTAG_TDO	99	O	TTL3	JTAG Serial Data Output
JTAG_TMS	3	I PU	TTL	JTAG TMS Input If not using JTAG, this pin may be pulled high through a 1 to 10 K Ω 5% resistor



3.9 Reserved Signals

Table 8. Test Signals

Signal Name	Pin	Type	Sub-Type	Description
RESERVED_NC	4 5 6 8 9 10 13 14 15 17 26 49 52 53 98	NC	NC	<p>Reserved No Connect</p> <p>This pin should be left disconnected in normal operation. Connecting any of these pins may cause adverse effects and will not be supported.</p>
RESERVED_PD	82	I (T)	TTL	<p>Reserved, Pull-down</p> <p>This signal used in the XOR chain. It should be pulled to VSS via a 1 to 10 KΩ resistor.</p>

3.10 Voltage Control Pins

Table 9. Voltage Control Pins

Signal Name	Pin	Type	Sub-Type	Description
CTRL_18	25	A	A	<p>1.9V LVR Power Output Reference</p> <p>Voltage control for an external 1.9V PNP transistor in order to produce a linearly-regulated supply.</p> <p>If the 1.9V internal voltage regulator control circuit is not used, connect the CTRL_18 pin to VSS through a 10 KΩ resistor.</p>
CTRL_12	23	A	A	<p>1.2V LVR Power Output Reference</p> <p>Voltage control for an external 1.2V PNP transistor in order to produce a linearly-regulated supply.</p> <p>If the 1.2V internal voltage regulator control circuit is not used, connect the CTRL_12 pin to VSS through a 10 KΩ resistor.</p>



3.11 Clock Generator Interface

Table 10. Clock Generator Related Signals

Signal Name	Pin	Type	Sub-Type	Description
XTAL1	21	I	TTL	25 MHz Clock/Crystal Input 25 MHz +/- 50 ppm input. Can be connected to an oscillator or a crystal. If using a crystal, XTAL2 must be connected as well. If a crystal is used, it must be placed within ½-inch of the XTAL1 and XTAL2 chip pins.
XTAL2	20	A-o	A	25 MHz Crystal Output Output of internal oscillator circuit used to drive crystal into oscillation. If using an oscillator, XTAL2 is left as a no connect.
PHY_CLK_OUT	96	O	TTL8	Clock Output Output clock available for use by a 631xESB/632xESB or other component(s). The speed depends on the how LINK_A is sampled at LAN_PWR_GOOD assertion: If LINK_A is 0b, the clock speed is 62.5 MHz. If LINK_A is 1b, the clock speed is 25 MHz. The output clock can be disabled depending on how LINK_B is sampled at LAN_PWR_GOOD assertion: If LINK_B is 0b: Clock output enabled (pulled-down). If LINK_B is 1b: Clock output disabled (no connect).

3.12 Power/Ground Pins

Table 11. Power/Ground Pins (Sheet 1 of 2)

Signal Name	Pin	Type	Sub-Type	Description
VSS	Central Pad	G	G	Ground Exposed-Pad* The ground is provided through a large central pad on the bottom side of the package.
VSS	89	G	G	Ground
VDDO	11 22 60 75 97	P	P	3.3V I/O Ring Power



Table 11. Power/Ground Pins (Sheet 2 of 2)

Signal Name	Pin	Type	Sub-Type	Description
DVDD	2 7 12 16 59 64 69 74	P	P	1.2V Digital Power
AVDD	29 30 35 40 45 46	P	P	1.9V Analog Power for PHY
AVDDF	86 92	P	P	1.9V Analog Power for Kumeran
AVDDR	24 51	P	P	3.3V Analog Power for Voltage Regulators



3.13 Port B PHY Interface

Note: Port B on the 82563EB dual port device corresponds to connection to Port 1 on the 631xESB/632xESB. There is no port B on the 82564EB.

Table 12. Port B PHY Interface Pins (Sheet 1 of 2)

Signal Name	Pin	Type	Sub-Type	Description	Connection on 82564EB Single Port Device
MDIB_PLUS[0] MDIB_MINUS[0]	48 47	A	A	Media Dependent Interface for Port B, bit 0 1000BASE-T: In MDI configuration, MDI[0]+/- corresponds to BI_DA+/- and in MDIX configuration MDI[0]+/- corresponds to BI_DB+/-. 100BASE-TX: In MDI configuration, MDI[0]+/- is used for the transmit pair and in MDIX configuration MDI[0]+/- is used for the receive pair. 10BASE-T: In MDI configuration, MDI[0]+/- is used for the transmit pair and in MDIX configuration MDI[0]+/- is used for the receive pair.	No-connect
MDIB_PLUS[1] MDIB_MINUS[1]	44 43	A	A	Media Dependent Interface for Port B, bit 1 1000BASE-T: In MDI configuration, MDI[1]+/- corresponds to BI_DB+/- and in MDIX configuration MDI[1]+/- corresponds to BI_DA+/-. 100BASE-TX: In MDI configuration, MDI[1]+/- is used for the receive pair and in MDIX configuration MDI[1]+/- is used for the transmit pair. 10BASE-T: In MDI configuration, MDI[1]+/- is used for the receive pair and in MDIX configuration MDI[1]+/- is used for the transmit pair.	No-connect



Table 12. Port B PHY Interface Pins (Sheet 2 of 2)

Signal Name	Pin	Type	Sub-Type	Description	Connection on 82564EB Single Port Device
MDIB_PLUS[2] MDIB_MINUS[2]	42 41	A	A	Media Dependent Interface for Port B, bit 2 1000BASE-T: In MDI configuration, MDI[2] +/- corresponds to BI_DC +/- and in MDIX configuration MDI[2] +/- corresponds to BI_DD +/-. 100BASE-TX: Unused. 10BASE-T: Unused.	No-connect
MDIB_PLUS[3] MDIB_MINUS[3]	39 38	A	A	Media Dependent Interface for Port B, bit 3 1000BASE-T: In MDI configuration, MDI[3] +/- corresponds to BI_DD +/- and in MDIX configuration MDI[3] +/- corresponds to BI_DC +/-. 100BASE-TX: Unused. 10BASE-T: Unused.	No-connect
LINK_B	54	I/O PD	TTL8	PHY B Link Indication This signal is registered at the rising edge of PHY_PWR_GOOD, and is used to determine whether PHY_CLK_OUT is output. See the PHY_CLK_OUT pin for details. Once PHY_PWR_GOOD is 1b, LINK_B will always be an output and indicate link up.	See Table 10

3.14 Port B Kumeran Interface

Table 13. Port B Kumeran Interface Pins

Signal Name	Pin	Type	Sub-Type	Description	Connection on 82564EB Single Port Device
TXB_PLUS TXB_MINUS	88 87	A-o	A	Port B Kumeran TX Pair Differential Kumeran Transmit interface.	No-connect
RXB_PLUS RXB_MINUS	85 84	A-in	A	Port B Kumeran RX Pair Differential Kumeran Receive interface.	No-connect



3.15 Port B LEDs

Table 14. Port B LEDs

Signal Name	Pin	Type	Sub-Type	Description	Connection on 82564EB Single Port Device
LEDB_LINK_UP_N	63	O	TTL12	LED 0 – Link Up/Activity LED This corresponds to port 1's LED#0 from the 631xESB/632xESB.	No-connect
LEDB_ACTIVITY_N	62	O	TTL12	LED 1 – 10 Mbps LED This corresponds to port 1's LED#1 from the 631xESB/632xESB.	No-connect
LEDB_SPEED_100_N	61	O	TTL12	LED 2 – 100 Mbps LED This corresponds to port 1's LED#2 from the 631xESB/632xESB.	No-connect
LEDB_SPEED_1000_N	58	O	TTL12	LED 3 – 1000 Mbps LED This corresponds to port 1's LED#3 from the 631xESB/632xESB.	No-connect
LEDB_DUPLEX	57	O	TTL12	LED 4 – Full Duplex LED This LED will light when port 1's PHY is operating in Full Duplex Mode	No-connect
LEDB_TX_ACTIVITY	56	O	TTL12	LED 5 – Transmit Activity LED This LED will light when port 1's PHY transmits a packet	No-connect
LEDB_RX_ACTIVITY	55	O	TTL12	LED 6 – Receive Activity LED This LED will light when port 1's PHY receives a packet This pin also functions as the clock view pin and will output clock signals required for IEEE conformance testing. This pin should have a stuffing option for a test header.	No-connect



Note: This page intentionally left blank.



4.0 Voltage, Temperature and Timing Specifications

4.1 Absolute Maximum Ratings

Table 15. Absolute Maximum Ratings^a

Symbol	Parameter	Min	Max	Unit
V_{DD}	DC supply voltage	-0.3	4.6	V
V_{IN}	Input voltage	-1.0	$V_{DD} + 0.3$	V
I_{IN}	DC input pin current	-10	10	mA
T_{STG}	Storage temperature	-40	125	°C

a. Maximum ratings are referenced to ground (VSS). Permanent device damage is likely to occur if the ratings in this table are exceeded for an indefinite duration. These values should not be used as the limits for normal device operations.

4.2 Recommended Operating Conditions

Table 16. Recommended Operating Conditions

Symbol	Parameter	Condition	Min	Typ	Max	Unit
T_{OP}	Operating Temperature	Convection only ^a	0		60	°C
V_{DD}	Periphery Voltage Range	3.3V	3.00	3.30	3.60	V
V_D	Core Digital Voltage Range	1.2V	1.08	1.20	1.32	V
V_A	Analog V_{DD} Range	1.9V	1.80	1.90	2.09	V

a. Higher ambient temperatures may be possible with forced airflow.

4.3 DC and AC Characteristics

Table 17. DC and AC Characteristics (Sheet 1 of 2)

Symbol	Parameter	Condition	Min	Typ	Max	Unit
V_{IL}	Voltage input LOW	-	-0.5	-	0.8	V
V_{IH}	Voltage input HIGH	-	2.0	-	$V_{DD} + 0.3$	V
V_{OL}	Voltage output LOW	-	-	-	0.4	V
V_{OH}	Voltage output HIGH	-	2.4	-	-	V



Table 17. DC and AC Characteristics (Sheet 2 of 2)

Symbol	Parameter	Condition	Min	Typ	Max	Unit
I_{OL}	Output current LOW 3mA drivers (TTL3)	V_{OL}	3	-	-	mA
	6mA drivers (TTL6)	V_{OL}	6	-	-	mA
	12mA drivers (TTL12)	V_{OL}	12	-	-	mA
I_{OH}	Output current HIGH 3mA drivers (TTL3)	V_{OH}	-3	-	-	mA
	6mA drivers (TTL6)	V_{OH}	-6	-	-	mA
	12mA drivers (TTL12)	V_{OH}	-12	-	-	mA
I_{IN}	Input Current TTL inputs	$V_{IN} = V_{DD}$ or V_{SS}	-10	± 1	10	μA
	Inputs with pull-down resistors	$V_{IN} = V_{DD}$	23		72	μA
	TTL inputs with pull-up resistors	$V_{IN} = V_{SS}$	-23		-72	μA
I_{OZ}	3-state output leakage current	$V_{OH} = V_{DD}$ or V_{SS}	-10	± 1	10	μA
C_{IN}	Input capacitance	Any input and bi-directional buffer	-	2.5	-	pF
C_{OUT}	Output capacitance	Any output buffer	-	2.0	-	pF
R_{PUD}	Internal Pull-up/down Resistor value	-	50	-	130	k Ω

4.4 Power Supply Connections

There are two options in providing power to the 82563EB/82564EB:

- Connecting the 82563EB/82564EB to three external power supplies with nominal voltages of 3.3V, 1.9V, and 1.2V covered in Section 4.4.1.
- Powering the 82563EB/82564EB with only an external 3.3V supply, and using internal power regulators from the 82563EB/82564EB combined with external PNP transistors to supply the 1.9V and 1.2V levels. covered in Section 4.4.3.

4.4.1 External LVR Power Delivery

The following power supply requirements apply to designs in which the 82563EB/82564EB is supplied by external voltage regulators. These systems do not use the internal regulator logic built into the 82563EB/82564EB as described in Section 4.4.3.



Table 18. 3.3V External Power Supply Parameters

Title	Description	Min	Max	Units
Rise Time	Time from 10% to 90% mark	2	200	ms
Monotonicity	Voltage dip allowed in ramp	-	300	mV
Slope	Ramp rate at any given time between 10% and 90% Min: 0.8*V(min)/Rise time (max) Max: 0.8*V(max)/Rise time (min)	-	1500	mV/ms
Operational Range	Voltage range for normal operating conditions	3.0	3.6	V
Ripple	Maximum voltage ripple (peak to peak) ^a	-	100	mV
Overshoot	Maximum overshoot allowed	-	660	mV
Overshoot Settling Time	Maximum overshoot allowed duration. (At that time delta voltage should be lower than 5 mV from steady state voltage)	-	3	ms

a. The peak to peak output rippled is measured at 20 MHz Bandwidth within the operational range.

Table 19. 1.9V External Power Supply Parameters

Title	Description	Min	Max	Units
Rise Time	Time from 10% to 90% mark	2	200	ms
Monotonicity	Voltage dip allowed in ramp	-	180	mV
Slope	Ramp rate at any given time between 10% and 90% Min: 0.8*V(min)/Rise time (max) Max: 0.8*V(max)/Rise time (min)	-	1500	mV/ms
Operational Range	Voltage range for normal operating conditions	1.80	2.09	V
Ripple	Maximum voltage ripple (peak to peak) ^a	-	100	mV
Overshoot	Maximum overshoot allowed	-	360	mV
Overshoot Settling Time	Maximum overshoot allowed duration. (At that time delta voltage should be lower than 5 mV from steady state voltage)	-	1.5	ms
Decoupling Capacitance	Capacitance range	5	-	μF
Capacitance ESR	Equivalent series resistance of output capacitance	-	100	M Ω

a. The peak to peak output ripple is measured at 20 MHz Bandwidth within the operational range.



Table 20. 1.2V External Power Supply Parameters

Title	Description	Min	Max	Units
Rise Time	Time from 10% to 90% mark	1.5	200	ms
Monotonicity	Voltage dip allowed in ramp	-	120	mV
Slope	Ramp rate at any given time between 10% and 90% Min: 0.8*V(min)/Rise time (max) Max: 0.8*V(max)/Rise time (min)	-	1500	mV/ms
Operational Range	Voltage range for normal operating conditions	1.08	1.32	V
Ripple	Maximum voltage ripple (peak to peak) ^a	-	100	mV
Overshoot	Maximum overshoot allowed	-	240	mV
Overshoot Duration	Maximum overshoot allowed duration. (At that time delta voltage should be lower than 5 mV from steady state voltage)	-	1	ms
Decoupling Capacitance	Capacitance range	5	-	μF
Capacitance ESR	Equivalent series resistance of output capacitance	-	100	MΩ

a. The peak to peak output ripple is measured at 20 MHz Bandwidth within the operational range. The ripple must be included within the operational range.

4.4.2 Power Sequencing with External Regulators

The following power-on/off sequence should be applied when external power supplies are in use.

Designs must comply with the required power sequence to avoid risk of either latch-up or forward biased internal diodes.

The general rule of thumb is that the 82563EB/82564EB power sequencing should power up the three power rails in the following order: 3.3V → 1.9V → 1.2V. However, if this general guideline is not followed, there are specific requirements that must be adhered that are listed in the following two sections.

4.4.2.1 External LVR Power up Sequencing and Tracking

Sequencing of the external supplies during power up may be necessary to ensure that the device is not electrically overstressed and does not latch-up. These requirements are shown in Figure 3.

- The 82563EB/82564EB core voltage (1.2V) cannot exceed the 3.3V supply by more than 0.5V at any time during the power up. The 82563EB/82564EB core voltage (1.2V) can not exceed the 1.9V supply by more than 0.5V at any time during the power up. The core voltage is not required to begin ramping before the 3.3V or the 1.9V supply.
- The 82563EB/82564EB analog voltage (1.9V) cannot exceed the 3.3V supply by more than 0.5V at any time during the power up. The analog voltage is not required to begin ramping before the 3.3V supply.

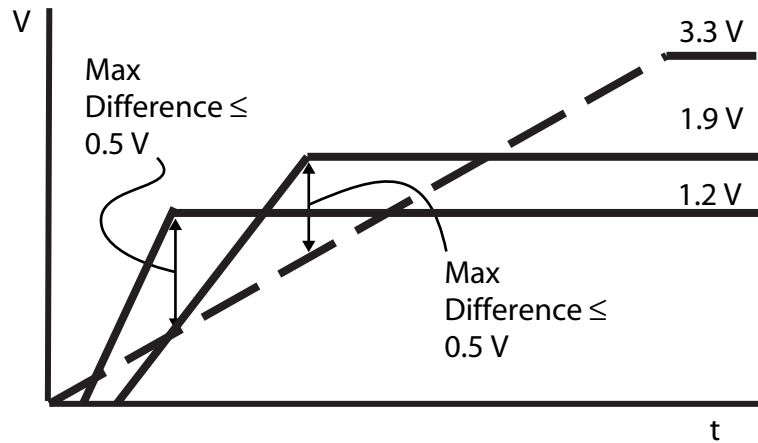

Figure 3. 82563EB/82564EB power up sequencing with external regulators

4.4.2.2 External LVR Power down Sequencing

There are no specific power down sequencing and tracking requirements for the 82563EB/82564EB silicon. The risk of latch-up or electrical overstress is small because only the charge stored in the decoupling capacitors is left in the system.

4.4.3 Internally-Generated Power Delivery

The 82563EB/82564EB has two internal linear voltage regulator controllers. The controllers use external transistors to generate 2 of the 3 required voltages: 1.9V (nominal) and 1.2V (nominal). These two voltages are stepped-down from a 3.3V source.

Table 21. 3.3V External Power Supply Parameters

Title	Description	Min	Max	Units
Rise Time	Time from 10% to 90% mark	2	200	ms
Monotonicity	Voltage dip allowed in ramp	-	300	mV
Slope	Ramp rate at any given time between 10% and 90% Min: $0.8 \cdot V(\text{min}) / \text{Rise time}(\text{max})$ Max: $0.8 \cdot V(\text{max}) / \text{Rise time}(\text{min})$	-	1500	mV/ms
Operational Range	Voltage range for normal operating conditions	3.0	3.6	V



Table 21. 3.3V External Power Supply Parameters

Title	Description	Min	Max	Units
Ripple	Maximum voltage ripple (peak to peak) ^a	-	100	mV
Overshoot	Maximum overshoot allowed	-	660	mV
Overshoot Settling Time	Maximum overshoot allowed duration. (At that time delta voltage should be lower than 5 mV from steady state voltage)	-	3	ms

a. The peak to peak output ripple is measured at 20 MHz Bandwidth within the operational range.

4.4.4 Internal LVR Power Sequencing

All supplies should rise monotonically. Sequencing of the supplies is controlled by the 82563EB/82564EB.

4.4.4.1 Power up Sequencing and Tracking

During power up, the sequencing and tracking of the internally controlled supplies (1.9V and 1.2V) is controlled by the 82563EB/82564EB. No specific motherboard requirements are necessary to prevent electrical overstress or latch-up.

- The 82563EB/82564EB analog voltage (1.9V) will never exceed the 3.3V supply at any time during the power up. This is because the 1.9V supply is generated from the 3.3V supply when using the internal voltage regulator control logic (see Figure 5 and Figure 6 for a schematic of the internal LVR circuit). The 1.9V supply will track the 3.3V ramp.
- The 82563EB/82564EB core voltage (1.2V) will never exceed the 3.3V at any time during the power up. This is because the 1.2V supply is generated from the 3.3V supply when using the internal voltage regulator control logic (see Figure 5 and Figure 6 for a schematic of the internal LVR circuit). The 1.2V ramp is delayed internally to prevent it from exceeding the 1.9V and 3.3V supply at any time. The delay is proportional to the slope of the 3.3V ramp.

The delay is approximated by $T_{\text{ramp}}(3.3\text{V}) * 0.25 < T_{\text{delay}}(1.2\text{V}) < T_{\text{ramp}}(3.3\text{V}) * 0.75$. T_{ramp} is defined to the ramp rate of the 3.3V input to the internal voltage regulator circuit.

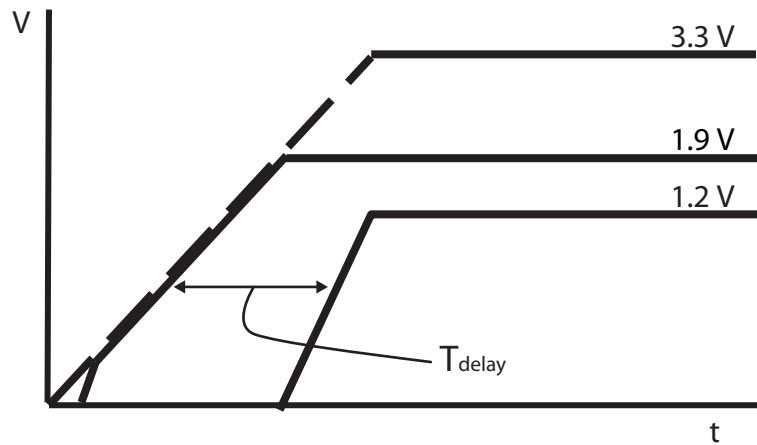

Figure 4. 82563EB/82564EB power up sequencing with internal regulators

4.4.4.2 Internal LVR Power down Sequencing

There are no specific power down sequencing and tracking requirements for the 82563EB/82564EB device. The risk of latch-up or electrical overstress is small because only the only charge storing in decoupling capacitors is left in the system.

4.4.4.3 82563EB/82564EB BOM for Internal Voltage Regulators

Table 22. 82563EB/82564EB BOM (Bill of Material) of Components for Internal Regulator

Description	Quantity	Recommended Component		
		Manufacturer	Part Number	Package
PNP Transistor For 1.2V LVR	1	Philips	BCP-69-16	SOT-223
PNP Transistor For 1.9V LVR	1	Philips	BCP-69-16	SOT-223



4.4.4.4 1.9V Internal LVR Specification

Table 23. 1.9V Internal LVR Specification

Parameter	Value		Units	Comments
	Minimum	Maximum		
Input Voltage	3.0	3.6	V	-
Input Capacitance	4.7	-	μ F	-
Input Capacitance ESR	-	100	M Ω	-
Load Current	1	-	A	$V_{OUT} = 1.900$ V
Output Voltage Tolerance	-5	+10	%	-
Output Capacitance	4.7	-	μ F	-
Output Capacitance ESR ^a	-	100	M Ω	-
Current Consumption during power up	-	0.5	mA	-
Current Consumption during power down	-	0.5	mA	-
Peak to Peak output Ripple ^b	-	100	mV	-
PSRR	-	20	dB	-
Turn-On Time	0.1	1	ms	-
External PNP hFE	100	N/A	-	-

a. The use of Tantalum capacitors is not recommended.

b. The peak to peak output rippled is measured at 20 MHz Bandwidth within the operational range.

4.4.4.5 1.2V Internal LVR Specification

Table 24. 1.2V Internal LVR Specification (Sheet 1 of 2)

Parameter	Value		Units	Comments
	Minimum	Maximum		
Input Voltage	3.0	3.6	V	-
Input Capacitance	4.7	-	μ F	-
Input Capacitance ESR	-	100	M Ω	-
Load Current	1	-	A	$V_{OUT} = 1.20$ V



Table 24. 1.2V Internal LVR Specification (Sheet 2 of 2)

Parameter	Value		Units	Comments
	Minimum	Maximum		
Output Voltage Tolerance	-10	+10	%	-
Output Capacitance	4.7	-	μF	-
Output Capacitance ESR ^a	-	100	M Ω	-
Current Consumption during power up	-	0.5	mA	-
Current Consumption during power down	-	0.5	mA	-
Peak to Peak output Ripple ^b	-	100	mV	-
PSRR	-	20	dB	-
Turn-On Time	0.1	1	ms	-
External PNP hFE	100	-	-	-

- a. The use of Tantalum capacitors is not recommended.
- b. The peak to peak output ripple is measured at 20 MHz Bandwidth within the operational range.

4.4.4.6 PNP Transistor Specification for Internal LVR

Table 25. PNP Specification

Title	Description	Min	Max	Units
$V_{ce,sat}$	Collector-emitter saturation voltage	-	0.5	V
$I_c(max)$	Collector current, maximum sustained	-	1000	mA
I_b	Base current, maximum sustained	-	10	mA
V_{be}	Base-emitter on voltage	-	1	V
T_{jmax}	Maximum junction temperature	-	150	°C
Power Dissipation	Maximum total power dissipation	-	1.35	W
hFE	DC Current gain	100	-	-
fT	Current Gain Product Bandwidth	10	-	MHz

4.4.4.7 Internal LVR Board Schematic

When using the internal voltage regulator controllers built into the 82563EB/82564EB, series resistors may need to be placed in series with the collector in order to prevent the PNP transistors from overheating. These series resistors dissipate a portion of the power that would otherwise be dissipated by the PNP devices. The value and power rating of the resistors must be carefully chosen to balance thermal limits against the PNP characteristics against total current draw. The regulator must never drop below the minimum V_{ce} and out of the linear region.



The effective resistance of the pass resistors should be approximately 0.5Ω and have a combined power dissipation rating of 0.5 Watts for the 82563EB. Figure 5 shows the recommended implementation.

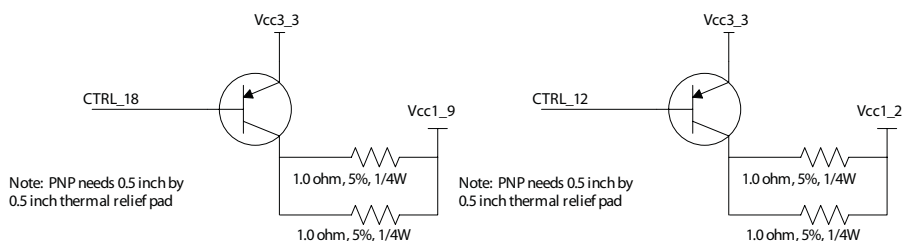

Figure 5. 82563EB 1.9V and 1.2V internal LVR schematic

Note: No resistors are required for the 82564EB as shown in Figure 6 due to the reduction in current demand. See Figure 4.9 for more details regarding power consumption.

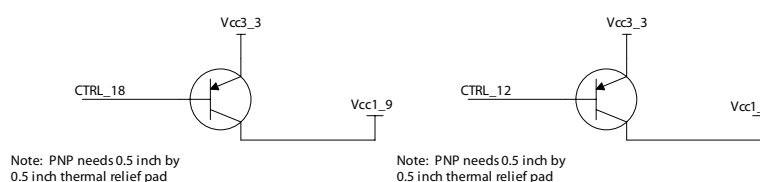

Figure 6. 82564EB 1.9V and 1.2V internal LVR schematic

4.5 Link (MDI) Interface

The Media Dependent Interface pins (MDIA_PLUS[3:0], MDIA_MINUS[3:0], MDIB_PLUS[3:0], MDIB_MINUS[3:0]) are analog pins conforming to the IEEE 802.3ab (802.3 Clause 40) requirements.

Table 26. Link (MDI) Interface Electrical Specification

Symbol	Parameter	Pins	Condition	Min	Typ	Max	Unit
V_{ODIFF}	Absolute peak differential output voltage	MDI*[1:0]	10Base-T no cable	2.2	2.5	2.8	V
		MDI*[1:0]	10Base-T cable	585 ^b	-	-	mV
		MDI*[1:0]	100Base-TX mode	0.950	1	1.050	V
		MDI*[3:0]	1000Base-T ^a	0.67	0.75	0.82	V
	Overshoot	MDI[1:0]	100Base-TX mode	0	-	5%	(V)
	Amplitude Symmetry (positive / negative)	MDI[1:0]	100Base-TX mode	0.98x	-	1.02x	V^+ / V^-



Table 26. Link (MDI) Interface Electrical Specification

Symbol	Parameter	Pins	Condition	Min	Typ	Max	Unit
V_{IDIFF}	Peak differential input voltage	MDI[1:0]	10Base-T	585 ^c	-	-	mV
	Signal Detect Assertion	MDI[1:0]	100Base-TX		460 ^d	1000	mV peak - peak
	Signal Detect De-assertion	MDI[1:0]	-	200	360 ^e		mV peak - peak

- a. IEEE 802.3ab Figure 40-19 points A&B.
- b. IEEE 802.3 Clause 14, Figure 14.9 shows the template for the “far end” wave form. This template allows as little as 495mV peak differential voltage at the far end receiver.
- c. See IEEE 802.3, Clause 14, Figure 14.17 for the template for the receive wave form.
- d. The ANSI TP-PMD specification requires that any received signal with peak-to-peak differential amplitude greater than 1000 mV should turn on signal detect. The 82563EB/82564EB will accept signals typically with 460 mV peak-to-peak differential amplitude.
- e. The ANSI TP-PMD specification requires that any received signal with peak-to-peak differential amplitude less than 200 mV should de-assert signal detect. The 82563EB/82564EB will reject signals typically with 360 mV peak-to-peak differential amplitude

4.6 Kumeran (Serial) Interface

The Kumeran interface is electrically compatible with the SERDES implemented in 1000Base-BX applications, as defined in the PICMG 3.1 Specification, Version 1.0, Chapter 5, Backplane Physical Layers Interfaces. It also implements electrical idle as described in section 3.5.4. As part of the electrical idle implementation, the Kumeran interface also needs to be able to detect when the 631xESB/632xESB is in electrical idle.

4.6.1 Transmit

The transmit specifications are measured with the following test load.

Table 27. Kumeran (Serial) Transmit Specifications

Symbol	Parameter	Min	Typ	Max	Unit	Notes
	Data Rate (original data)	999.9	1000	1000.1	Mb/s	1000 mb/s ± 100 ppm
	Signaling Speed (raw data rate of encoded data)	1249.875	1250	1250.125	V	1250 mb/s ± 100 ppm
	Clock Tolerance	-100	-	+100	ppm	
$V_{DIFFp-p}$	Differential Output Amplitude (peak to peak)	750	-	1350	mV	
V_{DIFFp}	Differential Output Amplitude (peak)	375	-	675	mV	Equivalent to $V_{DIFFp-p}$
	Return Loss	10	-	-	dB	
	Impedance at Connection	70	100	130	Ω	



The differential peak and differential peak to peak voltage is defined as follows:

- $V_{DIFFp} = \max(|V_+ - V_-|)$
- $V_{DIFFp-p} = (2 * V_{DIFFp})$

In addition, the transmitter must meet the following eye diagram.

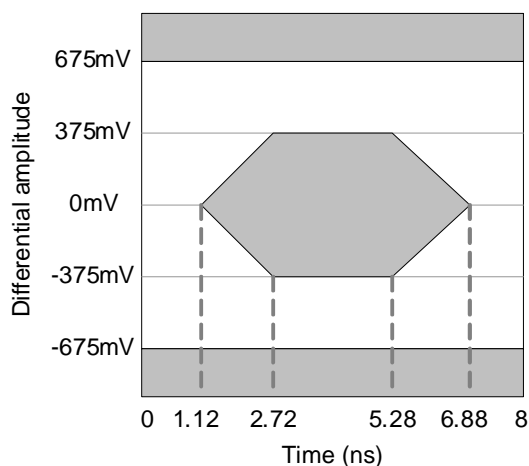

Figure 7. Kumeran (Serial) Transmit Eye Diagram

4.6.2 Receive

The receiver operates with less than 10^{-12} Bit Error Rate (BER) when the received signal meets valid voltage and timing specifications and is delivered from a balanced 100Ω source.

Table 28. Kumeran (Serial) Receive Specifications

Symbol	Parameter	Min	Typ	Max	Unit	Notes
	Data Rate (original data)	999.9	1000	1000.1	Mb/s	1000 mb/s \pm 100 ppm
	Signaling Speed (raw data rate of encoded data)	1249.875	1250	1250.125	V	1250 mb/s \pm 100 ppm
	Clock Tolerance	-100	-	+100	ppm	
$V_{SENSp-p}$	Sensitivity (differential peak to peak)	200	-	1350	mV	
V_{SENSp}	Sensitivity (differential peak)	100	-	675	mV	Equivalent to $V_{SENSp-p}$
	Differential Skew	-	-	175	ps	
	Differential Return Loss	10	-	-	Ω	



Table 28. Kumeran (Serial) Receive Specifications

Symbol	Parameter	Min	Typ	Max	Unit	Notes
	Common Mode Return Loss	6	-	-	dB	
	TDR Rise	-	85	-	Ω	
	Impedance at Connection	70	100	130		

Note: TDR measurements are recorded times. Record time = TDR transmit time *2.

The receiver expects to receive a signal meeting the following eye diagram.

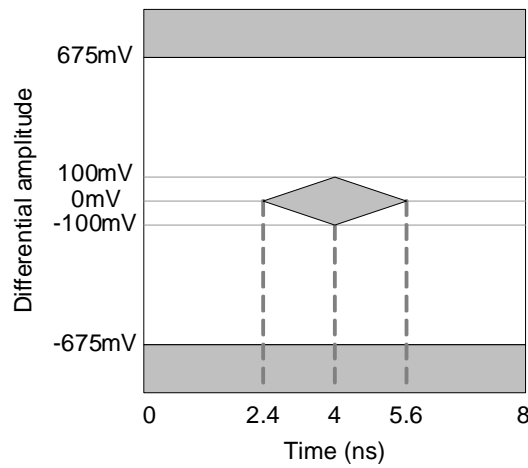

Figure 8. Kumeran (Serial) Receive Eye Diagram

4.6.3 Electrical Idle

The Kumeran interface also implements electrical idle. As a result, it needs to:

- Detect when the 631xESB/632xESB has gone into electrical idle
- Go into electrical idle



4.6.3.1 Electrical Idle Detection

The 82563EB/82564EB detects that the 631xESB/632xESB has gone into electrical idle when it senses that the differential voltage has gone below and is remaining below a threshold voltage.

Table 29. Kumeran (Serial) Electrical Idle Detection

Symbol	Parameter	Min	Typ	Max	Unit
$V_{RX_IDLE_DET_DIFFp-p}$	Voltage range to detect electrical idle (differential peak to peak)	65	-	200	mV
$V_{RX_IDLE_DET_DIFFp}$	Voltage range to detect electrical idle (differential peak to peak)	37.5	-	100	mV

Note: When the differential peak to voltage is below 65 mV (37.5 mV differential peak), the 82563EB/82564EB detects that the 631xESB/632xESB has gone into electrical idle. This voltage corresponds to the minimum output voltage in Electrical Idle plus some noise margin.

When the differential peak to peak voltage is above 200 mV (100 mV differential peak), the 82563EB/82564EB detects that the 631xESB/632xESB is not in electrical idle. This voltage corresponds to the minimum valid receive level.

4.6.3.2 Electrical Idle Output

The following parameters relate to electrical idle output and the transition into and out of electrical idle.

Table 30. Kumeran (Serial) Electrical Idle Output

Symbol	Parameter	Min	Typ	Max	Unit
$V_{TX_IDLE_DIFFp}$	Electrical Idle peak output voltage.	0	-	20	mV
$V_{TX_IDLE_MON}$	Minimum time spent in electrical idle.	400	-	100	mV
$V_{TX_IDLE_SET_TO_IDLE}$	Maximum time for to transition to a valid electrical idle after electrical idle detected.			1	ms
$T_{TX_IDLE_TO-DIFF-DATA}$	Maximum time to transition to valid transmit after leaving electrical idle.			340	μ s



4.7 Crystal

The quartz crystal is strongly recommended as a low cost and high performance choice with the 82563EB/82564EB device. Quartz crystals are the mainstay of frequency control components and are available from numerous vendors in many package types with various specification options

Table 31. Crystal Parameters

Parameter	Suggested Value	Conditions
Vibrational Mode	Fundamental	
Nominal Frequency	25.000 MHz	at 25° C
Frequency Tolerance	<ul style="list-style-type: none">±30 ppm recommended±50 ppm across the entire operating temperature range (required by IEEE specifications)	at 25° C
Temperature Tolerance	±30 ppm	at 0° C to 70° C
Calibration Mode	Parallel	
Load Capacitance	27 pF	
Shunt Capacitance	6 pF maximum	
Equivalent Series Resistance	50 Ω maximum	at 25 MHz
Drive Level	750 μW	
Aging	±5 ppm per year maximum	

4.7.1 External Clock Oscillator

If using an external oscillator to provide a clock to the 82563EB/82564EB, the connection shown in Figure 9 must be used. Note that the XTAL2 output of the 82563EB/82564EB must not be connected. The XTAL1 input receives the output of the oscillator directly; AC coupling is not recommended.

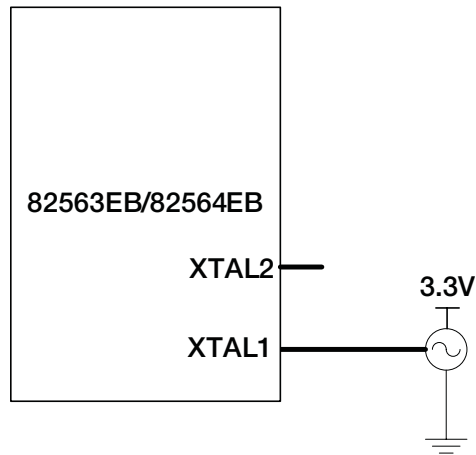

Figure 9. External Clock Oscillator Connectivity to 82563EB/82564EB



Table 32. Specification for External Clock Oscillator

Parameter Name	Symbol	Value	Conditions
Frequency	f_o	25.0 [MHz]	@25 [°C]
Swing	V_{p-p}	3.3 ± 0.3 [V]	-
Frequency Tolerance	$\Delta f/f_o$	± 30 [ppm]	-0 to +70 [°C]
Operating Temperature	T_{opr}	-0 to +70 [°C]	-
Aging	$\Delta f/f_o$	± 5 ppm per year	-

4.8 Reset and Initial Clock Timing

PHY_PWR_GOOD must be low throughout the time that the power supplies are ramping. This guarantees that the 82563EB/82564EB resets cleanly.

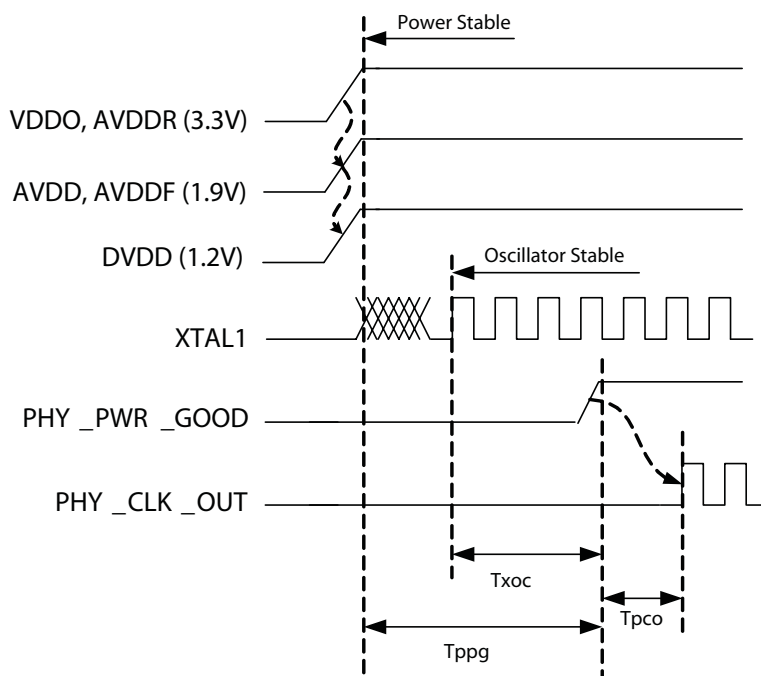

Figure 10. 82563EB/82564EB Reset Timing



Table 33. Reset Specification

Title	Description	Min	Max	Units
PHY_PWR_GOOD pulse	Minimum pulse width for LAN_PWR_GOOD	100	-	μs
T _{ppg}	Minimum time PHY_PWR_GOOD must be low after power supply is in operating range	100	-	μs
T _{xoc}	Time from oscillator stable to PHY_PWR_GOOD assertion, when using an external oscillator.	100	-	μs
T _{pco}	Time from PHY_PWR_GOOD assertion until the 82563EB/82564EB outputs the PHY_CLK_OUT.	-	350	μs

There are no required timing relationships between PHY_RESET_N, PHY_SLEEP, and either PHY_PWR_GOOD, the power supply being stable, or the oscillator being stable. The 82563EB/82564EB will come out of reset when both PHY_PWR_GOOD is asserted (1b) and PHY_RESET_N is deasserted (1b). It will be active when PHY_PWR_GOOD is asserted (1b), PHY_RESET_N is deasserted (1b), and PHY_SLEEP is deasserted (0b).

4.9 Power Consumption

The 82563EB/82564EB's power consumption (Tables 34 through 37) is the sum of each port's power consumption. A port's power consumption depends on whether the port's logic, PHY, and Kumeran are operational, and the 82563EB/82564EB's operating speeds. These in turn, depend on the following factors:

PHY_PWR_GOOD input	Powers off the entire chip (including PHY_CLK_OUT) when 0b. It has priority over PHY_RESET_N or PHY_SLEEP.
PHY_RESET_N input	When 0b, the entire chip is held in reset except PHY_CLK_OUT.
PHY_SLEEP input	When 1b the entire chip is powered down, except PHY_CLK_OUT.
Port Disable Register	The port's PHY and Kumeran can be disabled by writing a 1b to the "Disable Port" bit of the "Power Management Control" register.
PHY Power Down	The 82563EB/82564EB can be powered down with an indication over the Kumeran bus or by writing a 1b to the "Control Register's" "Power Down" bit.
Link Down	When the link is required but the link is down the 82563EB/82564EB remains in energy detect mode, attempting to detect energy from the link partner.
Speed	The 82563EB/82564EB uses progressively more power as the speed increases from 10 Mb/s to 100 Mb/s to 1000 Mb/s. Speed is normally based on auto-negotiation with the link partner, but may be forced or influenced by the power state.
Power State	The power state can be used in conjunction with the "Low Power Link Up" and "Auto-Negotiation 1000 Disable" to control the 82563EB/82564EB's speed.
Kumeran Electrical Idle	Nothing is transmitted on the differential pairs.



Table 34. Power Supply Characteristics - D0a (Both Ports)

	D0a (Both Ports)							
	Unplugged/No Link		10 Mb/s Operation		100 Mb/s Operation		1000 Mb/s Operation	
	Typ Icc (mA)	Max Icc (mA)	Typ Icc (mA)	Max Icc (mA)	Typ Icc (mA)	Max Icc (mA)	Typ Icc (mA)	Max Icc (mA)
3.3 V	12	47	20	22	22	23	35	36
1.9 V	11	11	33	33	79	79	411	411
1.2 V	20	26	140	140	165	165	345	345
Total Device Power	145 mW		635 mW		878 mW		2610 mW	

Table 35. Power Supply Characteristics - D3cold - Wake Up Enabled (Both Ports)

	D3cold - Wake Up Enabled (Both Ports)						D3cold - Wake Up Disabled (Both Ports)	
	Unplugged/No Link		10 Mb/s Operation		100 Mb/s Operation		Typ Icc (mA)	Max Icc (mA)
	Typ Icc (mA)	Max Icc (mA)	Typ Icc (mA)	Max Icc (mA)	Typ Icc (mA)	Max Icc (mA)		
3.3 V	12	47	21	22	22	23	12	12
1.9 V	11	11	33	33	79	79	11	11
1.2 V	20	26	140	140	166	166	12	12
Total Device Power	145 mW		640 mW		879 mW		115 mW	

Table 36. Power Supply Characteristics - Uninitialized/Disabled

	Uninitialized/Disabled			
	D(n) Uninitialized (PHY PWR GOOD = 0b)		Disabled ^a (via Flash Address)	
	Typ Icc (mA)	Max Icc (mA)	Typ Icc (mA)	Max Icc (mA)
3.3 V	10	13	11	13
1.9 V	18	20	19	19
1.2 V	2	2	7	12
Total Device Power	116 mW		120 mW	

a. Equivalent to PHY_SLEEP = 1b and/or PHY_RESET_N = 0b.



Table 37. Power Supply Characteristics - Complete Subsystem

	Complete Subsystem (Including Magnetics, LED, and Regulator Circuits)					
	10 Mb/s Operation		100 Mb/s Operation		1000 Mb/s Operation	
	Typ Icc	Max Icc	Typ Icc	Max Icc	Typ Icc	Max Icc
3.3 V	27	28	35	37	60	63
1.9 V	33	33	78	79	413	413
1.2 V	280	280	220	220	704	704
Subsystem 3.3 V Current	1121 mW		1107 mW		3883 mW	4248 mW



Note: This page intentionally left blank.



5.0 Package and Pinout Information

This section describes the 82563EB/82564EB device physical characteristics. The pin number-to-signal mapping is indicated beginning with Section 5.3.

5.1 Package Information

The package used for the 82563EB/82564EB is a 100-pin, 14 mm x 14 mm TQFL with an Exposed-Pad*. An Exposed-Pad* is a central pad on the bottom of the package that serves as a ground and thermal connection.

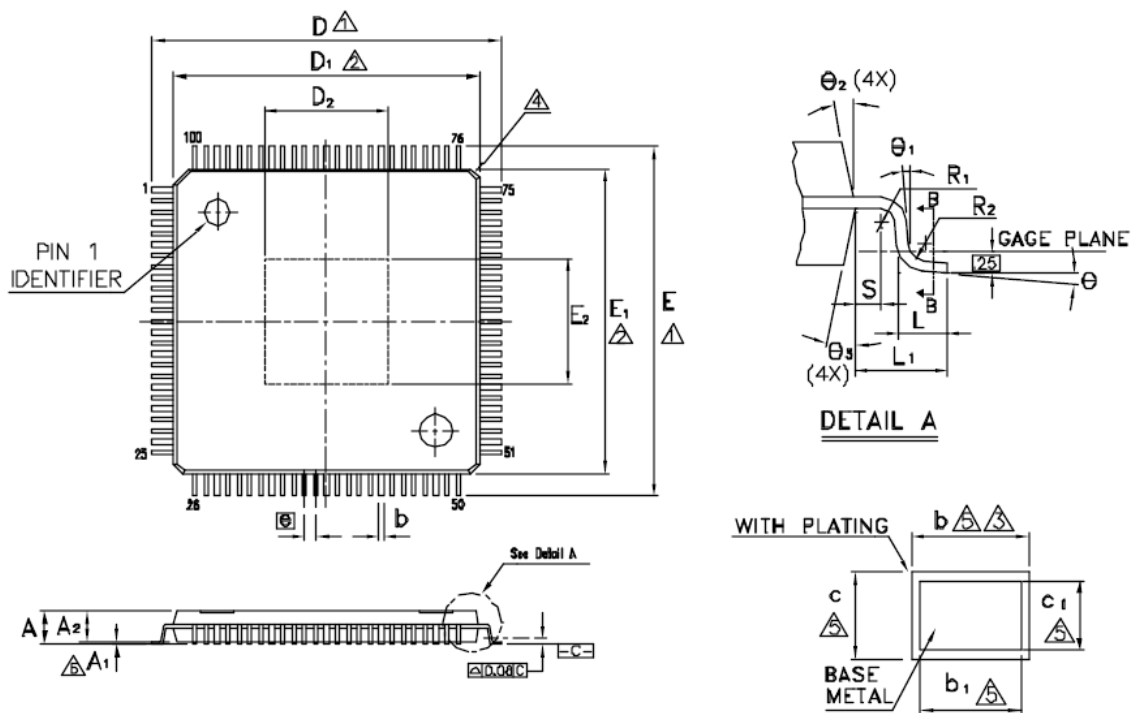

Figure 11. Mechanical Information



Symbol	Dimension in mm			Dimension in inch		
	Min	Norm	Max	Min	Norm	Max
A	—	—	1.20	—	—	0.047
A ₁	0.05	—	0.15	0.002	—	0.006
A ₂	0.95	1.00	1.05	0.037	0.039	0.041
b	0.17	0.22	0.27	0.007	0.009	0.011
b ₁	0.17	0.20	0.23	0.007	0.008	0.009
c	0.09	—	0.20	0.004	—	0.008
c ₁	0.09	—	0.18	0.004	—	0.630
D	16.00 BSC			0.630 BSC		
D ₁	14.00 BSC			0.551 BSC		
E	16.00 BSC			0.630 BSC		
E ₁	14.00 BSC			0.551 BSC		
ⓐ	0.50 BSC			0.020 BSC		
L	0.45	0.60	0.75	0.018	0.024	0.030
L ₁	1.00 REF			0.039 REF		
R ₁	0.08	—	—	0.003	—	—
R ₂	0.08	—	0.20	0.003	—	0.008
S	0.20	—	—	0.008	—	—
θ	0°	3.5°	7°	0°	3.5°	7°
θ ₁	0°	—	—	0°	—	—
θ ₂	11°	12°	13°	11°	12°	13°
θ ₃	11°	12°	13°	11°	12°	13°

Die Pad Size Options			
Option	Symbol	Dimension in mm	Dimension in inch
Option #1	D ₂	5.72 BSC	.225 BSC
	E ₂	5.72 BSC	.225 BSC
Option #2	D ₂		
	E ₂		

NOTE :

- ⚠ TO BE DETERMINED AT SEATING PLANE \square .
 - ⚠ DIMENSIONS D1 AND E1 DO NOT INCLUDE MOLD PROTRUSION. D1 AND E1 ARE MAXIMUM PLASTIC BODY SIZE DIMENSIONS INCLUDING MOLD MISMATCH.
 - ⚠ DIMENSION b DOES NOT INCLUDE DAMBAR PROTRUSION. DAMBAR CAN NOT BE LOCATED ON THE LOWER RADIUS OR THE FOOT.
 - ⚠ EXACT SHAPE OF EACH CORNER IS OPTIONAL.
 - ⚠ THESE DIMENSIONS APPLY TO THE FLAT SECTION OF THE LEAD BETWEEN 0.10 mm AND 0.25 mm FROM THE LEAD TIP.
 - ⚠ A1 IS DEFINED AS THE DISTANCE FROM THE SEATING PLANE TO THE LOWEST POINT OF THE PACKAGE BODY.
7. CONTROLLING DIMENSION : MILLIMETER.

Figure 12. Mechanical Specifications and Notes



5.2 Thermal Specifications

The 82563EB/82564EB device is specified for operation when the ambient temperature (T_A) is within the range of 0° C to 60° C.

The maximum junction temperature is 120° C. The maximum ambient temperature with airflow and/or a heatsink can be calculated using the thermal coefficient data below and the power specification (see section 4.7)

T_C (case temperature) is calculated using the equation:

$$T_C = T_A + P (\theta_{JA} - \theta_{JC})$$

T_J (junction temperature) is calculated using the equation:

$$T_J = T_A + P \theta_{JA}$$

P (power consumption) is calculated by using the typical I_{CC} , as indicated in Table 38, and nominal V_{CC} . The preliminary thermal resistances are shown in Table 38.

Table 38. Thermal Characteristics

Symbol	Parameter	Value @ Given Airflow (m/s)				Units
		0	1	2	3	
θ_{JA}	Thermal Resistance, Junction to Ambient	26.1	22.9	21.7	21.1	°C/watt
θ_{JC}	Thermal Resistance, Junction to Case	12.7	-	-	-	°C/watt



5.3 Pinout Information

Table 39. 82563EB/82564EB Pinout by Pin Number Order (Sheet 1 of 3)

Pin	82563EB Dual Port	82564EB Single Port ^a	External Strapping ^b
1	JTAG_TDI	-	1 - 10 K Ω , 5%, p/u
2	DVDD	-	-
3	JTAG_TMS	-	1 - 10 K Ω , 5%, p/u
4	RESERVED_NC	-	-
5	RESERVED_NC	-	-
6	RESERVED_NC	-	-
7	DVDD	-	-
8	RESERVED_NC	-	-
9	RESERVED_NC	-	-
10	RESERVED_NC	-	-
11	VDDO	-	-
12	DVDD	-	-
13	RESERVED_NC	-	-
14	RESERVED_NC	-	-
15	RESERVED_NC	-	-
16	DVDD	-	-
17	RESERVED_NC	-	-
18	MDIO_ADD[2]	-	1 - 10 K Ω , 5%, p/d
19	MDIO_ADD[3]	-	1 - 10 K Ω , 5%, p/d
20	XTAL2	-	-
21	XTAL1	-	-
22	VDDO	-	-
23	CTRL_12	-	-
24	AVDDR	-	-
25	CTRL_18	-	-
26	RESERVED_NC	-	-
27	MDIA_PLUS[0]	-	-
28	MDIA_MINUS[0]	-	-
29	AVDD	-	-
30	AVDD	-	-
31	MDIA_PLUS[1]	-	-
32	MDIA_MINUS[1]	-	-
33	MDIA_PLUS[2]	-	-
34	MDIA_MINUS[2]	-	-



Table 39. 82563EB/82564EB Pinout by Pin Number Order (Sheet 2 of 3)

Pin	82563EB Dual Port	82564EB Single Port ^a	External Strapping ^b
35	AVDD	-	-
36	MDIA_PLUS[3]	-	-
37	MDIA_MINUS[3]	-	-
38	MDIB_MINUS[3]	RESERVED_NC	-
39	MDIB_PLUS[3]	RESERVED_NC	-
40	AVDD	-	-
41	MDIB_MINUS[2]	RESERVED_NC	-
42	MDIB_PLUS[2]	RESERVED_NC	-
43	MDIB_MINUS[1]	RESERVED_NC	-
44	MDIB_PLUS[1]	RESERVED_NC	-
45	AVDD	-	-
46	AVDD	-	-
47	MDIB_MINUS[0]	RESERVED_NC	-
48	MDIB_PLUS[0]	RESERVED_NC	-
49	RESERVED_NC	-	-
50	PHY_REF	-	4.99 K Ω , 1%, p/d
51	AVDDR	-	-
52	RESERVED_NC	-	-
53	RESERVED_NC	-	-
54	LINK_B	-	See Table 10
55	LEDB_RX_ACTIVITY	RESERVED_NC	test point
56	LEDB_TX_ACTIVITY	RESERVED_NC	-
57	LEDB_DUPLEX	RESERVED_NC	-
58	LEDB_SPEED_1000_N	RESERVED_NC	-
59	DVDD	-	-
60	VDDO	-	-
61	LEDB_SPEED_100_N	RESERVED_NC	-
62	LEDB_ACTIVITY_N	RESERVED_NC	-
63	LEDB_LINK_UP_N	RESERVED_NC	-
64	DVDD	-	-
65	LINK_A	-	See Table 10
66	LEDA_RX_ACTIVITY	-	test point
67	LEDA_TX_ACTIVITY	-	-
68	LEDA_DUPLEX	-	-
69	DVDD	-	-
70	LEDA_SPEED_1000_N	-	-
71	LEDA_SPEED_100_N	-	-



Table 39. 82563EB/82564EB Pinout by Pin Number Order (Sheet 3 of 3)

Pin	82563EB Dual Port	82564EB Single Port ^a	External Strapping ^b
72	LEDA_ACTIVITY_N	-	-
73	LEDA_LINK_UP_N	-	-
74	DVDD	-	-
75	VDDO	-	-
76	MDIO	-	-
77	MDC	-	1 - 10 K Ω , 5% p/d
78	MDIO_ADD[0]	-	1 - 10 K Ω , 5% p/d
79	MDIO_ADD[1]	-	1 - 10 K Ω , 5% p/d
80	PHY_SLEEP	-	1 - 10 K Ω , 5% p/d
81	PHY_RESET_N	-	1 - 10 K Ω , 5% p/u
82	RESERVED_PD	-	1 - 10 K Ω , 5% p/d
83	PHY_PWR_GOOD	-	-
84	RXB_MINUS	RESERVED_NC	-
85	RXB_PLUS	RESERVED_NC	-
86	AVDDF	-	-
87	TXB_MINUS	RESERVED_NC	-
88	TXB_PLUS	RESERVED_NC	-
89	VSS	-	-
90	TXA_PLUS,	-	-
91	TXA_MINUS	-	-
92	AVDDF	-	-
93	RXA_PLUS,	-	-
94	RXA_MINUS	-	-
95	TEST_JTAG	-	1 - 10 K Ω , 5% p/u
96	PHY_CLK_OUT	-	-
97	VDDO	-	-
98	RESERVED_NC	-	-
99	JTAG_TDO	-	-
100	JTAG_TCK	-	1 - 10 K Ω , 5%,p/d
Central Pad	VSS	-	-

- a. The 82564EB device uses the same name as the 82563EB device unless otherwise specified.
b. For those external strappings that state 1 - 10 K Ω , 5%, the recommended value within that range is 3.3 K Ω , 5%.



5.4 Interface Diagrams

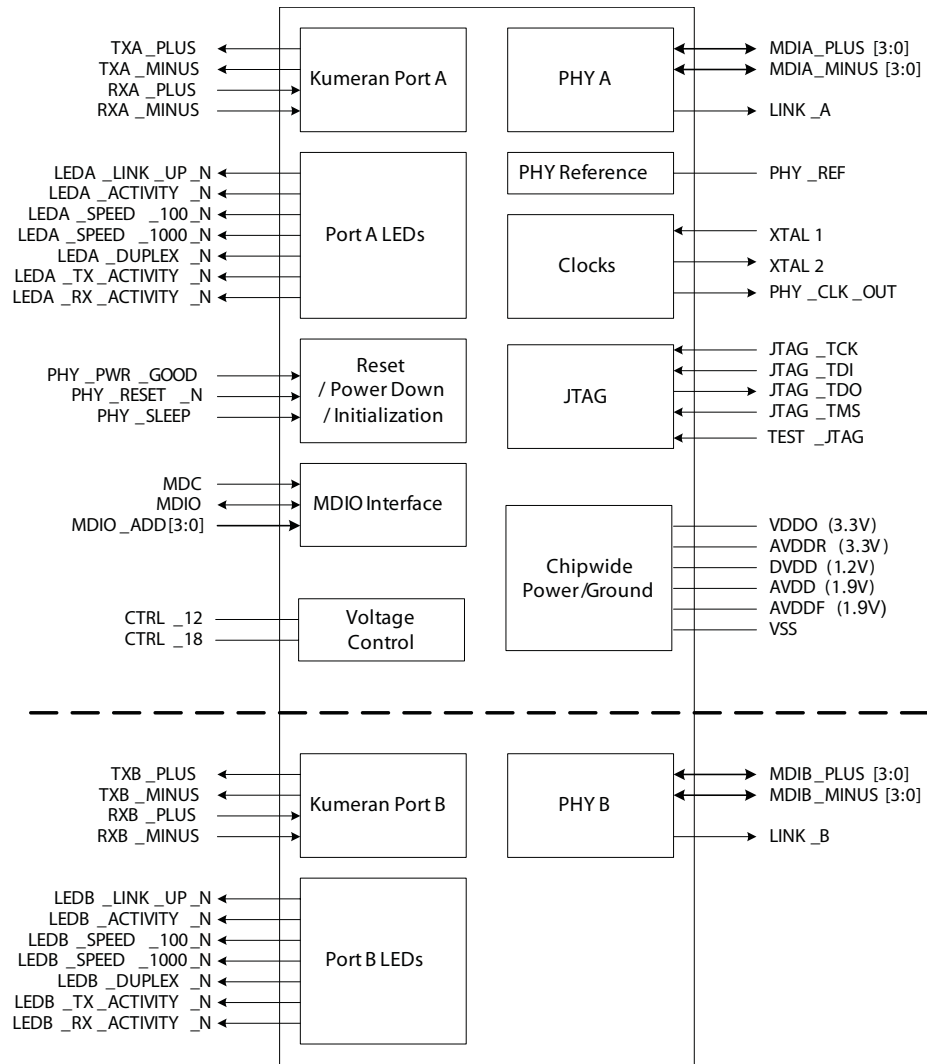

Figure 13. 82563EB/82564EB Interfaces



5.5 Visual Pin Assignments

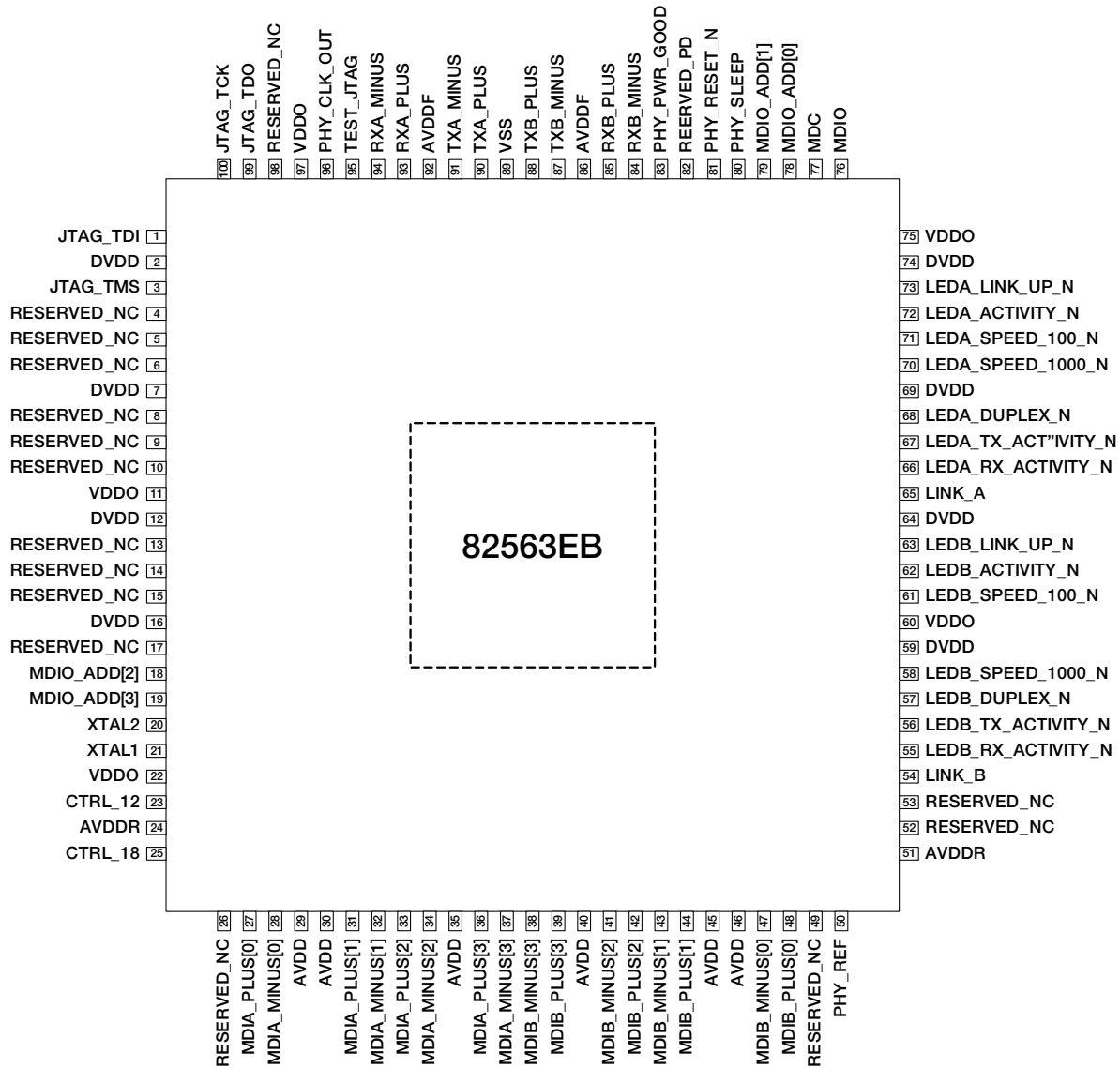

Figure 14. 82563EB Dual Port Gigabit Platform LAN connect Pinout (Top View)

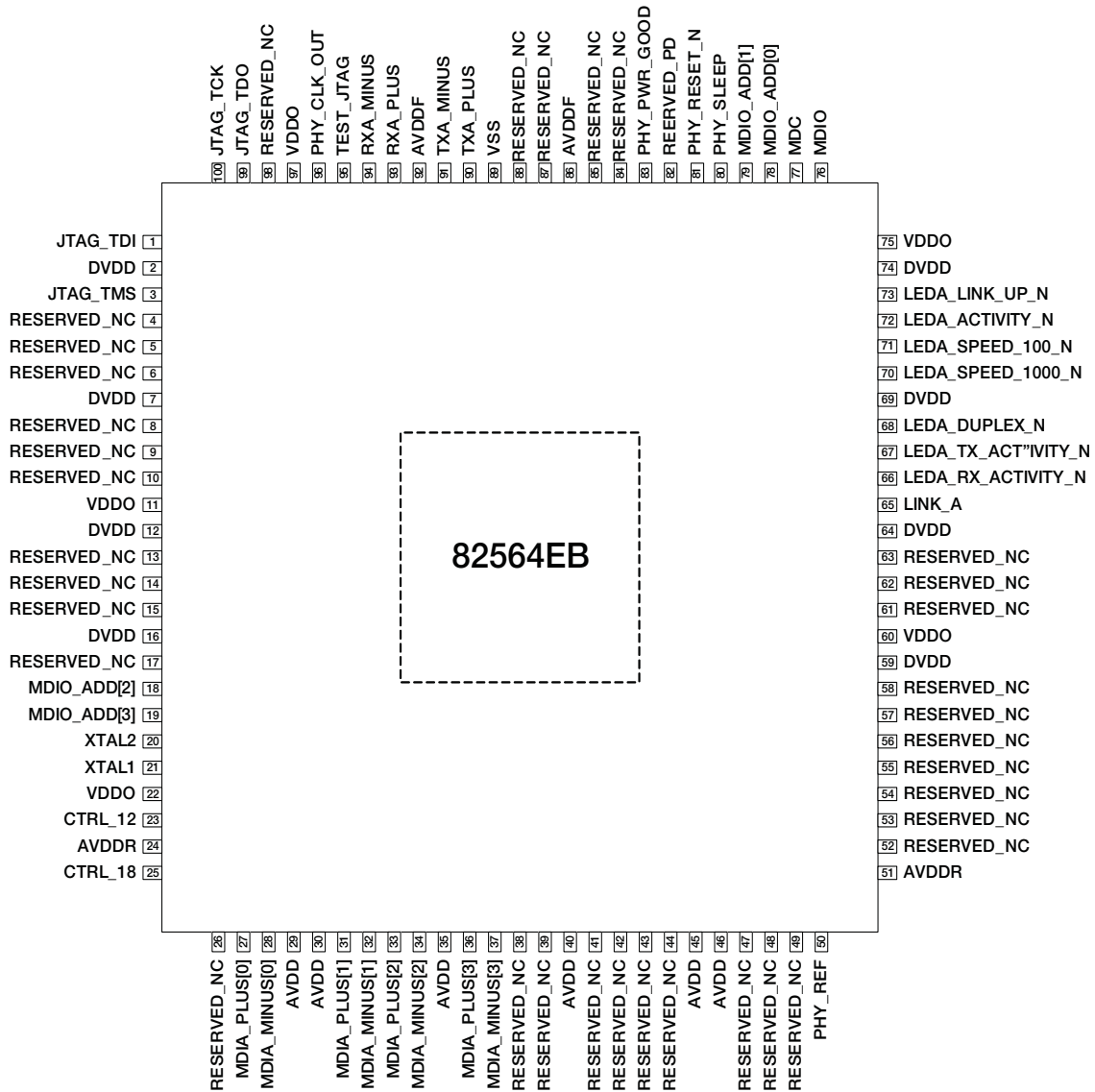

Figure 15. 82564EB Single Port Gigabit Platform LAN Connect Pinout (Top View)



Note: This page is intentionally left blank.

Данный компонент на территории Российской Федерации

Вы можете приобрести в компании MosChip.

Для оперативного оформления запроса Вам необходимо перейти по данной ссылке:

<http://moschip.ru/get-element>

Вы можете разместить у нас заказ для любого Вашего проекта, будь то серийное производство или разработка единичного прибора.

В нашем ассортименте представлены ведущие мировые производители активных и пассивных электронных компонентов.

Нашей специализацией является поставка электронной компонентной базы двойного назначения, продукции таких производителей как XILINX, Intel (ex.ALTERA), Vicor, Microchip, Texas Instruments, Analog Devices, Mini-Circuits, Amphenol, Glenair.

Сотрудничество с глобальными дистрибьюторами электронных компонентов, предоставляет возможность заказывать и получать с международных складов практически любой перечень компонентов в оптимальные для Вас сроки.

На всех этапах разработки и производства наши партнеры могут получить квалифицированную поддержку опытных инженеров.

Система менеджмента качества компании отвечает требованиям в соответствии с ГОСТ Р ИСО 9001, ГОСТ РВ 0015-002 и ЭС РД 009

Офис по работе с юридическими лицами:

105318, г.Москва, ул.Щербаковская д.3, офис 1107, 1118, ДЦ «Щербаковский»

Телефон: +7 495 668-12-70 (многоканальный)

Факс: +7 495 668-12-70 (доб.304)

E-mail: info@moschip.ru

Skype отдела продаж:

moschip.ru

moschip.ru_4

moschip.ru_6

moschip.ru_9