

# OEM LCC Sockets

32, 68 & 84 Leads

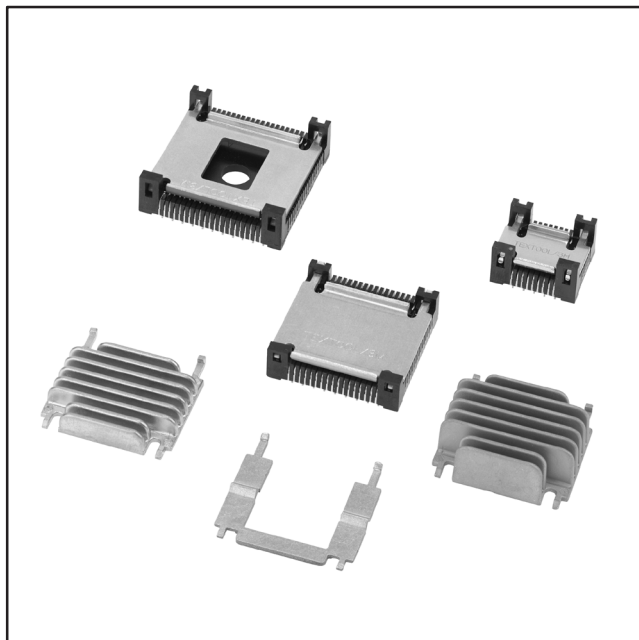

- Accepts JEDEC leadless ceramic chip carriers
- Variety of lid options available only for 68 position
- "U" lid for I.C.E. adaptor I/O cable exit
- Heat Sink available for 68 position
- Polarizing post on bottom of socket
- No tools required for package insertion/removal
- Full contact probe-ability
- High temperature PPS plastic and BeCu contacts for rugged performance

Date Issued: February 22, 2001

TS-0359-06  
Sheet 1 of 5

---

## Physical

### Insulation

Material: Glass Filled Polyphenylene Sulfide ( PPS )  
Flammability: UL 94V-0  
Color: Black

### Contact

Material: Beryllium Copper  
Plating: 50  $\mu$ " [ 1.27  $\mu$ m ] Nickel with Gold Flash in wiping area and solder tails

**Lid Material:** Aluminum

**Marking:** Raised Letters: 3M Logo & Part Identification

---

## Electrical

**Current Rating:** 1 A

**Insulation Resistance:** > 1  $\times 10^{12}$   $\Omega$  at 500 Vdc

**Withstanding Voltage:** 1000 Vrms at Sea Level

---

## Environmental

**Temperature Rating Operating:** - 55° C to +105° C

UL File No.: E68080

---

### 3M Electronic Handling and Protection

6801 River Place Blvd.  
Austin, TX 78726-9000

For technical, sales or ordering information call **800-328-0411**  
or visit our website: <http://www.3M.com/ehpd>

# OEM LCC Sockets

## 32, 68 & 84 Leads

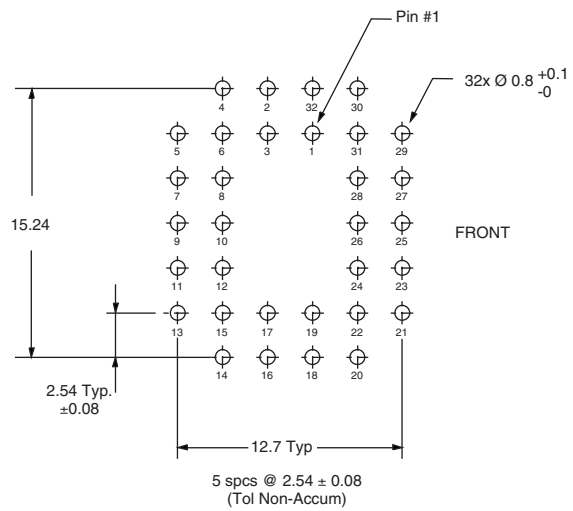
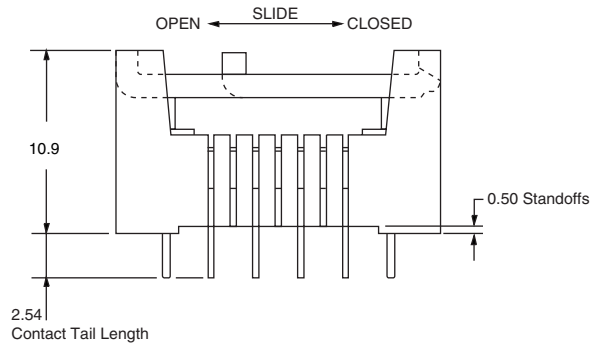
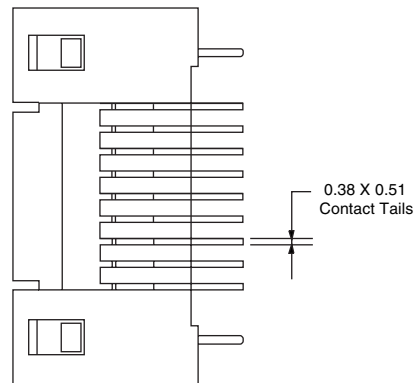
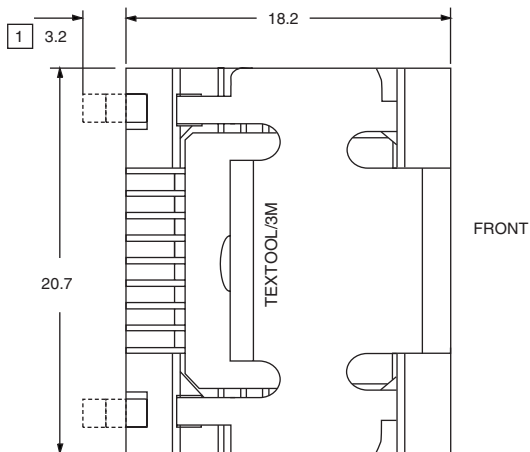

DIMENSIONS IN MILLIMETERS		
DIM	.0	.00
TOL	±0.25	±0.13

Notes:

1 Clearance required to allow for slide lid.

### Ordering Information

Lead Count	Part Number	Description	Device Thickness		
			Length	Width	Thickness*
32	232-1271-00-1102JH	Solid Lid			

\*Device Thickness does not include cover.

TS-0359-06  
Sheet 2 of 5

### 3M Electronic Handling and Protection Division

6801 River Place Blvd.  
Austin, TX 78726-9000

For technical, sales or ordering information call **800-328-0411**  
or visit our website: <http://www.3M.com/ehpd>

# OEM LCC Sockets

## 32, 68 & 84 Leads

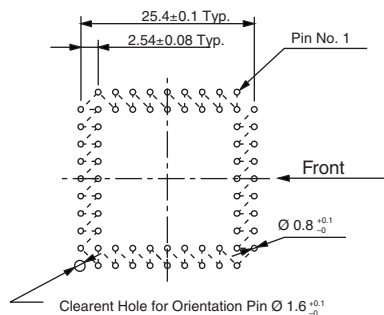
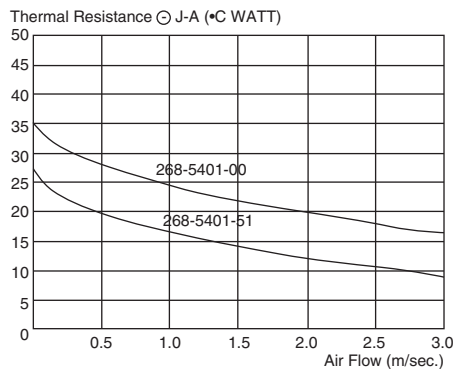
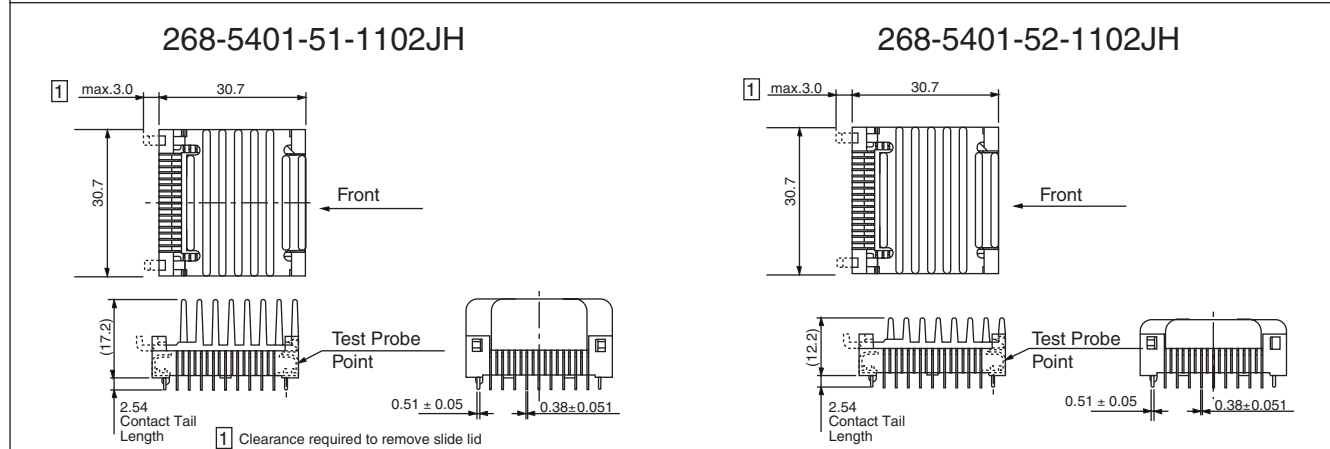
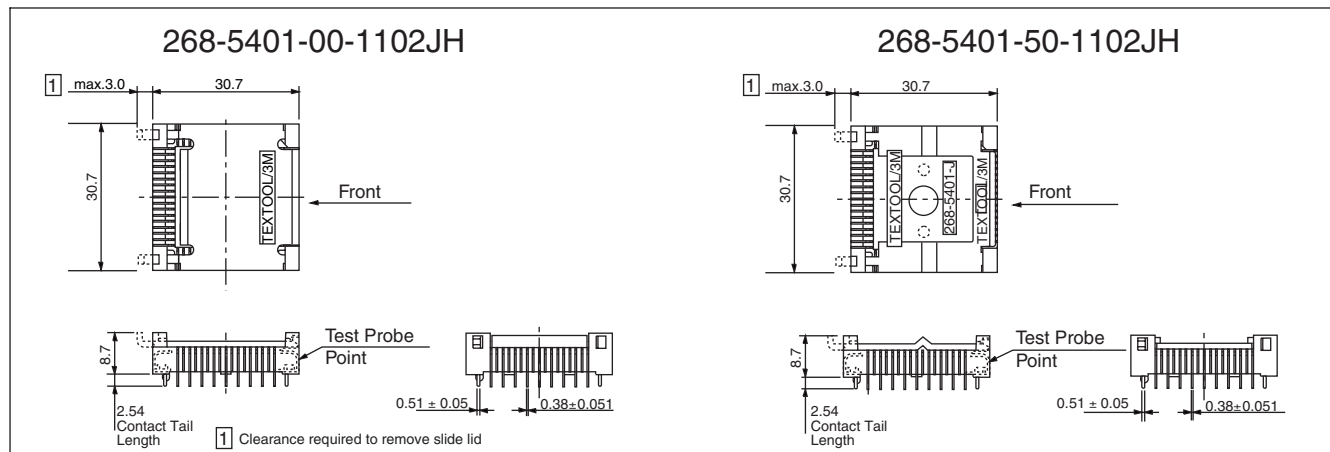

DIMENSIONS IN MILLIMETERS		
DIM	.0	.00
TOL	±0.25	±0.13

## Ordering Information

Lead Count	Part Number	Description	Applicable Device	
			Body Size	Thickness
68	268-5401-00-1102JH	Chip Carrier-LCC with Full Lid	24.13 ± 0.25	1.52 ± 0.15
68	268-5401-00-0000	Lid - Full	24.13 ± 0.25	1.52 ± 0.15
68	268-5401-11-1102JH	End Use-LCC Type "A" Base Sub-assembly	24.13 ± 0.25	1.52 ± 0.15
68	268-5401-50-0000	Lid-U Shape	24.13 ± 0.25	1.52 ± 0.15
68	268-5401-50-1102JH	Chip Carrier-LCC with U-Shape Lid	24.13 ± 0.25	1.52 ± 0.15
68	268-5401-51-0000	Lid - 11 mm Heat Sink	24.13 ± 0.25	1.52 ± 0.15
68	268-5401-51-1102JH	Chip Carrier-LCC with 11 mm Heat Sink	24.13 ± 0.25	1.52 ± 0.15
68	268-5401-52-0000	Lid - 6 mm Heat Sink	24.13 ± 0.25	1.52 ± 0.15
68	268-5401-52-1102JH	Chip Carrier-LCC with 6 mm Heat Sink	24.13 ± 0.25	1.52 ± 0.15

TS-0359-06  
Sheet 3 of 5

## 3M Electronic Handling and Proteciton Division

6801 River Place Blvd.  
Austin, TX 78726-9000

For technical, sales or ordering information call **800-328-0411**  
or visit our website: <http://www.3m.com/ehpd>

# OEM LCC Sockets

## 32, 68 & 84 Leads

### 284-1273-00

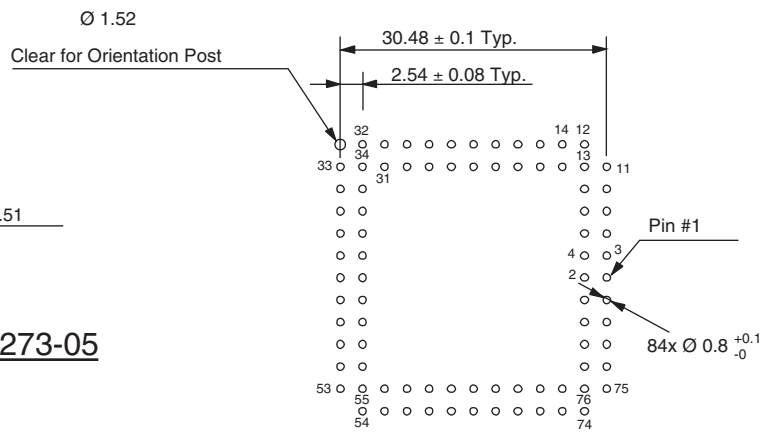
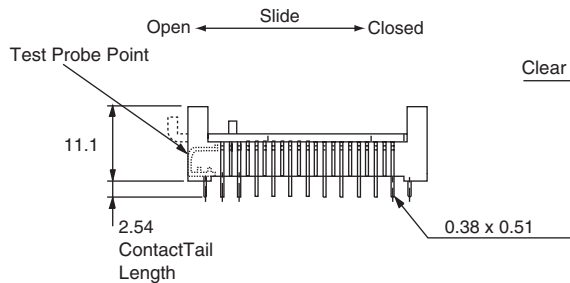
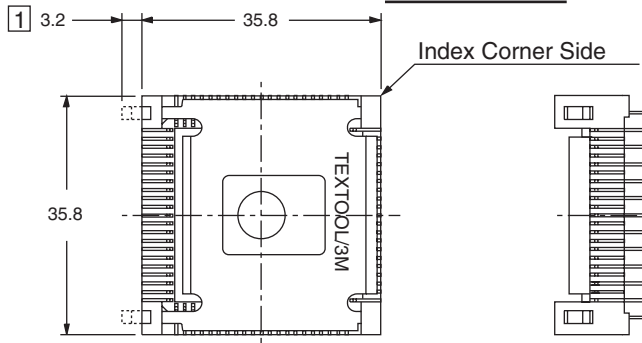

**P. C. Board Pattern**

### 284-1273-05

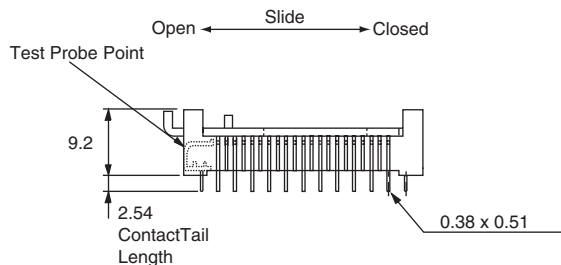
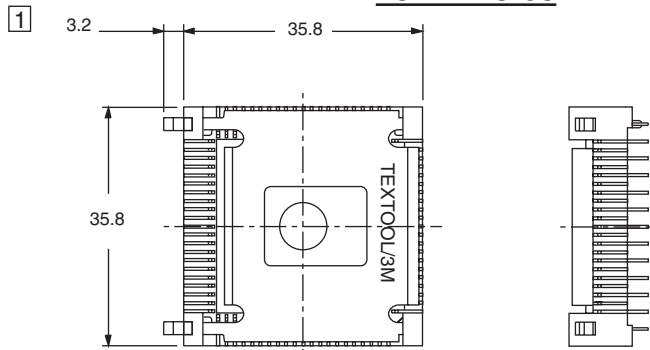

Notes:

- 1 Clearance required to remove slide lid.

DIMENSIONS IN MILLIMETERS		
DIM	.0	.00
TOL	±0.25	±0.13

## Ordering Information

Lead Count	Part Number	Applicable Device	
		Body Size	Thickness*
84	284-1273-00-1102JH	29.21 ± 0.38 Sq	3.40 ± 0.05
84	284-1273-05-1102JH	29.21 ± 0.28 Sq	1.52 ± 0.05

\* Device thickness does not include cover.

TS-0359-06  
4 of 5 Sheet

## 3M Electronic Handling and Protection Division

6801 River Place Blvd.  
Austin, TX 78726-9000

For technical, sales or ordering information call 800-328-0411  
or visit our website: <http://www.3M.com/ehpd>

# OEM LCC Sockets

## 32, 68 & 84 Leads

### Assembly Instructions:

- 1 Remove Lid from the socket body.
- 2 Insert package into socket with chamfered corners meeting.
- 3 Replace lid by inserting into back slot of socket body.
- 4 While pressing lid down slid forward until fully inserted into front slot of socket body.
- 5 To extract package, slide back and remove lid.

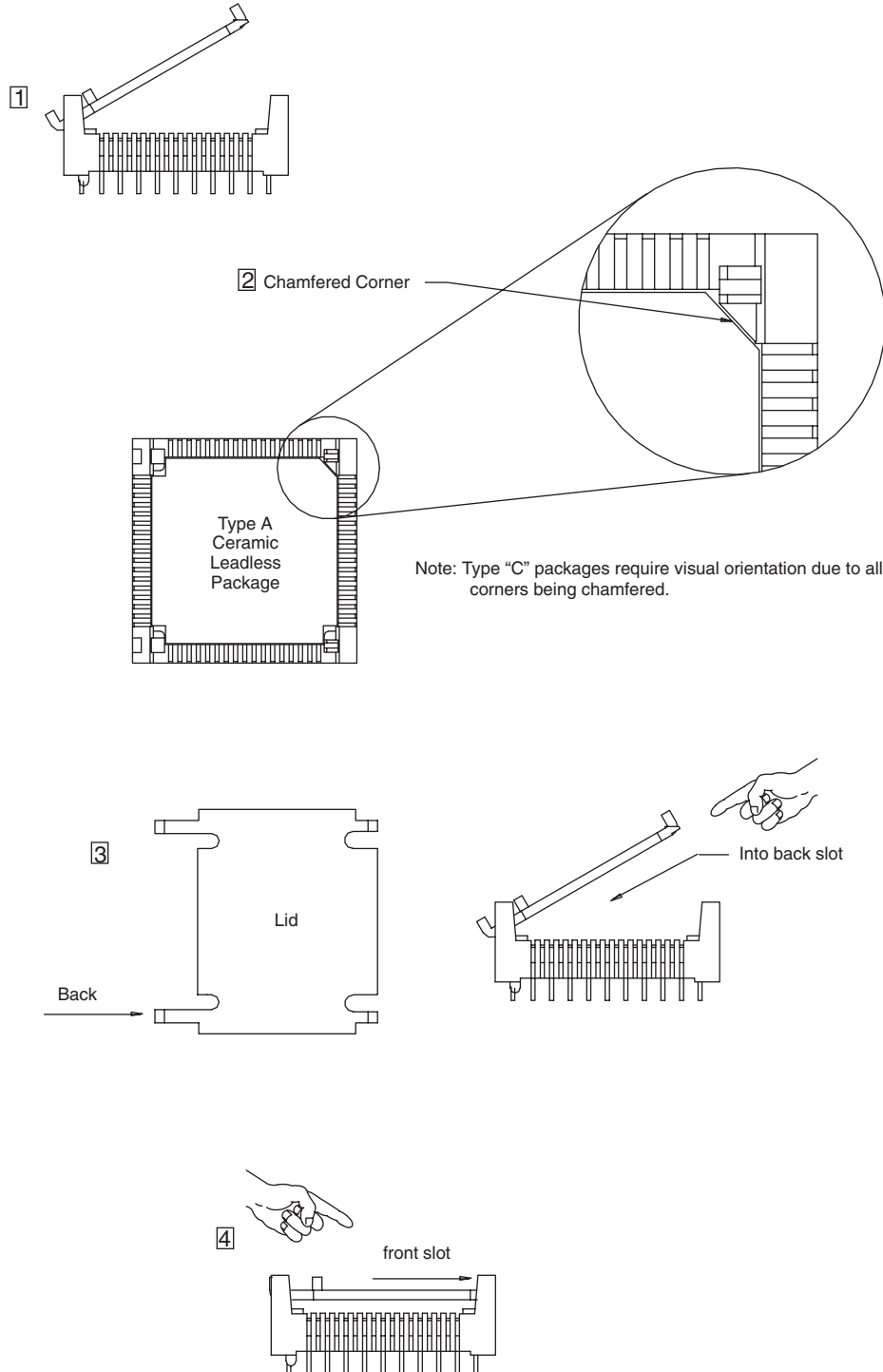

TS-0359-06  
Sheet 5 of 5

## Данный компонент на территории Российской Федерации

### Вы можете приобрести в компании MosChip.

Для оперативного оформления запроса Вам необходимо перейти по данной ссылке:

<http://moschip.ru/get-element>

Вы можете разместить у нас заказ для любого Вашего проекта, будь то серийное производство или разработка единичного прибора.

В нашем ассортименте представлены ведущие мировые производители активных и пассивных электронных компонентов.

Нашей специализацией является поставка электронной компонентной базы двойного назначения, продукции таких производителей как XILINX, Intel (ex.ALTERA), Vicor, Microchip, Texas Instruments, Analog Devices, Mini-Circuits, Amphenol, Glenair.

Сотрудничество с глобальными дистрибьюторами электронных компонентов, предоставляет возможность заказывать и получать с международных складов практически любой перечень компонентов в оптимальные для Вас сроки.

На всех этапах разработки и производства наши партнеры могут получить квалифицированную поддержку опытных инженеров.

Система менеджмента качества компании отвечает требованиям в соответствии с ГОСТ Р ИСО 9001, ГОСТ РВ 0015-002 и ЭС РД 009

### Офис по работе с юридическими лицами:

105318, г.Москва, ул.Щербаковская д.3, офис 1107, 1118, ДЦ «Щербаковский»

Телефон: +7 495 668-12-70 (многоканальный)

Факс: +7 495 668-12-70 (доб.304)

E-mail: [info@moschip.ru](mailto:info@moschip.ru)

Skype отдела продаж:

moschip.ru

moschip.ru\_4

moschip.ru\_6

moschip.ru\_9