

BAND PASS FILTER FOR AUDIO SPECTRUM ANALYZER DISPLAY

■ GENERAL DESCRIPTION

The **NJU7505A** is a band pass filter for audio spectrum analyzer display.

It consists of high and low band pass filters, CR oscillation circuit, control circuit and DC transfer circuit.

Each band pass filter using the switched capacitor filter technology operates at the shared time by 5 bands which filter constant is switched by the internal clock.

Therefore, the audio signal shared of 5 bands is output from a serial output terminal.

The 10 bands version using the double by the cascade connection is prepared.

■ PACKAGE OUTLINE

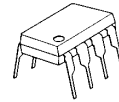

NJU7505AD

NJU7505AM

■ FEATURES

- BPF for the audio spectrum analyzer display of the 5 bands
- 10 bands extension is available by the cascade connection
- BPF using the switched capacitor filter technology
- CR oscillation circuit on chip
(External clock input is available)
- Power-on initialization circuit on chip
(External reset input is available)
- C-MOS Technology
- Package Outline

DIP8, DMP8

■ PIN CONFIGURATION

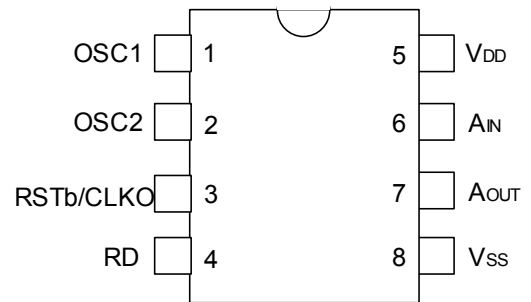

■ BLOCK DIAGRAM

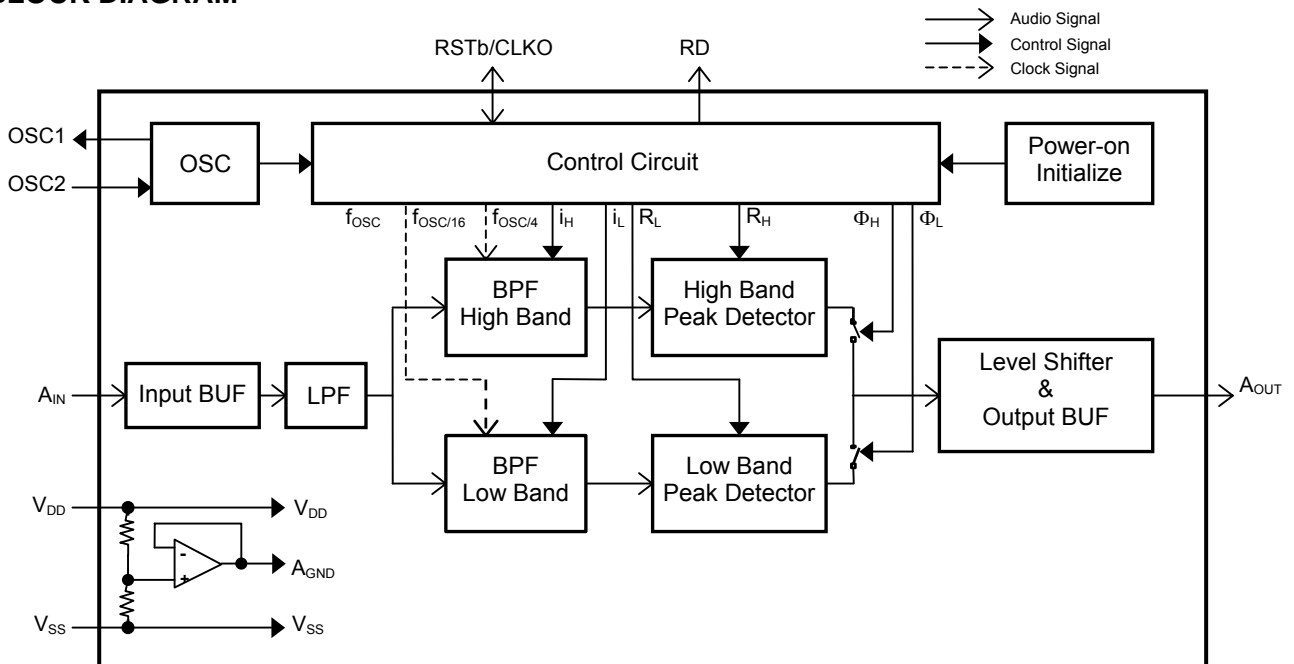

Audio Signal
 Control Signal
 Clock Signal

NJU7505A

■ TERMINAL DESCRIPTION

NO.	SYMBOL	FUNCTION
1	OSC1	External Resistor connecting terminal.
2	OSC2	External Resistor connecting terminal or External clock input terminal.
3	RSTb/CLKO	Both as Reset input terminal and the clock of $(2/3)f_{OSC}$ output terminal.
4	RD	Trigger signal for reading-out the A_{OUT} of each band output terminal.
5	V_{SS}	GND 0V
6	A_{OUT}	Peak voltage of each band output terminal.
7	A_{IN}	Audio signal input terminal.
8	V_{DD}	Positive power supply +5.0 V

■ PEAK FREQUENCY

The peak frequency in each band of **NJU7505A** are a suitable band interval which is the 5 bands at using the single and is the 10 bands at using the double by the cascade connection.

Band	Peak Frequency (Hz)	
	Using the single	Using the double
f1a	12k	12k
f1b	-	8k
f2a	3.5k	3.5k
f2b	-	2.3k
f3a	1k	1k
f3b	-	670
f4a	250	250
f4b	-	165
f5a	63	63
f5b	-	42*

Note 1) It may not be output along the expectation at the peak frequency of * marking, since the sampling time is not enough.

Note 2) The bands of f1a, f2a, ... f5a correspond to the master side and the bands of f1b, f2b, ... f5b correspond to the slave side at the cascade connection of the double.

The example of using the single

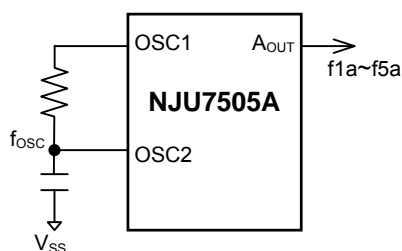

The example of using the double

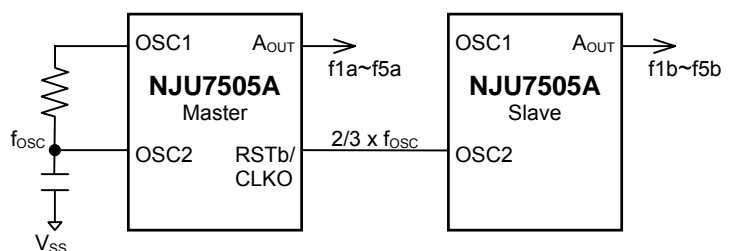

FUNCTIONAL DESCRIPTION

- Interface to external controller

The example of the interface between the **NJU7505A** and the external controller is shown below;

(1) Example of the interface to the external controller (Using the single)

After the RSTb signal from the external controller is input and then the internal circuit is initialized, each band data is output as shown below timing chart;

Since the RD signal is output before each band is switched, the external controller is to count the number of the RD signal and is to recognize the status of the band and is to read the output data from the A_{OUT} terminal through the external A/D converter.

The output type of the external controller connected to the RSTb/CLKO terminal as the RSTb input should be the N-channel and open-drain type or the diode should be connected between the RSTb/CLKO terminal and the output terminal of the external controller, so that the voltage of the RSTb/CLKO terminal is not gotten over the V_{SS} level.

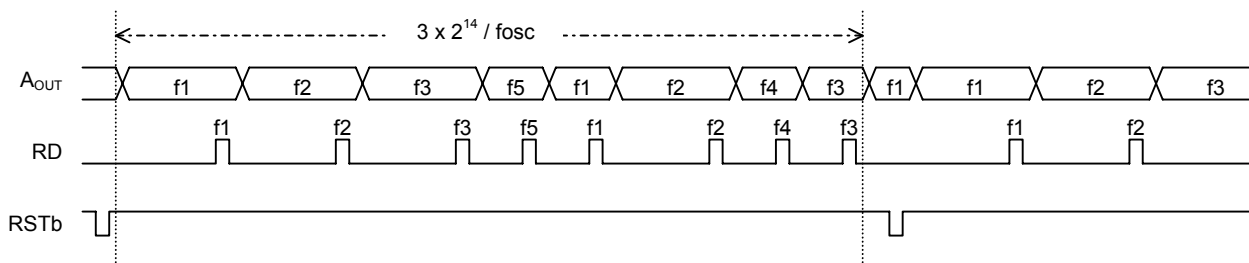
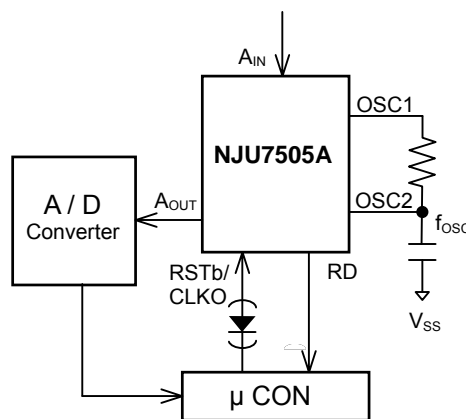

Since the RD signal is output before $248/f_{OSC}$ of each band switched, the output data should be read out within the limited time as shown right;

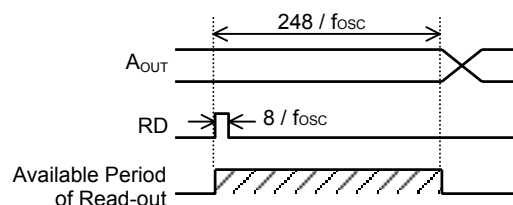

If the RSTb signal which pulse width is more than $4/f_{OSC}$ is input, the internal circuit is initialized and the data of f1 band is output from the A_{OUT} terminal after $52/f_{OSC}$ of the rise edge of the RSTb signal.

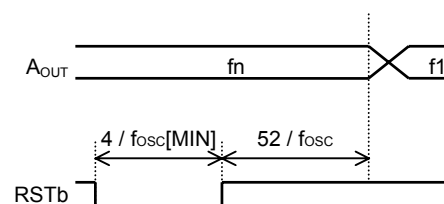

NJU7505A

(2) Example of the interface to the external controller (Using the double)

The 10 bands application is available using the cascade connection of the double **NJU7505A** as shown below.

After the RSTb signals from the external controller are input to each of the master and the slave of the **NJU7505A** and then each internal circuit is initialized, each band data is output as shown below timing chart;

Since the RD signals are output from the master and the slave before each band is switched, the external controller is to count the number of the RD signals and is to recognize the status of the band and is to read the output data from each A_{OUT} terminals through the external A/D converter.

The master clock for the slave is provided with the output signal from the RSTb/CLKO terminal of the master. The master clock for the slave is stopped when the RSTb signal is input from the external controller to the master, so that the RSTb/CLKO terminal of the master is used both as the RSTb input of the master and the master clock for the slave.

The output type of the external controller connected to each RSTb/CLKO terminal as the RSTb input should be the N-channel and open-drain type or the diode's should be connected between each RSTb/CLKO terminal and the output terminals of the external controller, so that the voltage of each RSTb/CLKO terminal is not gotten over the V_{SS} level.

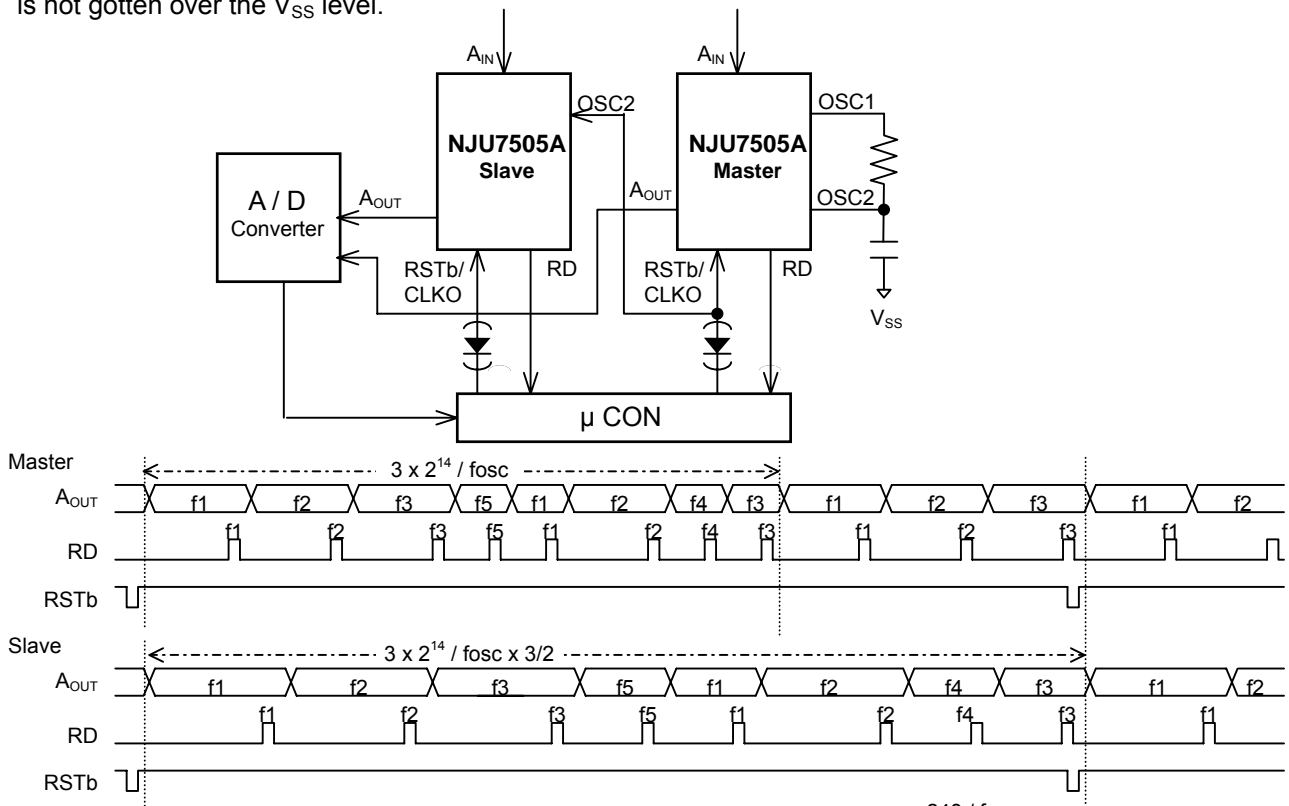

Since each RD signal of the master and the slave is output before $248/f_{OSC}$ ($248/f_{OSC} \times 3/2$) of each band switched, the output data should be read out within the limited time as shown right;

* The "()" is corresponded to the slave.

If the RSTb signal which pulse width is more than $4/f_{OSC}$ is input to the master, the internal circuit is initialized and the data of f1 band is output from the A_{OUT} terminal of the master after $52/f_{OSC}$ of the rise edge of the RSTb signal.

The RSTb signal for the slave should be set to "L" level while the RSTb signal for the master is "L" level and should keep "L" level more than $6/f_{OSC}$. So the slave operates as same as the master after $78/f_{OSC}$ of the rise edge of the RSTb signal for the slave.

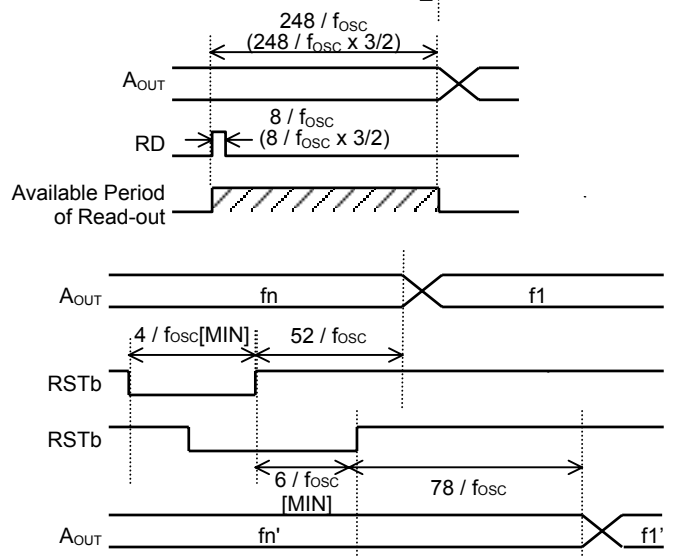

■ ABSOLUTE MAXIMUM RATINGS

(Ta=25°C)

PARAMETER	SYMBOL	RATINGS	UNIT	NOTE
Supply Voltage	V _{DD}	-0.3 to +7	V	
Input Voltage	V _{IN}	-0.3 to V _{DD} +0.3	V	7
	V _{IO}	-0.3 to 0		5, 8
Output Voltage	V _{OUT}	-0.3 to V _{DD} +0.3	V	
Power Dissipation	P _D	500(DIP), 300(DMP)	mW	
Operating Temperature	T _{opr}	-30 to 85	°C	
Storage Temperature	T _{stg}	-55 to 125	°C	

Note 3) If the IC are used on condition above the absolute maximum ratings, the IC may be destroyed. Using the IC within electric characteristic conditions will cause malfunction and poor reliability.

Note 4) All voltage values are specified as V_{SS} = 0V.

Note 5) When the voltage of the RSTb/CLKO terminal is gotten over the V_{SS} level, the diode should be connected between the RSTb/CLKO terminal and the external.

Note 6) Decoupling capacitor should be connected between the V_{DD} terminal and the V_{SS} due to the stabilization of the operation.

Note 7) Applied to the A_{IN} or the OSC2 terminals.

Note 8) Applied to the RSTb/CLKO terminal.

■ DC CHARACTERISTICS

(V_{DD}=5V, V_{SS}= 0V, Ta=25°C)

PARAMETER	SYMBOL	CONDITITONS		MIN	TYP	MAX	UNIT	NOTE
Operating Voltage	V _{DD}			4.5	5.0	6.0	V	
Operating Current	I _{DD}	V _{DD} Terminal		-	6.0	12.0	mA	
Input Leak Current 1	I _{IL1}	A _{IN} Terminal	V _{IL1} =0V	-0.1	-0.05	-0.033	mA	
	I _{IH1}		V _{IH1} =5V	0.033	0.05	0.1		
Input Leak Current 2	I _{IL2}	RSTb/CLKO Terminal	V _{IH2} =0V	-0.2	-0.1	-0.05	mA	
External Clock Input Voltage	V _{ILC}	OSC2 Terminal		0	-	1.5	V	
	V _{IHC}			3.5	-	5.0		
Output Voltage 1	V _{OL1}	RD Terminal	I _{OL1} =100μA	0	-	0.5	V	
	V _{OH1}		I _{OH1} =-100μA	4.5	-	5.0		
Output Voltage 2	V _{OL2}	RSTb/CLKO Terminal	I _{OL1} =100μA	0	-	0.5	V	
	V _{OH2}		I _{OH1} =-5μA	4.25	4.5	4.75		
Output Offset Voltage	V _{OS}	A _{OUT} Terminal	A _{IN} :OPEN	-	-	300	mV	
BPF Output Voltage	V _{OUT}	A _{OUT} Terminal Sine Wave Input		-	26.0	-	dB	9,10,11
		f _{IN} =f1 to f5	V _{IN} =200mV _p	3.5	-	-		

Note 9) This specification is tested on condition of f_{CLK}=400kHz (The external clock is input to the OSC2 terminal through the capacitor for AC coupling).

Note 10) Each input frequency of f1 to f5 is referred to the table of the " PEAK FREQUENCY ".

Note 11) This specification is calculated from " V_{OUT} / V_{IN} ".

■ AC CHARACTERISTICS

($V_{DD}=4.5 \sim 6.0V$, $V_{SS}=0V$, $T_a=25^\circ C$)

PARAMETER	SYMBOL	CONDITIONS	MIN	TYP	MAX	UNIT	NOTE
Oscillation Clock Freq	f_{OSC}	RSTb/CLKO Terminal $V_{DD}=5V$	360	400	440	kHz	12
External Clock Frequency	f_{CLK}	RSTb/CLKO Terminal $V_{ILC}=0V$ $V_{IHC}=V_{DD}$		400	800	kHz	13
RD Pulse Width	t_{PWRD}	RD Terminal	Master		$8/f_{OSC}$ $8/f_{CLK}$	μs	14
			Slave		$12/f_{OSC}$ $12/f_{CLK}$		
RSTb Pulse Width	t_{PWRS}	RSTb/CLKO Terminal	Master	$4/f_{OSC}$ $4/f_{CLK}$		μs	15
			Slave	$6/f_{OSC}$ $6/f_{CLK}$			
RSTb Rise/Fall Time	t_r, t_f	RSTb/CLKO Terminal			100	μs	15

Note 12) The example for the CR Oscillation

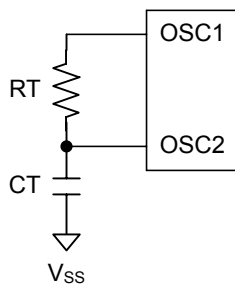

RT: $13k\Omega(\pm 2\%)$
CT: $220pF(\pm 5\%)$

*The oscillation clock frequency is calculated from the output frequency of the RSTb/CLKO terminal by 3/2.

Note 13) The example for the external clock input

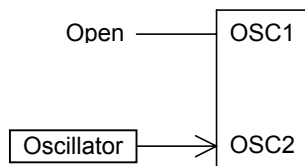

The input signal for the OSC2 terminal should be the condition of the pulse of DUTY $50\% \pm 10\%$.

* The oscillation clock frequency is calculated from the output frequency of the RSTb/CLKO terminal by 3/2.

Note 14) The output wave form of the RD terminal.

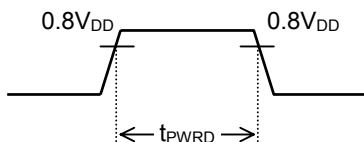

Note 15) The input wave form of the RSTb terminal.

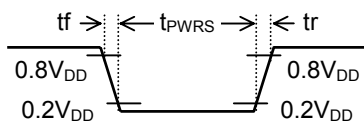

■ APPLICATION CIRCUIT (1)

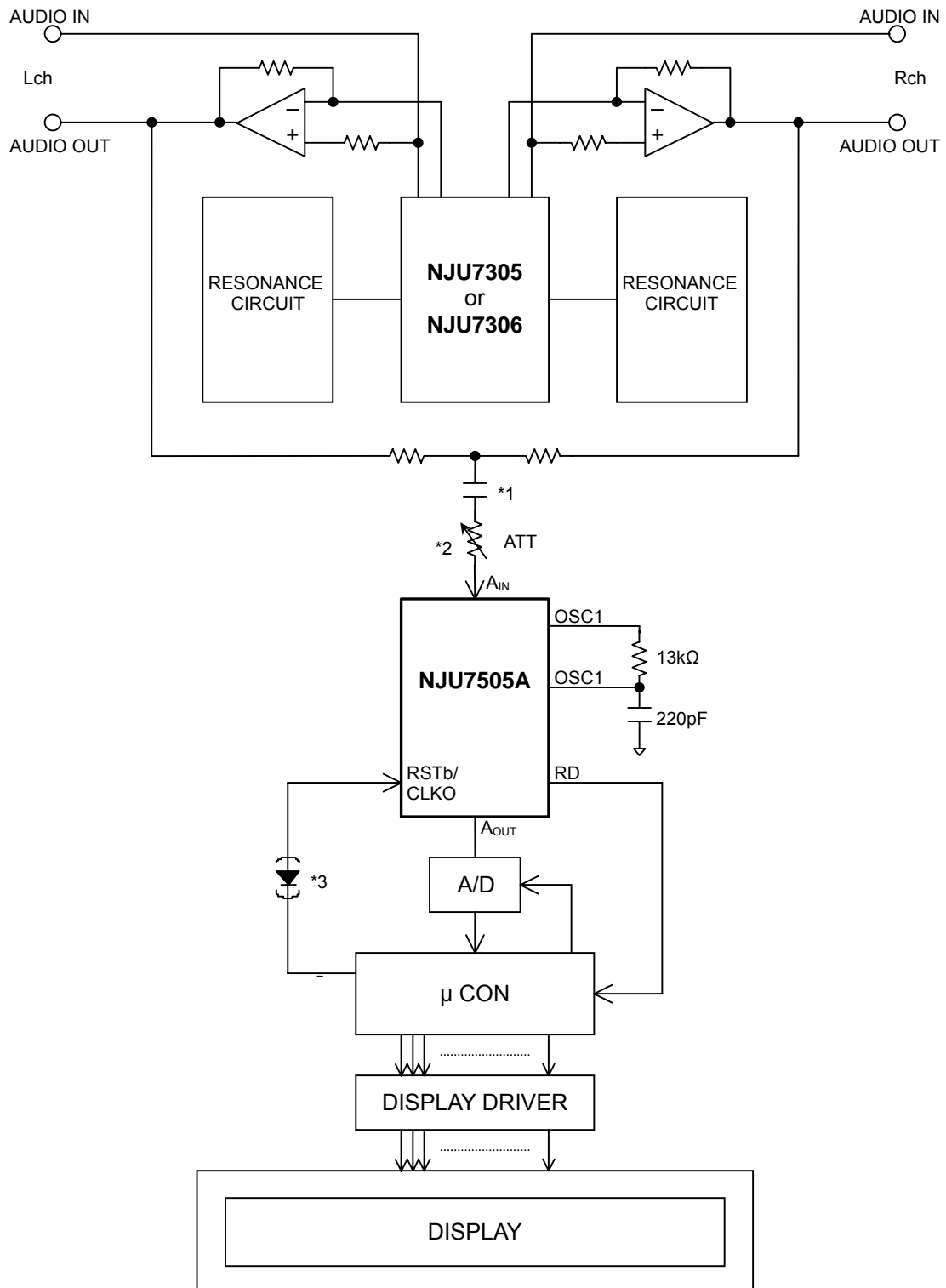

*1) The capacitor for AC coupling connected to the AIN terminal should be needed.

*2) Connecting the attenuator, the dynamic range of the display can be changed.

*3) When the voltage of the output terminal of the μCON gets over the VSS level, the diode should be connected between the RSTb/CLKO terminal and the output of the μCON.

NJU7505A

APPLICATION CIRCUIT (2)

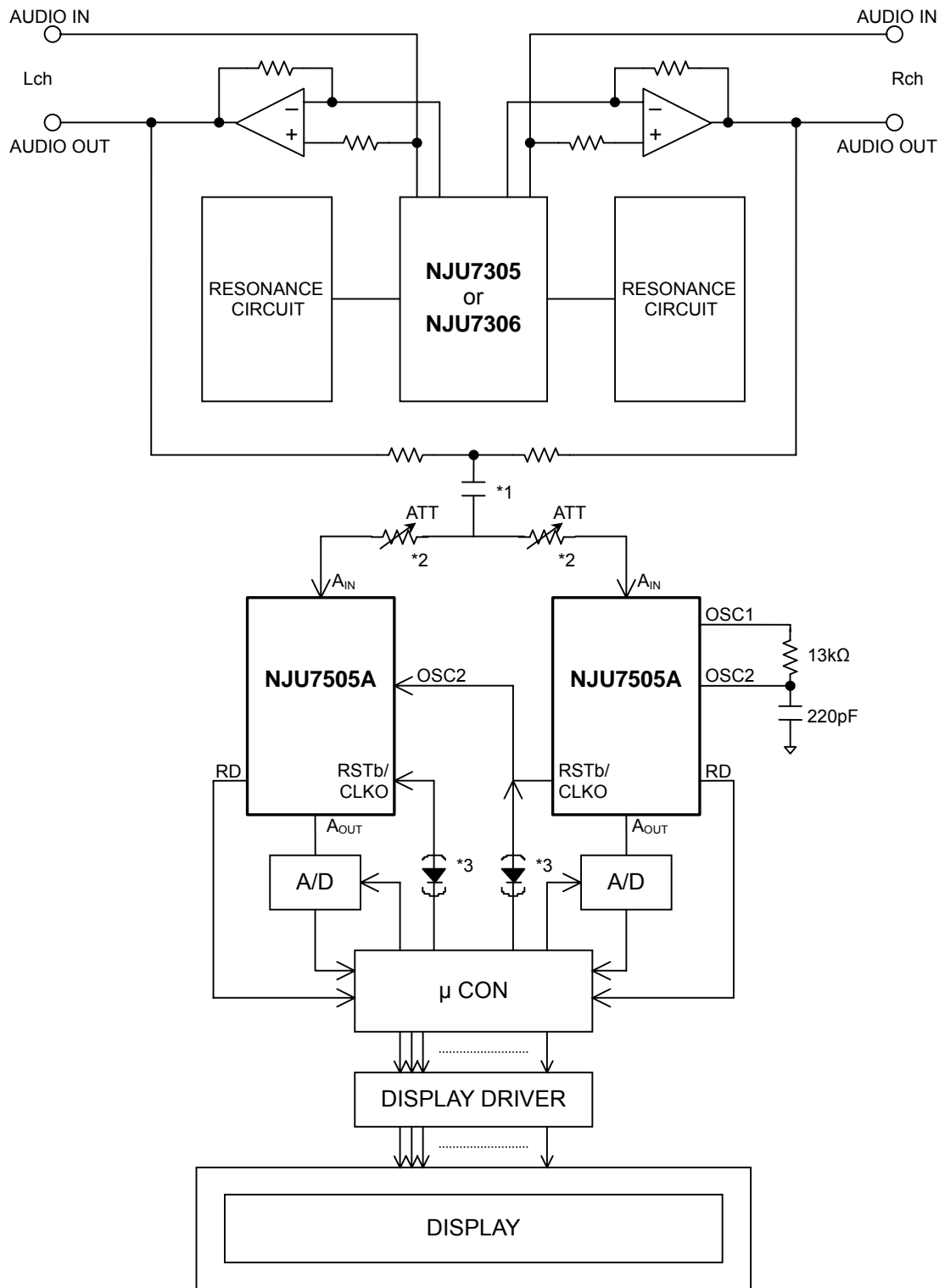

- *1) The capacitor for AC coupling connected to the A_{IN} terminal should be needed.
- *2) Connecting the attenuator, the dynamic range of the display can be changed.
- *3) When the voltage of the output terminal of the μ CON gets over the VSS level, the diode should be connected between the RSTb/CLKO terminal and the output of the μ CON.

[CAUTION]
 The specifications on this databook are only given for information, without any guarantee as regards either mistakes or omissions. The application circuits in this databook are described only to show representative usages of the product and not intended for the guarantee or permission of any right including the industrial rights.

Mouser Electronics

Authorized Distributor

Click to View Pricing, Inventory, Delivery & Lifecycle Information:

[NJR:](#)

[NJU7505AM](#)

Данный компонент на территории Российской Федерации

Вы можете приобрести в компании MosChip.

Для оперативного оформления запроса Вам необходимо перейти по данной ссылке:

<http://moschip.ru/get-element>

Вы можете разместить у нас заказ для любого Вашего проекта, будь то серийное производство или разработка единичного прибора.

В нашем ассортименте представлены ведущие мировые производители активных и пассивных электронных компонентов.

Нашей специализацией является поставка электронной компонентной базы двойного назначения, продукции таких производителей как XILINX, Intel (ex.ALTERA), Vicor, Microchip, Texas Instruments, Analog Devices, Mini-Circuits, Amphenol, Glenair.

Сотрудничество с глобальными дистрибьюторами электронных компонентов, предоставляет возможность заказывать и получать с международных складов практически любой перечень компонентов в оптимальные для Вас сроки.

На всех этапах разработки и производства наши партнеры могут получить квалифицированную поддержку опытных инженеров.

Система менеджмента качества компании отвечает требованиям в соответствии с ГОСТ Р ИСО 9001, ГОСТ РВ 0015-002 и ЭС РД 009

Офис по работе с юридическими лицами:

105318, г.Москва, ул.Щербаковская д.3, офис 1107, 1118, ДЦ «Щербаковский»

Телефон: +7 495 668-12-70 (многоканальный)

Факс: +7 495 668-12-70 (доб.304)

E-mail: info@moschip.ru

Skype отдела продаж:

moschip.ru

moschip.ru_4

moschip.ru_6

moschip.ru_9