

**TECHNICAL:**  
**RATED VOLTAGE:** 120VAC, 208VAC, 240VAC, 277VAC, 120/240VAC, 120/208VAC Dual Voltage, 120/208VAC 3Ø, 208VAC 3Ø, 240VAC 3Ø (277VAC non-U.L.)  
**OPERATING VOLTAGE RANGE:** 85% TO 110% OF RATED  
**CURRENT:** UP TO 30 AMPS OR WIRING DEVICE RATING  
**FREQUENCY:** 60Hz, 50Hz (AVAILABLE non-UL)  
**TRIP LEVEL:** 5 ± 1mA  
**PHASE:** SINGLE, DUAL VOLTAGE, AND THREE-PHASE  
**RESPONSE TIME:** 25 mS MAX. @500 OHM FAULT  
**DIELECTRIC WITHSTAND:** 1500 VRMS ACROSS CONTACT  
 4000 VRMS BETWEEN CONDUCTORS AND ENCLOSURE  
 6000V IMPULSE, 0.5 MICROSECOND RISE TIME 100KHZ RINGING FREQUENCY WITH 40% DECAY PER CYCLE  
**OPERATING TEMPERATURE RANGE:** -35°C TO +66°C (-31°F TO +151°F)  
**LEAKAGE CURRENT @ 93% HUMIDITY:** ZERO  
**OVERLOAD CURRENT:** 180 AMPS, 50% INDUCTIVE (25 CYCLES)  
**RF NOISE SUSCEPTIBILITY:** NORMAL OPERATION WITH 0.5 VRMS INJECTED ON POWER LINE WITH FREQUENCIES UP TO 450 MHz  
**CURRENT FILTERS:** SPECIFICALLY FILTERED TO MINIMIZE NUISANCE TRIPS IN WELDING, VARIABLE FREQUENCY DRIVE AND OTHER 'ELECTRICALLY NOISY' APPLICATIONS  
**LET GO LINE VOLTAGE:** 60% OF RATED  
**GROUNDING NEUTRAL DETECTION:** 2 OHMS OR LESS (ON APPLICABLE MODELS ONLY)

**GENERAL:**  
**CONSTRUCTION:** INDUSTRIAL GRADE DESIGN  
**TYPE:** CLASS A  
**POWER-UP TYPE:** AUTO OR MANUAL  
**ENDURANCE:** 5000 OPERATIONS MINIMUM AT RATED LOAD  
**OPEN NEUTRAL PROTECTION:** TRIPS UPON LOSS OF NEUTRAL (ON APPLICABLE MODELS ONLY)  
**GROUNDING NEUTRAL PROTECTION:** TRIPS IF GROUND AND NEUTRAL TOUCH AT LOAD SIDE (ON APPLICABLE MODELS ONLY)  
**POWER ON INDICATION:** LIGHTED GREEN LED  
**POWER OFF INDICATION:** BLINKING RED LED, PLUS OPTIONAL ANNUNCIATOR OF AC/DC OUTPUTS (ON APPLICABLE MODELS ONLY)  
**ENCLOSURE:** NEMA 4X/P6  
**MOUNTING TYPE:** PANEL, SURFACE AND PORTABLE  
**WIRING APPLICATION:** 3,4,5 WIRE SINGLE, SPLIT, AND 3-PHASE  
**WIRING CONNECTIONS:** PORTABLE (IN-LINE) AND PERMANENT (FIXED MOUNT) (SEE WIRING INSTRUCTIONS)  
**SWITCH INTERFACE:** DOUBLE INSULATED  
**LATCHING MECHANISM:** ELECTROMAGNETIC  
**FALSE TRIP DUE TO IMPACT:** NONE  
**AGENCY APPROVAL:** cULus, CSA, CSAus and cCSAus (U.L.943 and CSA C22.2 No. 144) (277VAC non-U.L.)

**INDUSTRIAL GRADE DESIGN**  
 CLASS A  
 AUTO OR MANUAL  
 5000 OPERATIONS MINIMUM AT RATED LOAD  
 TRIPS UPON LOSS OF NEUTRAL (ON APPLICABLE MODELS ONLY)  
 TRIPS IF GROUND AND NEUTRAL TOUCH AT LOAD SIDE (ON APPLICABLE MODELS ONLY)  
 LIGHTED GREEN LED  
 BLINKING RED LED, PLUS OPTIONAL ANNUNCIATOR OF AC/DC OUTPUTS (ON APPLICABLE MODELS ONLY)  
 NEMA 4X/P6  
 PANEL, SURFACE AND PORTABLE  
 3,4,5 WIRE SINGLE, SPLIT, AND 3-PHASE  
 PORTABLE (IN-LINE) AND PERMANENT (FIXED MOUNT) (SEE WIRING INSTRUCTIONS)  
 DOUBLE INSULATED  
 ELECTROMAGNETIC  
 NONE  
 cULus, CSA, CSAus and cCSAus (U.L.943 and CSA C22.2 No. 144) (277VAC non-U.L.)

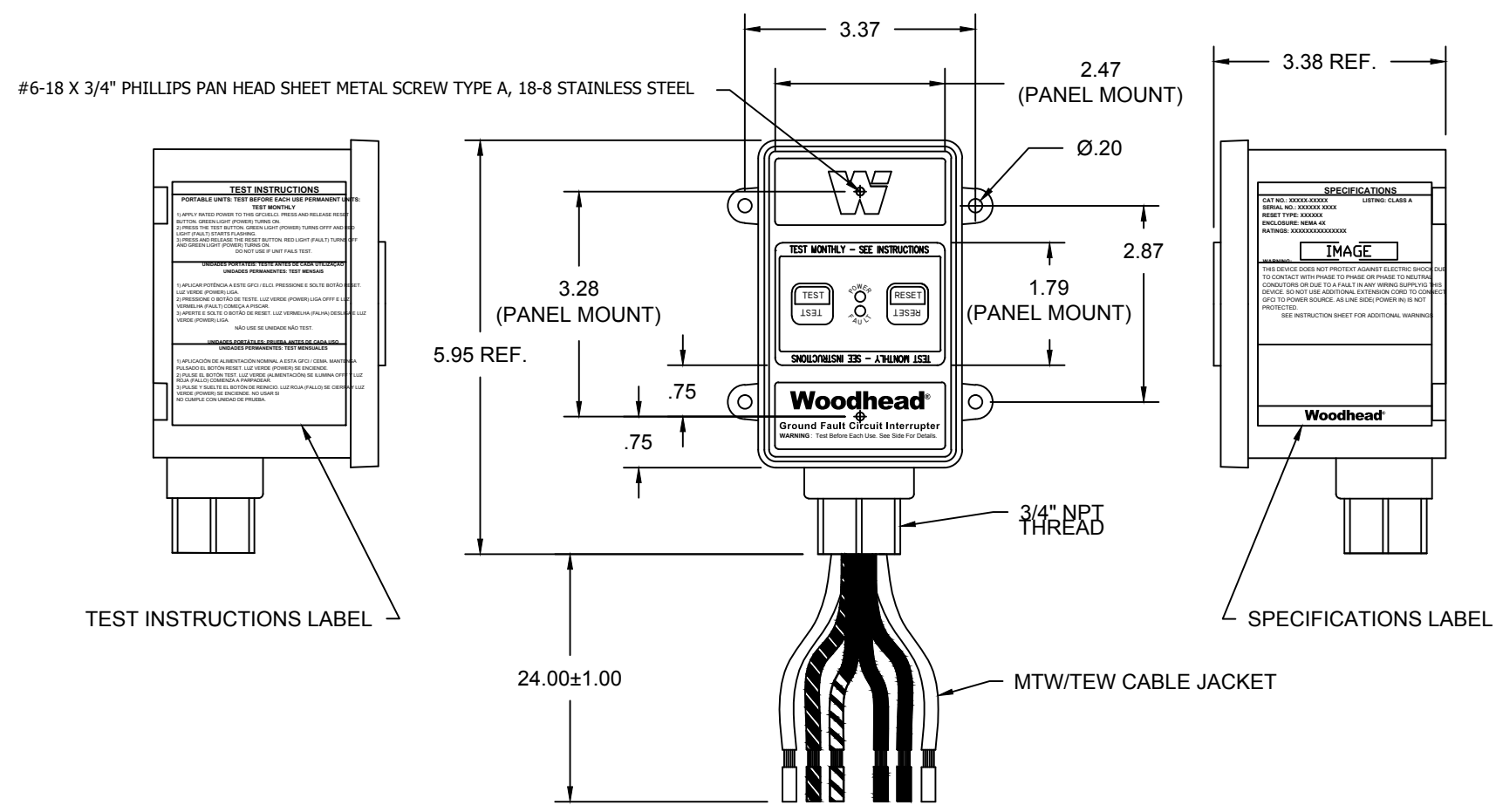

**FIGURE 1**

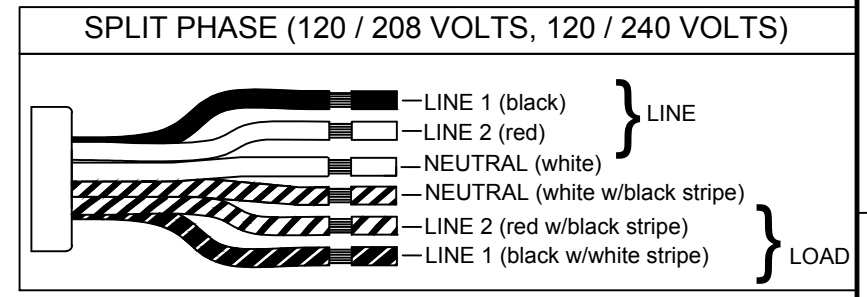

**FIGURE 2**

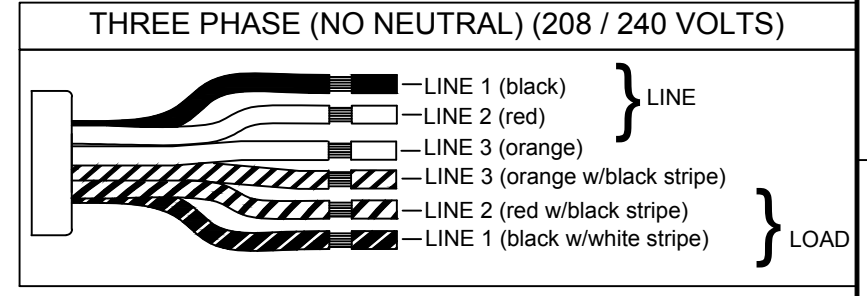

**FIGURE 3**

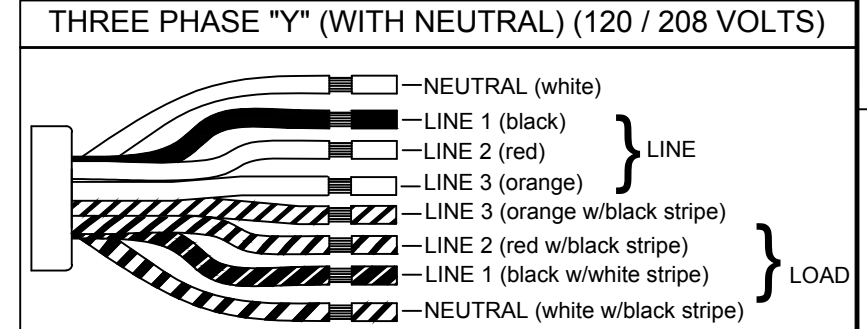

RESET TYPE	MATERIAL NO.	ENGINEERING NO.	PHASE	FIGURE
MANUAL	1301530239	30053-2M6F	SPLIT PHASE	FIGURE 1
	1301530240	30053-2M3F	THREE PHASE	FIGURE 2
	1301530241	30053-2M2F	THREE PHASE	FIGURE 2
AUTOMATIC	1301530242	30053-2M5F	THREE PHASE W/ NEUTRAL	FIGURE 3
	1301530243	30053-2A6F	SPLIT PHASE	FIGURE 1
	1301530244	30053-2A3F	THREE PHASE	FIGURE 2
	1301530245	30053-2A2F	THREE PHASE	FIGURE 2
	1301530246	30053-2A5F	THREE PHASE W/ NEUTRAL	FIGURE 3

UPDATED SPECS EC NO: IPG2014-1788 DRWN: BARDEN 2014/04/14 CHKD: HKNEELAN 2014/04/30 APPR: JFMURPHY 2014/03/27	QUALITY SYMBOLS ▽=0 ◁=0	GENERAL TOLERANCES (UNLESS SPECIFIED)		DIMENSION STYLE IN/MM		SCALE NTS	DESIGN UNITS INCH	THIRD ANGLE PROJECTION	
		4 PLACES	±---	±---	DRAWN BY				DATE
		3 PLACES	±---	±.005	BARDEN	2014/01/08			
		2 PLACES	±0.13	±.010	CHECKED BY	DATE			
1 PLACE	±0.25	±.020	HKNEELAN	2014/03/07					
ANGULAR ±1/2°		DRAFT WHERE APPLICABLE MUST REMAIN WITHIN DIMENSIONS		APPROVED BY JFMURPHY		DATE 2014/03/27		MOLEX INCORPORATED	
MATERIAL NO. SEE CHART		DOCUMENT NO. SD-130153-039		SHEET NO. 1 OF 1					
SIZE B		THIS DRAWING CONTAINS INFORMATION THAT IS PROPRIETARY TO MOLEX INCORPORATED AND SHOULD NOT BE USED WITHOUT WRITTEN PERMISSION							

## Данный компонент на территории Российской Федерации

### Вы можете приобрести в компании MosChip.

Для оперативного оформления запроса Вам необходимо перейти по данной ссылке:

<http://moschip.ru/get-element>

Вы можете разместить у нас заказ для любого Вашего проекта, будь то серийное производство или разработка единичного прибора.

В нашем ассортименте представлены ведущие мировые производители активных и пассивных электронных компонентов.

Нашей специализацией является поставка электронной компонентной базы двойного назначения, продукции таких производителей как XILINX, Intel (ex.ALTERA), Vicor, Microchip, Texas Instruments, Analog Devices, Mini-Circuits, Amphenol, Glenair.

Сотрудничество с глобальными дистрибьюторами электронных компонентов, предоставляет возможность заказывать и получать с международных складов практически любой перечень компонентов в оптимальные для Вас сроки.

На всех этапах разработки и производства наши партнеры могут получить квалифицированную поддержку опытных инженеров.

Система менеджмента качества компании отвечает требованиям в соответствии с ГОСТ Р ИСО 9001, ГОСТ РВ 0015-002 и ЭС РД 009

### Офис по работе с юридическими лицами:

105318, г.Москва, ул.Щербаковская д.3, офис 1107, 1118, ДЦ «Щербаковский»

Телефон: +7 495 668-12-70 (многоканальный)

Факс: +7 495 668-12-70 (доб.304)

E-mail: [info@moschip.ru](mailto:info@moschip.ru)

Skype отдела продаж:

moschip.ru

moschip.ru\_4

moschip.ru\_6

moschip.ru\_9