



Metal Oxide Varistor

Disc type

SIOV-Q14K680

Ordering code: B72214Q0681K101

Data sheet

Form: FBLE3K/b

File name: Q14K680_a

MODIFICATIONS: New data sheet

REMARKS:

Prepared by	Hotwagner	Release	signed: PE / Hotwagner		signed: QS / Zödl		
			signed:		signed:		
ISSUE DATE	22.05.02	ISSUE	a	PUBLISHER	KH PE VAR	PAGE	0/6

SIOV nomenclature

Q	=	EnergetiQ™ Series
14	=	Rated disk diameter
K	=	Tolerance of V_V at 1mA : $\pm 10\%$
680	=	Max. AC voltage

Figure: Dimensions given in Millimeters (mm)

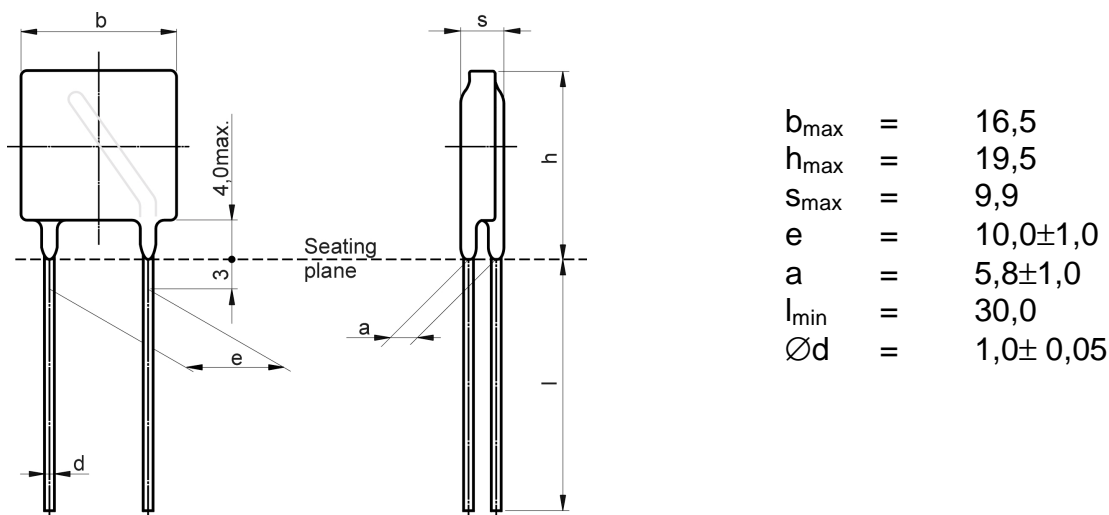

Electrical data:

Maximum Ratings (85°C):

Max. operating AC voltage	V_{RMS}	=	680V
Max. operating DC voltage	V_{DC}	=	895V
Surge current (8/20 μ s) 1 time	I_{max}	=	6000A
Energy absorption (2ms) 1 time	W_{max}	=	320J
Average power dissipation	P_{max}	=	0,80W

Characteristics (25°C):

Varistor voltage at 1mA	V_V	=	$1100V \pm 10\%$
Clamping voltage at 65A (8/20 μ s)	$V_{C,max}$	=	1815V
Typ. capacitance at 1 kHz	C	=	200pF

ISSUE DATE	22.05.02	ISSUE	a	PUBLISHER	KH PE VAR	PAGE	1/6
------------	----------	-------	---	-----------	-----------	------	-----

V/I Characteristic:

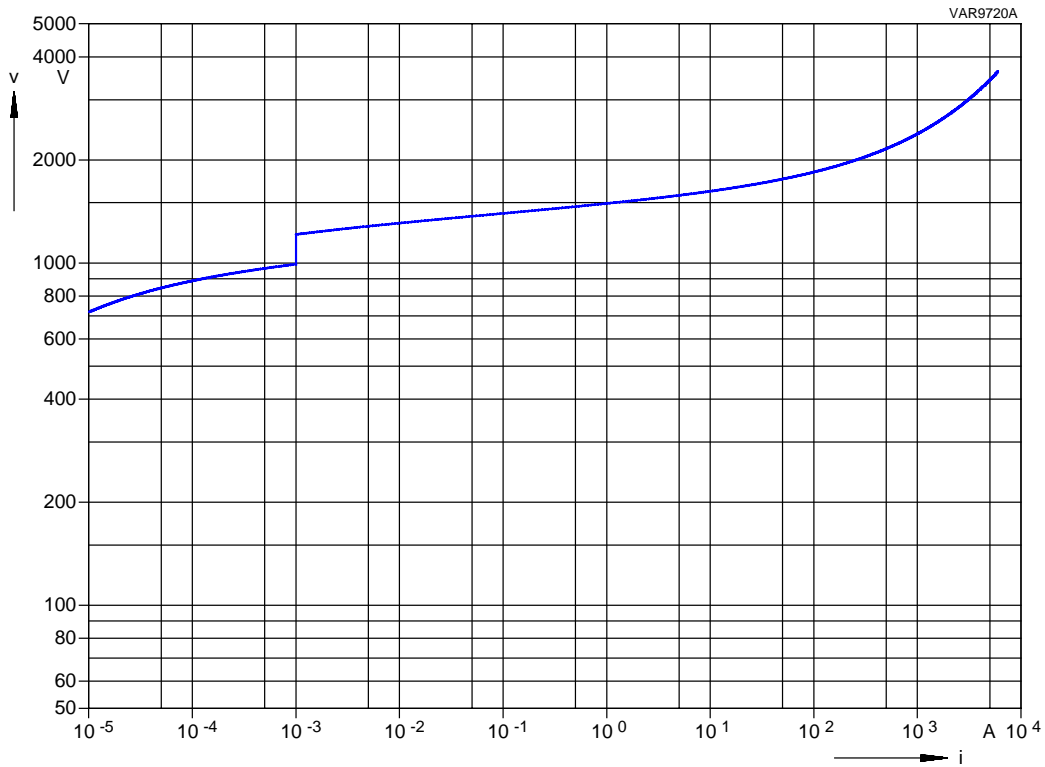

Derating:

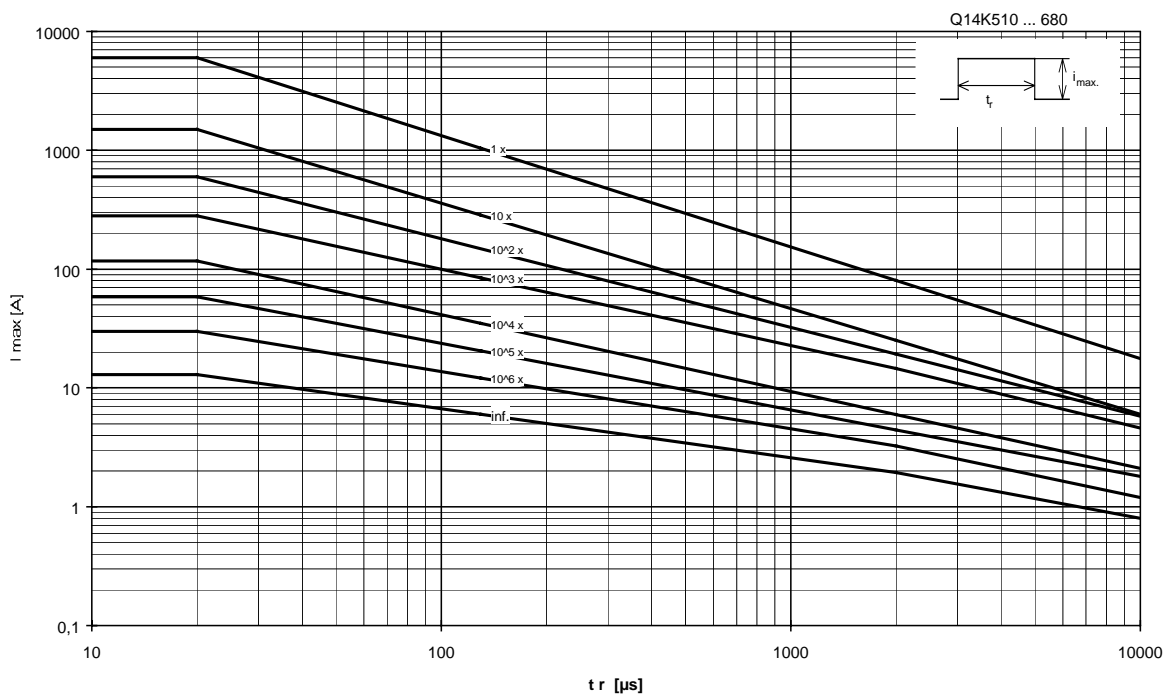

Reliability Data:

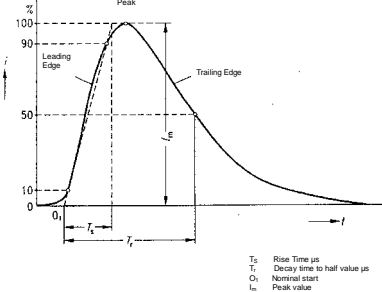
	Characteristics	Test Methods/Description	Specifications
E	Varistor Voltage	The voltage between two terminals with the specified measuring current applied is called V_V (1 mA _{DC} @ 0.2 - 2 s).	To meet the specified value.
L E C T R I C A L	Clamping Voltage	<p>The maximum voltage between two terminals with the specified standard impulse current (8/20µs) illustrated below applied.</p> 	To meet the specified value.
C	Surge current derating, 8/20 µs	100 surge currents (8/20 µs), unipolar, interval 30 s, amplitude corresponding to derating curve for 20 µs	$ \Delta V/V (1 \text{ mA}) \leq 10 \%$ (measured in direction of surge current) No visible damage
L	Surge current derating, 2 ms	100 surge currents (2ms), unipolar, interval 120s, amplitude corresponding to derating curve for 2ms	$ \Delta V/V (1 \text{ mA}) \leq 10 \%$ (measured in direction of surge current) No visible damage



Data sheet

	Characteristics	Test Methods/Description	Specifications							
M	Tensile strength	After gradually applying the force specified below and keeping the unit fixed for 10 seconds, the terminal shall be visually examined for any damage.	$ \Delta V/V (1 \text{ mA}) \leq 5 \%$ No break of solder joint, no wire break							
		<table border="1"> <thead> <tr> <th>Terminal diameter</th> <th>Force</th> </tr> </thead> <tbody> <tr> <td>0.5 mm</td> <td>5 N</td> </tr> <tr> <td>0.6 mm</td> <td>10 N</td> </tr> <tr> <td>0.8 mm</td> <td>10 N</td> </tr> <tr> <td>1.0 mm</td> <td>20 N</td> </tr> </tbody> </table>		Terminal diameter	Force	0.5 mm	5 N	0.6 mm	10 N	0.8 mm
Terminal diameter	Force									
0.5 mm	5 N									
0.6 mm	10 N									
0.8 mm	10 N									
1.0 mm	20 N									
E C H	Vibration	After repeatedly applying a single harmonic vibration according to the table below. Thereafter, the unit shall be visually examined. frequency range: 10 ... 55 Hz amplitude: 0.75 mm or 98 m/s ² duration: 6 h (3 x 2 h) pulse: sine wave	$ \Delta V/V (1 \text{ mA}) \leq 5 \%$ No visible damage							
A N I C A L	Solderability	After dipping the terminals to a depth of approximately 3 mm from the body in a soldering bath of 235°C for 5 seconds, the terminals shall be visually examined.	The inspection shall be carried out under adequate light with normal eyesight or with the assistance of a magnifier capable of giving a magnification of 4 times to 10 times. The dipped surface shall be covered with a smooth and bright solder coating with no more than small amounts of scattered imperfections such as pinholes or un-wetted or de-wetted areas. These imperfections shall not be concentrated in one area.							



Data sheet

	Characteristics	Test Methods/Description	Specifications
M E C H A N I C A L	Resistance to soldering heat	Each lead shall be dipped into a solder bath having a temperature of $260 \pm 5^{\circ}\text{C}$ to a point 2.0 to 2.5 mm from the body of the unit, be held there for 10 ± 1 s and then be stored at room temperature and normal humidity for 1 to 2 hours. The change of V_v and mechanical damages shall be examined.	$ \Delta V/V (1 \text{ mA}) \leq 5 \%$ No visible damage
	Electric strength	2500 V_{RMS} , 10 s The varistor is placed in a container holding 1.6 \pm 0.2 mm diameter metal balls such that only the terminations of the varistor are protruding. The specified voltage shall be applied between both terminals of the specimen connected together and the electrode inserted between the metal balls.	No breakdown

ISSUE DATE	22.05.02	ISSUE	a	PUBLISHER	KH PE VAR	PAGE	5/6
------------	----------	-------	---	-----------	-----------	------	-----

Data sheet

	Characteristics	Test Methods/Description	Specifications												
E N V I	Max. AC operating voltage	After being continuously applied the maximum allowable voltage at $85 \pm 2^\circ\text{C}$ for 1000 hours, the specimen shall be stored at room temperature and normal humidity for 1 to 2 hours. Thereafter, the change of V_v shall be measured.	$ \Delta V/V (1 \text{ mA}) \leq 10 \%$												
	Damp heat, steady state	The specimen shall be subjected to $40 \pm 2^\circ\text{C}$, 90 to 95 % r.H. for 56 days without load and then stored at room temperature and normal humidity for 1 to 2 hours. Thereafter, the change of V_v shall be measured.	$ \Delta V/V (1 \text{ mA}) \leq 10 \%$												
R O N M	Climatic sequence	The specimen shall be subjected to: a) dry heat at $+85^\circ\text{C}$, 16 h b) damp heat, 1st cycle: 55°C , 93 % r.H., 24 h c) cold, -40°C , 2 h d) damp heat, additional 5 cycles: 55°C , 93 % r.H., 24 h/cycle Then the specimen shall be stored at room temperature and normal humidity for 1 to 2 hours. Thereafter, the change of V_v shall be measured.	$ \Delta V/V (1 \text{ mA}) \leq 10 \%$												
E N T A L	Fast temperature cycling	The temperature cycle shown below shall be repeated 5 times. Then the specimen shall be stored at room temperature and normal humidity for 1 to 2 hours. The change of V_v and mechanical damage shall be examined. <table border="1" style="margin-left: auto; margin-right: auto;"> <thead> <tr> <th>Step</th> <th>Temperature ($^\circ\text{C}$)</th> <th>Period (min.)</th> </tr> </thead> <tbody> <tr> <td>1</td> <td>-40 ± 3</td> <td>30 ± 3</td> </tr> <tr> <td>2</td> <td>transition time</td> <td>< 10 s</td> </tr> <tr> <td>3</td> <td>85 ± 2</td> <td>30 ± 3</td> </tr> </tbody> </table>	Step	Temperature ($^\circ\text{C}$)	Period (min.)	1	-40 ± 3	30 ± 3	2	transition time	< 10 s	3	85 ± 2	30 ± 3	$ \Delta V/V (1 \text{ mA}) \leq 5 \%$ No visible damage
Step	Temperature ($^\circ\text{C}$)	Period (min.)													
1	-40 ± 3	30 ± 3													
2	transition time	< 10 s													
3	85 ± 2	30 ± 3													

Note: More details can be found in the data book 'SIOV Metal Oxide Varistors', Ordering No. EPC: 62002-7600

© EPCOS AG 2002. Reproduction, publication and dissemination of this data sheet, enclosures hereto and the information contained therein without EPCOS' prior express consent is prohibited.

Purchase orders are subject to the General Conditions for the Supply of Products and Services of the Electrical and Electronics Industry recommended by the ZVEI (German Electrical and Electronic Manufacturers' Association), unless otherwise agreed.

ISSUE DATE	22.05.02	ISSUE	a	PUBLISHER	KH PE VAR	PAGE	6/6
------------	----------	-------	---	-----------	-----------	------	-----

Данный компонент на территории Российской Федерации

Вы можете приобрести в компании MosChip.

Для оперативного оформления запроса Вам необходимо перейти по данной ссылке:

<http://moschip.ru/get-element>

Вы можете разместить у нас заказ для любого Вашего проекта, будь то серийное производство или разработка единичного прибора.

В нашем ассортименте представлены ведущие мировые производители активных и пассивных электронных компонентов.

Нашей специализацией является поставка электронной компонентной базы двойного назначения, продукции таких производителей как XILINX, Intel (ex.ALTERA), Vicor, Microchip, Texas Instruments, Analog Devices, Mini-Circuits, Amphenol, Glenair.

Сотрудничество с глобальными дистрибьюторами электронных компонентов, предоставляет возможность заказывать и получать с международных складов практически любой перечень компонентов в оптимальные для Вас сроки.

На всех этапах разработки и производства наши партнеры могут получить квалифицированную поддержку опытных инженеров.

Система менеджмента качества компании отвечает требованиям в соответствии с ГОСТ Р ИСО 9001, ГОСТ РВ 0015-002 и ЭС РД 009

Офис по работе с юридическими лицами:

105318, г.Москва, ул.Щербаковская д.3, офис 1107, 1118, ДЦ «Щербаковский»

Телефон: +7 495 668-12-70 (многоканальный)

Факс: +7 495 668-12-70 (доб.304)

E-mail: info@moschip.ru

Skype отдела продаж:

moschip.ru

moschip.ru_4

moschip.ru_6

moschip.ru_9