

**HIGH-SPEED SATURATED SWITCH**

**DESCRIPTION**

The 2N2369A is a silicon planar epitaxial NPN transistor in Jedec TO-18 metal case. It is designed specifically for high-speed saturated switching applications at current levels from 100  $\mu$ A to 100 mA.

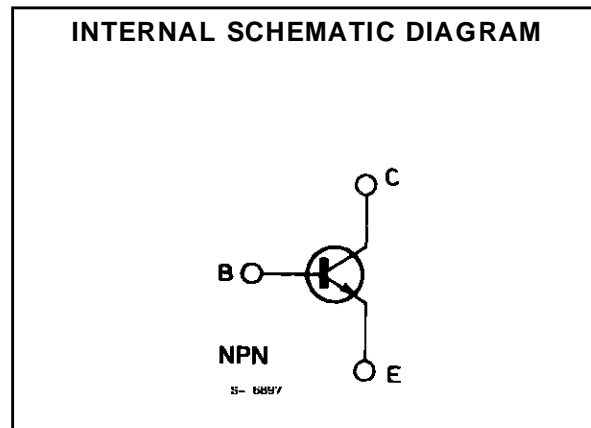
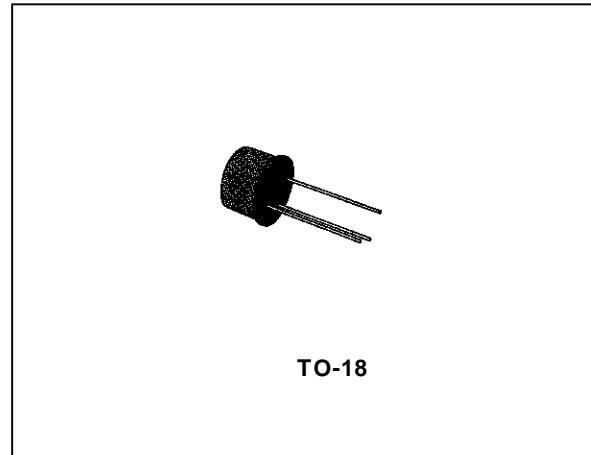

**ABSOLUTE MAXIMUM RATINGS**

Symbol	Parameter	Value	Unit
$V_{CBO}$	Collector-base Voltage ( $I_E = 0$ )	40	V
$V_{CES}$	Collector-emitter Voltage ( $V_{BE} = 0$ )	40	V
$V_{CEO}$	Collector-emitter Voltage ( $I_B = 0$ )	15	V
$V_{EBO}$	Emitter-base Voltage ( $I_C = 0$ )	4.5	V
$I_C$	Collector Current	0.2	A
$I_{CM}$	Collector Current (10 $\mu$ s pulse)	0.5	A
$P_{tot}$	Total Power Dissipation at $T_{amb} \leq 25^\circ\text{C}$	0.36	W
	at $T_{case} \leq 25^\circ\text{C}$	1.2	W
	at $T_{case} \leq 100^\circ\text{C}$	0.68	W
$T_{stg}, T_j$	Storage and Junction Temperature	- 65 to 200	$^\circ\text{C}$

**THERMAL DATA**

$R_{th\ j-case}$	Thermal Resistance Junction-case	Max	146	°C/W
$R_{th\ j-amb}$	Thermal Resistance Junction-ambient	Max	486	°C/W

**ELECTRICAL CHARACTERISTICS** ( $T_{amb} = 25\text{ °C}$  unless otherwise specified)

Symbol	Parameter	Test Conditions	Min.	Typ.	Max.	Unit
$I_{CBO}$	Collector Cutoff Current ( $I_E = 0$ )	$V_{CB} = 20\text{ V}$ $T_{amb} = 150\text{ °C}$			30	$\mu\text{A}$
$I_{CES}$	Collector Cutoff Current ( $V_{BE} = 0$ )	$V_{CE} = 20\text{ V}$			0.4	$\mu\text{A}$
$V_{(BR)CBO}$	Collector-base Breakdown Voltage ( $I_E = 0$ )	$I_C = 10\ \mu\text{A}$	40			V
$V_{(BR)CES}$	Collector-emitter Breakdown Voltage ( $V_{BE} = 0$ )	$I_C = 10\ \mu\text{A}$	40			V
$V_{(BR)CEO}^*$	Collector-emitter Breakdown Voltage ( $I_B = 0$ )	$I_C = 10\text{ mA}$	15			V
$V_{(BR)EBO}$	Emitter-base Breakdown Voltage ( $I_C = 0$ )	$I_E = 10\ \mu\text{A}$	4.5			V
$V_{CE(sat)}^*$	Collector-emitter Saturation Voltage	$I_C = 10\text{ mA}$ $I_B = 1\text{ mA}$ $I_C = 30\text{ mA}$ $I_B = 3\text{ mA}$ $I_C = 100\text{ mA}$ $I_B = 10\text{ mA}$ $I_C = 10\text{ mA}$ $I_B = 1\text{ mA}$ $T_{amb} = 125\text{ °C}$		0.14 0.17 0.28 0.19	0.2 0.25 0.5 0.3	V V V V
$V_{BE(sat)}^*$	Base-emitter Saturation Voltage	$I_C = 10\text{ mA}$ $I_B = 1\text{ mA}$ $I_B = 30\text{ mA}$ $I_B = 3\text{ mA}$ $I_C = 100\text{ mA}$ $I_B = 10\text{ mA}$ $I_C = 10\text{ mA}$ $I_B = 1\text{ mA}$ $T_{amb} = -55\text{ to }125\text{ °C}$	0.7  0.59	0.8 0.9 1.1	0.85 1.15 1.6 1.02	V V V V
$h_{FE}^*$	DC Current Gain	$I_C = 10\text{ mA}$ $V_{CE} = 0.35\text{ V}$ $I_C = 10\text{ mA}$ $V_{CE} = 1\text{ V}$ $I_C = 30\text{ mA}$ $V_{CE} = 0.4\text{ V}$ $I_C = 100\text{ mA}$ $V_{CE} = 1\text{ V}$	40 40 30 20	63 66 71	120 120	
$h_{FE}^*$	DC Current Gain	$I_C = 10\text{ mA}$ $V_{CE} = 0.35\text{ V}$ $T_{amb} = -55\text{ °C}$	20	50		
$f_T$	Transition Frequency	$I_C = 10\text{ mA}$ $V_{CE} = 10\text{ V}$ $f = 100\text{ MHz}$	500	675		MHz
$C_{CBO}$	Collector-base Capacitance	$I_E = 0$ $V_{CB} = 5\text{ V}$ $f = 1\text{ MHz}$		2.3	4	pF
$t_s^{**}$	Storage Time	$I_C = 10\text{ mA}$ $V_{CC} = 10\text{ V}$ $I_{B1} = -I_{B2} = 10\text{ mA}$		6	13	ns
$t_{on}^{**}$	Turn-on Time	$I_C = 10\text{ mA}$ $V_{CC} = 3\text{ V}$ $I_{B1} = 3\text{ mA}$		9	12	ns
$t_{off}^{**}$	Turn-off Time	$I_C = 10\text{ mA}$ $V_{CC} = 3\text{ V}$ $I_{B1} = 3\text{ mA}$ $I_{B2} = -1.5\text{ mA}$		13	18	ns

\* Pulsed : pulse duration = 300  $\mu\text{s}$ , duty cycle = 1 %.

DC Current Gain.

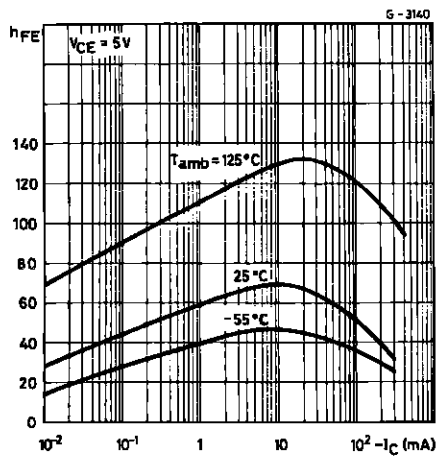

Collector-emitter Saturation Voltage.

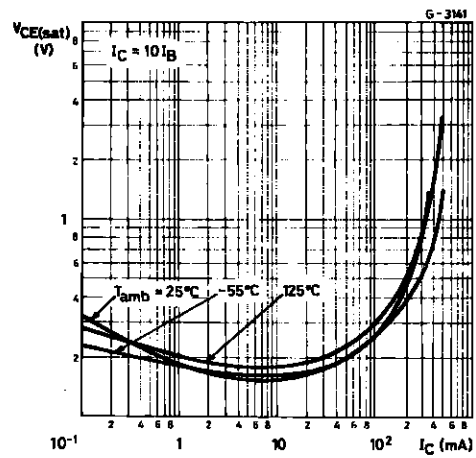

Collector-base and emitter-base capacitances.

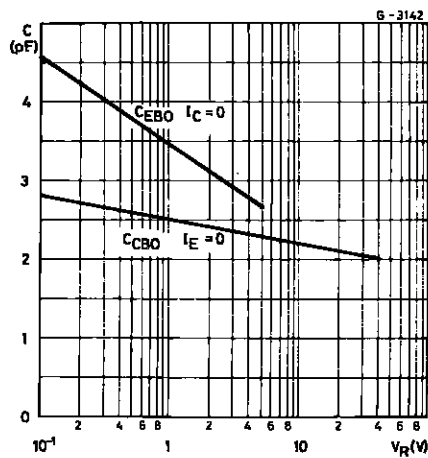

Contours of Constant Transition Frequency.

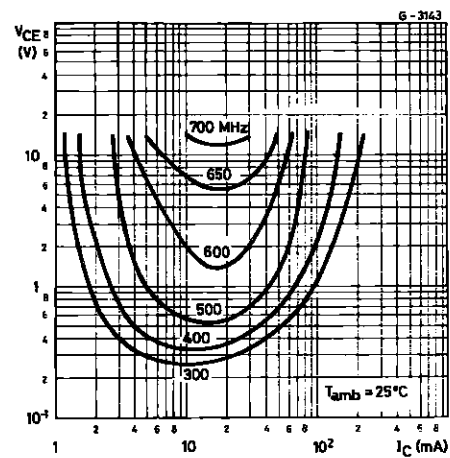

Switching Characteristics.

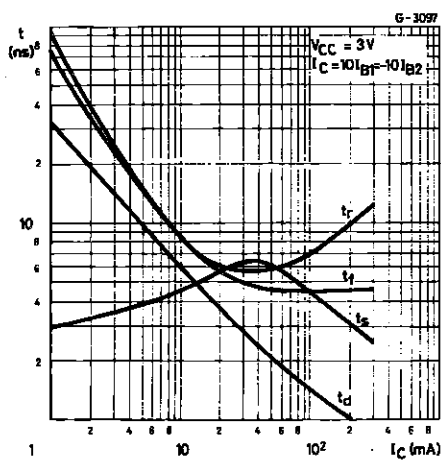

Switching Characteristics.

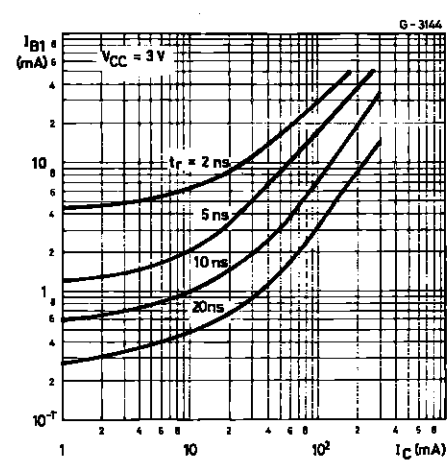

# 2N2369A

Test Circuit for  $t_s$

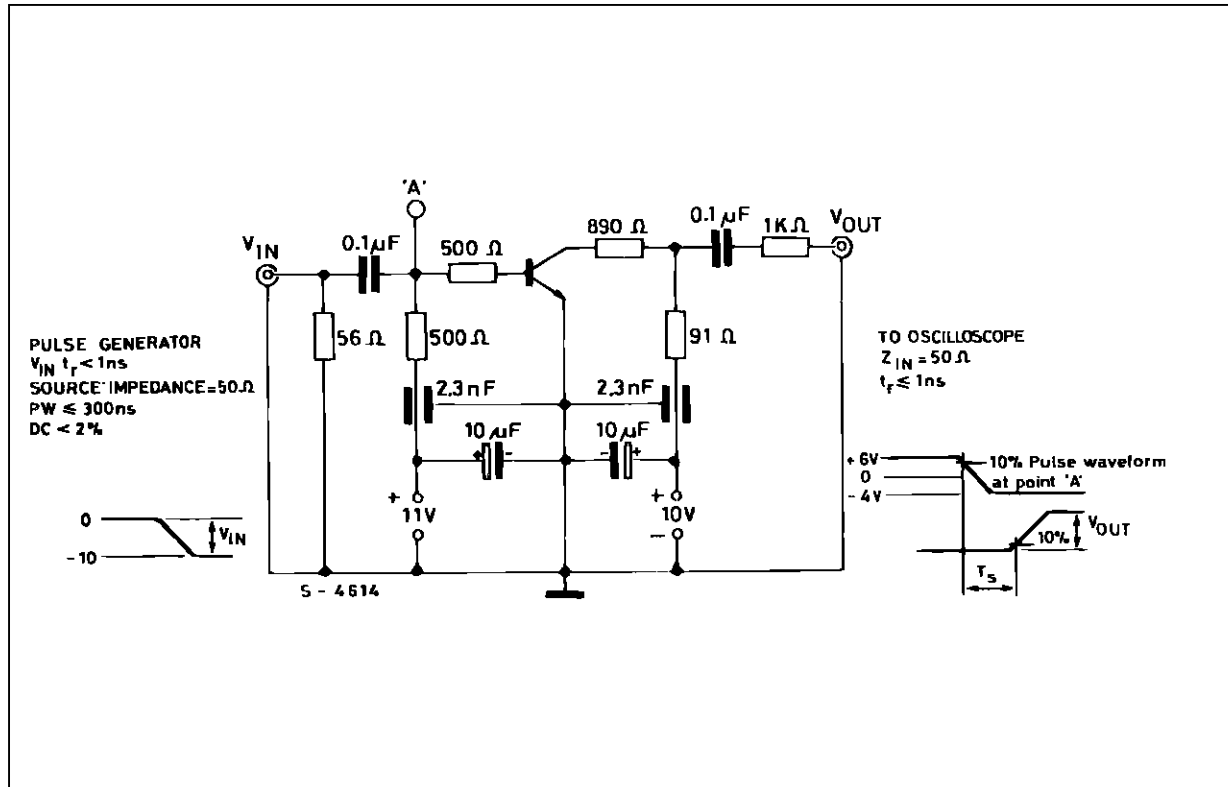

Test Circuit for  $t_{on}$ ,  $t_{off}$

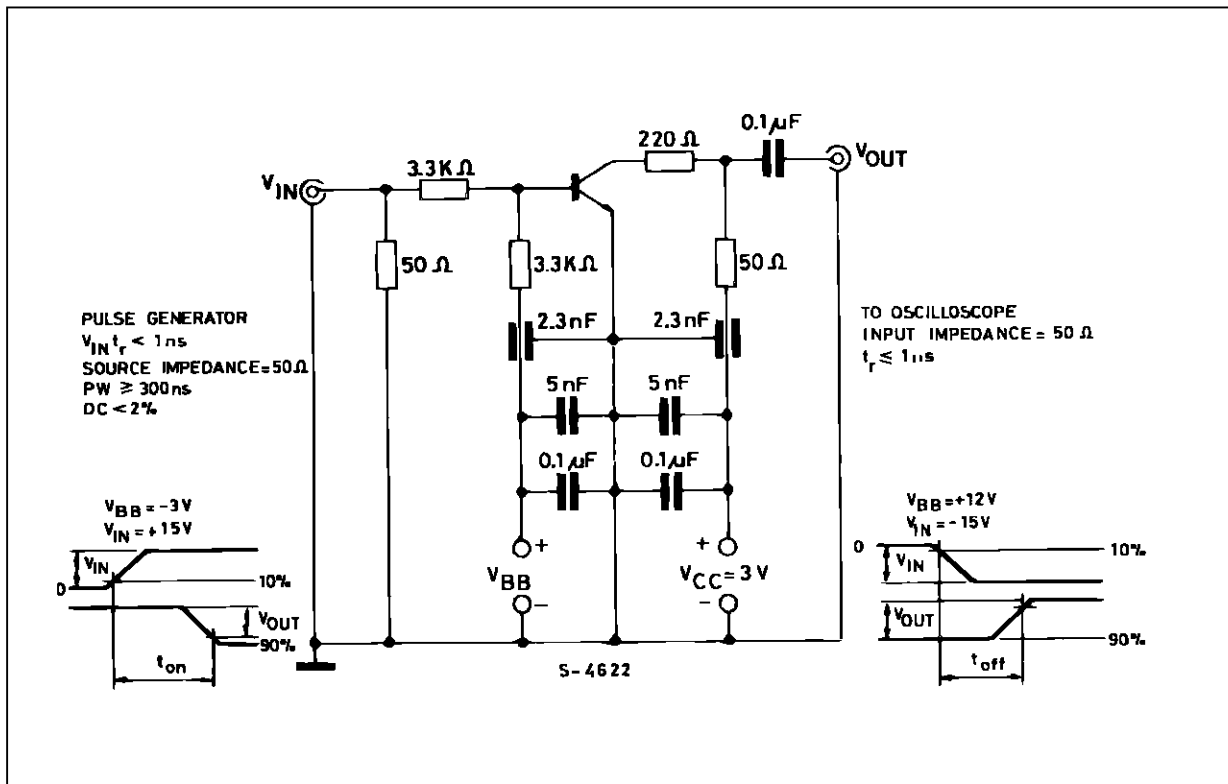

## TO-18 MECHANICAL DATA

DIM.	mm			inch		
	MIN.	TYP.	MAX.	MIN.	TYP.	MAX.
A		12.7			0.500	
B			0.49			0.019
D			5.3			0.208
E			4.9			0.193
F			5.8			0.228
G	2.54			0.100		
H			1.2			0.047
I			1.16			0.045
L	45°			45°		

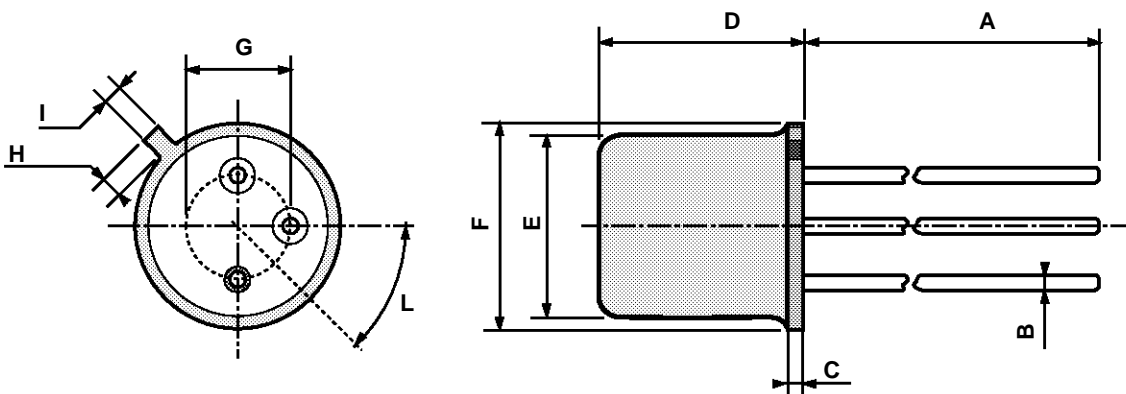

0016043

Information furnished is believed to be accurate and reliable. However, SGS-THOMSON Microelectronics assumes no responsibility for the consequences of use of such information nor for any infringement of patents or other rights of third parties which may result from its use. No license is granted by implication or otherwise under any patent or patent rights of SGS-THOMSON Microelectronics. Specifications mentioned in this publication are subject to change without notice. This publication supersedes and replaces all information previously supplied. SGS-THOMSON Microelectronics products are not authorized for use as critical components in life support devices or systems without express written approval of SGS-THOMSON Microelectronics.

© 1994 SGS-THOMSON Microelectronics - All Rights Reserved

SGS-THOMSON Microelectronics GROUP OF COMPANIES

Australia - Brazil - France - Germany - Hong Kong - Italy - Japan - Korea - Malaysia - Malta - Morocco - The Netherlands -  
Singapore - Spain - Sweden - Switzerland - Taiwan - Thailand - United Kingdom - U.S.A

## Данный компонент на территории Российской Федерации

### Вы можете приобрести в компании MosChip.

Для оперативного оформления запроса Вам необходимо перейти по данной ссылке:

<http://moschip.ru/get-element>

Вы можете разместить у нас заказ для любого Вашего проекта, будь то серийное производство или разработка единичного прибора.

В нашем ассортименте представлены ведущие мировые производители активных и пассивных электронных компонентов.

Нашей специализацией является поставка электронной компонентной базы двойного назначения, продукции таких производителей как XILINX, Intel (ex.ALTERA), Vicor, Microchip, Texas Instruments, Analog Devices, Mini-Circuits, Amphenol, Glenair.

Сотрудничество с глобальными дистрибьюторами электронных компонентов, предоставляет возможность заказывать и получать с международных складов практически любой перечень компонентов в оптимальные для Вас сроки.

На всех этапах разработки и производства наши партнеры могут получить квалифицированную поддержку опытных инженеров.

Система менеджмента качества компании отвечает требованиям в соответствии с ГОСТ Р ИСО 9001, ГОСТ РВ 0015-002 и ЭС РД 009

### Офис по работе с юридическими лицами:

105318, г.Москва, ул.Щербаковская д.3, офис 1107, 1118, ДЦ «Щербаковский»

Телефон: +7 495 668-12-70 (многоканальный)

Факс: +7 495 668-12-70 (доб.304)

E-mail: [info@moschip.ru](mailto:info@moschip.ru)

Skype отдела продаж:

moschip.ru

moschip.ru\_4

moschip.ru\_6

moschip.ru\_9