

PSE1000-PFC

1000 Watts
PFC Front End

Total Power: 1000 W
of Outputs: Single
Output: 390 V



Special Features

- 1000 W output power
- Unity power factor correction
- 3.5" x 2.4" x 1"
- 119 Watts per cubic inch
- Industrial safety
- -40 °C to 85 °C
- High efficiency: 94% typical
- Negative enable function
- Output OTP, OVP and power limit
- Current sharing and monitoring
- MIL-STD-810F for shock and vibration

Compliance

- EMI Class B (with external filter)
- EN61000 lunity
- RoHS 2

Safety

- UL 60950-1
508/1598/1433
60601-1 EO 3
- cUL 60950-1
- TUV 60950-1
60601
- CB Scheme Report/Cert

Electrical Specifications

Input	
Input range:	90 - 264 Vac (Operating) 115/230 Vac (Nominal)
Frequency:	47 - 63 Hz
Inrush current:	≤ 50 A peak at 230 Vac @ 25 deg C (with external resistor from INRUSH pin to OUTPUT -)
Power factor:	> 0.97 typical
Input current:	10.3 A RMS max input current, at 115 Vac
Hold up time:	16 ms minimum, at 115 Vrms AC input, full load with 680 uF/450 Vdc electrolytic capacitor
Efficiency:	> 94% typical at full load / 230 VAC nominal
ON/OFF power switch	Remote negative enable
Isolation:	PRI-Chassis 1500 Vac

Electrical Specifications

Output		
Output rating	390 Vdc	180 - 264 Vac
Set point		
Total regulation range	380 V to 400 Vdc 5 Vsb ± 1%	With 680 uF / 450 V electrolytic capacitor
Rated load	1000 W maximum	No derating up to 85 °C, Vin > 100 Vac
Minimum load	Main output @ 0.0 A	No loss of regulation
Output noise (PARD)	< 50 V max p-p	Full load at 680 uF / 450 V capacitor
Output voltage overshoot		No overshoot/undershoot outside the regulation band during ON or OFF cycle
Transient response	< 300 µSec	50% load step @ 1 A/µs Step load valid between 10% to 100% of output rating Recovery time to within 1% of set point at onset of transient
Max units in parallel	Up to 10	
Remote sense		Compensation up to 500 mV
Output isolation		Standard per safety requirements
Forced load sharing	To within 10% of all shared outputs	Analog sharing control
Overload protection (OCP)	140% to 160%	
Overvoltage protection (OVP)	110% to 135%	Latched until AC line recycle
Overtemp protection	102 - 107 °C baseplate temperature	Shut down and automatically restart when fault is removed

Environmental Specifications

Operating temperature:	-40 °C to +85 °C baseplate temperature
Storage temperature	-40 °C to +100 °C
Humidity	10 to 100% non-condensing operating
Altitude	Operating - 13,000 feet, derating 1 degree C per 1000 feet above 10,000 feet Storage - 50,000 feet
Shock	MIL-STD-810F 516.5,
Vibration	MIL-STD-810F 514.5, Cat, IEC68-2-6

Ordering Information

Model Number	Output	Nominal Output Voltage Set Point	Current		Output Ripple P/P 0-50 deg C	Max Continuous Power	Combined Line/ Load Regulation
			Min	Max			
PSE1000PFC	390 V	390 V	0 A	2.82 A	< 50 V	1000	2.5%

Mechanical Drawing

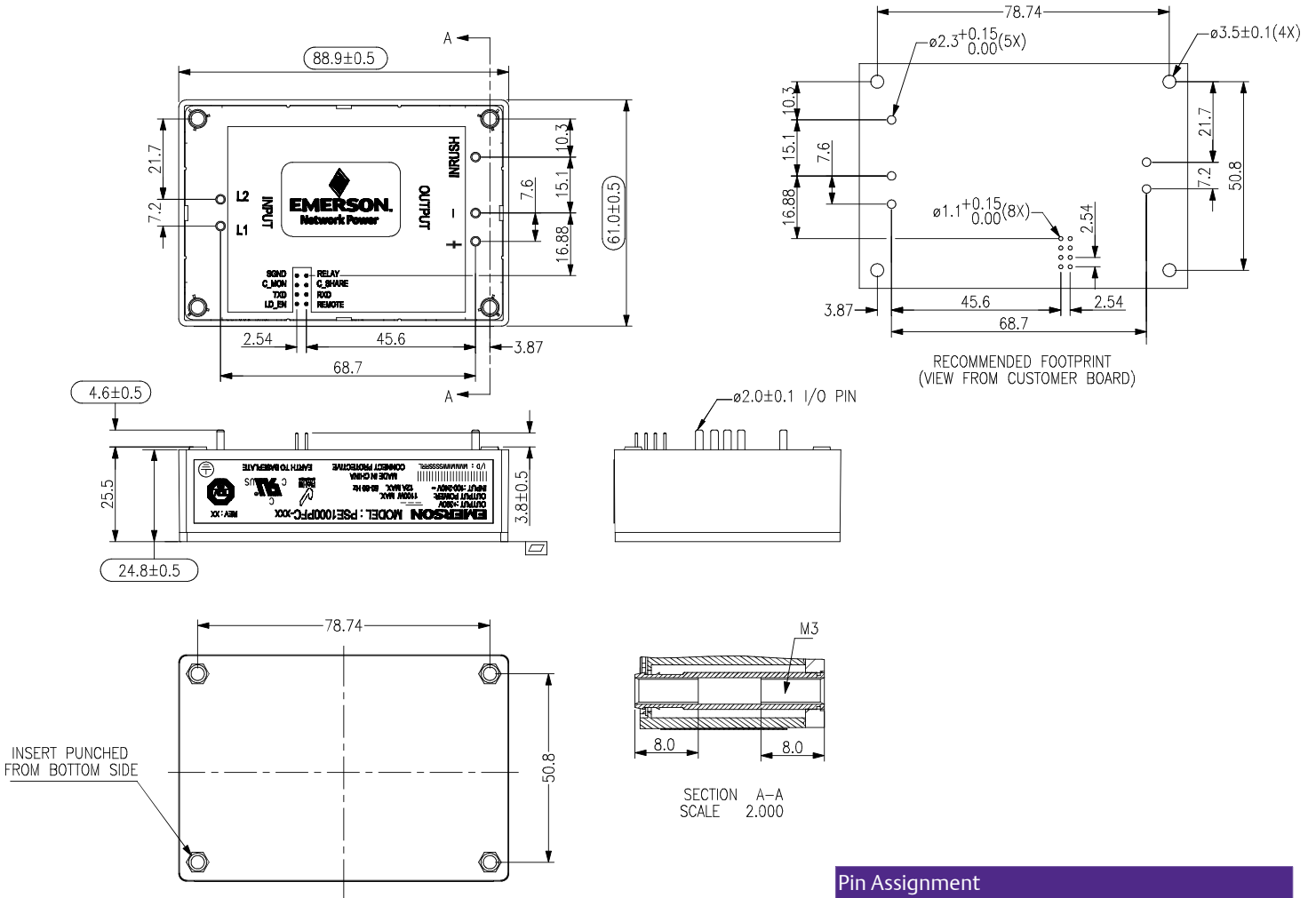

Pin Assignment	
Signal Type	Description
L1	AC input
L2	AC input
S GND	Signal ground
C. Mon	Current monitoring
TXD	Digital communication
LD EN	Load Enable
Relay	
C. Share	Current Share
RXD	Digital communication
Remote	Remote ON/OFF
INRUSH	Limit Inrush Current
Output +	DC Output +
Output -	DC Output -

Miscellaneous Specifications

Burn-In

100% Burn-in at 45 °C, at 80 - 90% load. Duration of burn-in determined by Quality Assurance Procedures

MTBF

The power supply has a minimum MTBF of 300K hours using the Bell core 332, issue 6 specification @ 25 °C and 40 °C, ambient, at full load. With the power supply installed in a system in a 25 °C ambient environment and operating at full load, capacitor life shall be 10 years, minimum for ALL electrolytic capacitors contained within this power supply. The power supply shall demonstrate a MTBF level of > 500,000 hours.

Quality Assurance

Full QAV testing shall be conducted in accordance with Emerson Network Power Standards with reports available upon request.

Warranty

Emerson Network Power shall warrant the power supply to be free of defects in materials and workmanship for a minimum period of **three years** from the date of shipment, when operated within specifications. The warranty shall be fully transferable to the end owner of the equipment powered by the supply.

Americas

5810 Van Allen Way
Carlsbad, CA 92008
USA
Telephone: +1 760 930 4600
Facsimile: +1 760 930 0698

Europe (UK)

Waterfront Business Park
Merry Hill, Dudley
West Midlands, DY5 1LX
United Kingdom
Telephone: +44 (0) 1384 842 211
Facsimile: +44 (0) 1384 843 355

Asia (HK)

14/F, Lu Plaza
2 Wing Yip Street
Kwun Tong, Kowloon
Hong Kong
Telephone: +852 2176 3333
Facsimile: +852 2176 3888

For global contact, visit:

www.Emerson.com/EmbeddedPower
techsupport.embeddedpower@emerson.com

While every precaution has been taken to ensure accuracy and completeness in this literature, Emerson Network Power assumes no responsibility, and disclaims all liability for damages resulting from use of this information or for any errors or omissions.

Emerson Network Power.
The global leader in enabling
business-critical continuity.

- AC Power
- Connectivity
- DC Power
- Embedded Computing
- **Embedded Power**
- Monitoring
- Outside Plant
- Power Switching & Controls
- Precision Cooling
- Racks & Integrated Cabinets
- Services
- Surge Protection

EmersonNetworkPower.com

Emerson and the Emerson Network Power logo are trademarks of Emerson Electric Co.
©2013 Emerson Electric Co.
All rights reserved.

Данный компонент на территории Российской Федерации

Вы можете приобрести в компании MosChip.

Для оперативного оформления запроса Вам необходимо перейти по данной ссылке:

<http://moschip.ru/get-element>

Вы можете разместить у нас заказ для любого Вашего проекта, будь то серийное производство или разработка единичного прибора.

В нашем ассортименте представлены ведущие мировые производители активных и пассивных электронных компонентов.

Нашей специализацией является поставка электронной компонентной базы двойного назначения, продукции таких производителей как XILINX, Intel (ex.ALTERA), Vicor, Microchip, Texas Instruments, Analog Devices, Mini-Circuits, Amphenol, Glenair.

Сотрудничество с глобальными дистрибьюторами электронных компонентов, предоставляет возможность заказывать и получать с международных складов практически любой перечень компонентов в оптимальные для Вас сроки.

На всех этапах разработки и производства наши партнеры могут получить квалифицированную поддержку опытных инженеров.

Система менеджмента качества компании отвечает требованиям в соответствии с ГОСТ Р ИСО 9001, ГОСТ РВ 0015-002 и ЭС РД 009

Офис по работе с юридическими лицами:

105318, г.Москва, ул.Щербаковская д.3, офис 1107, 1118, ДЦ «Щербаковский»

Телефон: +7 495 668-12-70 (многоканальный)

Факс: +7 495 668-12-70 (доб.304)

E-mail: info@moschip.ru

Skype отдела продаж:

moschip.ru

moschip.ru_4

moschip.ru_6

moschip.ru_9