



## DT SERIES ELEMENTS WITH LEAD ATTACHMENT

### SPECIFICATIONS

- ◆ Piezoelectric film sensor
- ◆ AC Coupled
- ◆ Silver Ink Electrodes
- ◆ Protective Coating over Electrodes
- ◆ Lead Wires Attached with Rivets.

The DT Series of Piezo film sensors elements are rectangular elements of Piezo film with silver ink screen printed electrodes. They are available in a variety of different sizes and thicknesses. Lead attachment is accomplished using a riveted lug going to 12" (300 mm) of 28 AWG wire.

The DT film element produces more than 10 millivolts per micro-strain. The capacitance is proportional to the area and inversely proportional to the thickness of the element.

The DT elements are supplied with a thin protective coating over the active electrode area to prevent oxidation to the top surface of the silver ink.

### FEATURES

- ◆ Minimum Impedance: 1 MΩ
- ◆ Preferred Impedance: 10 MΩ and higher
- ◆ Output Voltage: 10 mV to 100V depending on Force and Circuit Impedance
- ◆ Storage Temperature: -40°C to +70°C [-40°F to 60°F]
- ◆ Operating Temperature: 0°C to +70°C [32°F to 160°F]

### APPLICATIONS

- ◆ Sensing Direct Contact Force
- ◆ Recording Time of an Event
- ◆ Counting Number of Impact Events
- ◆ Measuring Impact Related Events

### TYPICAL PIEZO FILM PROPERTIES

Symbol	Parameter	PVDF	Units
t	Thickness	28, 52	μm
d <sub>31</sub>	Piezo Strain Constant	23	(10 <sup>-12</sup> )C/N
d <sub>33</sub>		-33	
g <sub>31</sub>	Piezo Stress constant	216	(10 <sup>-3</sup> )Vm/N
g <sub>33</sub>		-330	
k <sub>31</sub>	Electromechanical Coupling Factor	12%	
k <sub>t</sub>		14%	
C	Capacitance	380 for 28μm	pF/cm <sup>2</sup> . @ 1KHz
Y	Young's Modulus	2-4	10 <sup>9</sup> N/m <sup>2</sup>
V <sub>0</sub>	Speed of Sound	2.2	10 <sup>3</sup> m/s in thickness direction

## DT SERIES ELEMENTS WITH LEAD ATTACHMENT

### DIMENSIONS and PART NUMBERS

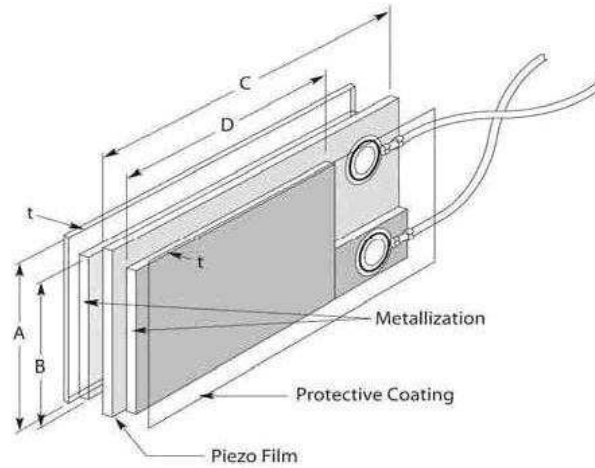

Dimensions in inches (mm)

Model Number	Part Number	Film Thickness	A Film	B Electrode	C Film	D Electrode	Total Thickness (µm)	Cap (nF)
DT1-028K/L w/rivets	1-1002908-0	28 µm	.64 (16)	.484 (12)	1.63 (41)	1.19 (30)	40	1.38
DT1-052K/L w/rivets	2-1002908-0	52 µm	.64 (16)	.484 (12)	1.63 (41)	1.19 (30)	64	.740
DT2-028K/L w/rivets	1-1003744-0	28 µm	.64 (16)	.484 (12)	2.86 (73)	2.42 (62)	40	2.78
DT2-052K/L w/rivets	2-1003744-0	52 µm	.64 (16)	.484 (12)	2.86 (73)	2.42 (62)	64	1.44
DT4-028K/L w/rivets	1-1002150-0	28 µm	.86 (22)	.740 (19)	6.72 (171)	6.72 (171)	40	11.00
DT4-052K/L w/rivets	2-1002150-0	52 µm	.86 (22)	.740 (19)	6.72 (171)	6.72 (171)	64	5.70

#### NORTH AMERICA

Measurement Specialties, Inc.,  
a TE Connectivity Company  
Tel: +1-800-522-6752  
Email: [customercare.dtmd@te.com](mailto:customercare.dtmd@te.com)

#### EUROPE

MEAS Deutschland GmbH  
a TE Connectivity Company  
Tel: +49-800-440-5100  
Email: [customercare.dtmd@te.com](mailto:customercare.dtmd@te.com)

#### ASIA

Measurement Specialties (China), Ltd.,  
a TE Connectivity Company  
Tel: +86 0400-820-6015  
Email: [customercare.chdu@te.com](mailto:customercare.chdu@te.com)

#### TE.com/sensorsolutions

Measurement Specialties, Inc., a TE Connectivity company.

Measurement Specialties, TE Connectivity, TE Connectivity (logo) and EVERY CONNECTION COUNTS are trademarks. All other logos, products and/or company names referred to herein might be trademarks of their respective owners.

The information given herein, including drawings, illustrations and schematics which are intended for illustration purposes only, is believed to be reliable. However, TE Connectivity makes no warranties as to its accuracy or completeness and disclaims any liability in connection with its use. TE Connectivity's obligations shall only be as set forth in TE Connectivity's Standard Terms and Conditions of Sale for this product and in no case will TE Connectivity be liable for any incidental, indirect or consequential damages arising out of the sale, resale, use or misuse of the product. Users of TE Connectivity products should make their own evaluation to determine the suitability of each such product for the specific application.

© 2015 TE Connectivity Ltd. family of companies All Rights Reserved.

## Данный компонент на территории Российской Федерации

### Вы можете приобрести в компании MosChip.

Для оперативного оформления запроса Вам необходимо перейти по данной ссылке:

<http://moschip.ru/get-element>

Вы можете разместить у нас заказ для любого Вашего проекта, будь то серийное производство или разработка единичного прибора.

В нашем ассортименте представлены ведущие мировые производители активных и пассивных электронных компонентов.

Нашей специализацией является поставка электронной компонентной базы двойного назначения, продукции таких производителей как XILINX, Intel (ex.ALTERA), Vicor, Microchip, Texas Instruments, Analog Devices, Mini-Circuits, Amphenol, Glenair.

Сотрудничество с глобальными дистрибьюторами электронных компонентов, предоставляет возможность заказывать и получать с международных складов практически любой перечень компонентов в оптимальные для Вас сроки.

На всех этапах разработки и производства наши партнеры могут получить квалифицированную поддержку опытных инженеров.

Система менеджмента качества компании отвечает требованиям в соответствии с ГОСТ Р ИСО 9001, ГОСТ РВ 0015-002 и ЭС РД 009

### Офис по работе с юридическими лицами:

105318, г.Москва, ул.Щербаковская д.3, офис 1107, 1118, ДЦ «Щербаковский»

Телефон: +7 495 668-12-70 (многоканальный)

Факс: +7 495 668-12-70 (доб.304)

E-mail: [info@moschip.ru](mailto:info@moschip.ru)

Skype отдела продаж:

moschip.ru

moschip.ru\_4

moschip.ru\_6

moschip.ru\_9