

MAX40002–MAX40005 Evaluation Kits

Evaluates: MAX40002–MAX40005
MAX40012–MAX40015

General Description

The MAX40002–MAX40005 evaluation kits (EV kits) are fully assembled and tested PC boards that evaluate the MAX40002ANS02–MAX40005ANS02 single comparators. The MAX40002ANS02–MAX40005ANS02 operate from a V_{CC} supply between 1.7V to 5.5V, come with an internal reference voltage of 0.2V, and have a wide 0.1V to 5.5V input voltage (IN) range. These EV kits demonstrate the MAX40002ANS02–MAX40005ANS02 in an ultra-small, 0.76mm x 0.76mm, 4-bump wafer-level package (WLP) with 0.35mm bump spacing.

These EV kits are configured to evaluate all devices in the MAX40002–MAX40005/MAX40012–MAX40015 family that have a 4-bump wafer-level package (WLP). To evaluate other WLP devices in this MAX40002–MAX40005/MAX40012–MAX40015 family other than what is pre-installed, replace the U1 IC with the desired part (see [Ordering Information](#) for details).

Features

- 0.1V to 5.5V Input Voltage Range
- 1.7V to 5.5V External Reference Range (MAX40002ANS–MAX40005ANS)
- 1.7V to 5.5V V_{CC} Range with Internal Reference (MAX40002ANS__–MAX40005ANS__)
 - 0.2V, 0.5V, 0.9V, and 1.222V Internal Reference Options Available
- Evaluates 4-Bump WLP Package
- Fully Assembled and Tested

[Ordering Information](#) appears at the end of the data sheet.

Quick Start

Required Equipment

Before beginning, the following equipment is needed:

- Three +5V DC power supplies (V_{CC} /REF, IN, and V_{PU})
- One digital multimeter (DMM)

Procedure

The MAX40002–MAX40005 EV kits are fully assembled and tested. Follow these steps to verify board operation. **Do not turn on the power supply until all connections are completed.**

- 1) Connect the positive terminal of a DC power supply to the V_{CC} pad and the ground terminal to the GND pad.
- 2) Connect the positive terminal of a DC power supply to the V_{PU} pad and the ground terminal to the GND pad (MAX40002/MAX40003/MAX40012/MAX40013 only).
- 3) Connect the positive terminal of a DC power supply to the IN pad and the ground terminal to the GND pad.
- 4) Turn on the V_{CC} power supply and set it to the desired level.
- 5) Turn on the V_{PU} power supply and set it to the desired level (MAX40002/MAX40003/MAX40012/MAX40013 only).
- 6) Turn on the IN power supply and set it to the desired level.
- 7) Monitor the output using a DMM at the OUT pad, and study its response to varying voltage at IN (see [Table 1](#) for more information).

Table 1. How Devices Behave Under Various Input Voltage Conditions

PART	V _{REF}	INPUT POLARITY	INPUT VOLTAGE CONDITIONS	ACTION AT OUTPUT
MAX40002, MAX40004 MAX40012, MAX40014	External	Noninverting	V _{IN} > V _{REF}	Output goes high
			V _{IN} < V _{REF}	Output goes low
Inverting		V _{IN} > V _{REF}	Output goes low	
		V _{IN} < V _{REF}	Output goes high	
MAX40003, MAX40005 MAX40013, MAX40015	Internal	Noninverting	V _{IN} > V _{REF_INT}	Output goes high
			V _{IN} < V _{REF_INT}	Output goes low
Inverting		V _{IN} > V _{REF_INT}	Output goes low	
		V _{IN} < V _{REF_INT}	Output goes high	

Detailed Description of Hardware

The MAX40002–MAX40005 EV kits are fully assembled and tested PC boards that evaluate the 4-bump WLP MAX40002ANS02–MAX40005ANS02 comparators.

V_{CC}/REF Supply Selection

The V_{CC}/REF pad on the EV kit is used to either supply a 1.7V to 5.5V V_{CC} voltage (internal reference devices) or a 1.7V to 5.5V external reference voltage to the IC. Refer to the MAX40002–MAX40005 and MAX40012–MAX40015 data sheets for more information.

V_{PU} Pad

The V_{PU} pad on the EV kit is used to connect a pullup supply voltage up to 5.5V for the open-drain output devices (MAX40002/MAX40003/MAX40012/MAX40013) for proper operation. Remove R1 and eliminate V_{PU} if evaluating the push-pull output devices (MAX40004/MAX40005/MAX40014/MAX40015).

Ordering Information

PART*	U1 IC (INSTALLED)	V _{REF} (V)	TYPE	SWAP U1 IC TO EVALUATE
MAX40002EVKIT#	MAX40002ANS02+	0.2	EV Kit	MAX40012
MAX40003EVKIT#	MAX40003ANS02+	0.2	EV Kit	MAX40013
MAX40004EVKIT#	MAX40004ANS02+	0.2	EV Kit	MAX40014
MAX40005EVKIT#	MAX40005ANS02+	0.2	EV Kit	MAX40015

#Denotes RoHS-compliant

MAX40002–MAX40005 EV Kit Bill of Materials*

ITEM	REF_DES	DNI/ DNP	QTY	MFG PART #	MFCTR	VALUE	DESCRIPTION
1	C1	-	1	GRM21BR71A475KA73; LMK212B7475KG-T	MURATA/TAIYO YUDEN	4.7UF	CAPACITOR; SMT (0805); CERAMIC CHIP; 4.7UF; 10V; TOL=10%; MODEL=GRM SERIES; TG=-55 DEGC TO +125 DEGC; TC=X7R
2	C2, C4	-	2	C1608X7R1E104K080AA	TDK	0.1UF	CAPACITOR; SMT (0603); CERAMIC CHIP; 0.1UF; 25V; TOL=10%; MODEL=C SERIES; TG=-55 DEGC TO +125 DEGC; TC=X7R
3	GND, TP1, TP2	-	3	5006	KEYSTONE	N/A	TEST POINT; PIN DIA=0.125IN; TOTAL LENGTH=0.35IN; BOARD HOLE=0.063IN; BLACK; PHOSPHOR BRONZE WIRE SILVER PLATE FINISH;
4	IN, OUT, VCC, VPU	-	4	5005	KEYSTONE	N/A	TEST POINT; PIN DIA=0.125IN; TOTAL LENGTH=0.35IN; BOARD HOLE=0.063IN; RED; PHOSPHOR BRONZE WIRE SILVER PLATE FINISH;
5	U1	-	1	MAX40004ANS+	MAXIM	MAX40004ANS+	EVKIT PART-IC; COMP; 600NA; 4-BUMP ULTRA-TINY COMPARATOR; PACKAGE OUTLINE: 21-100103; PACKAGE CODE: N40C0+1; WLP4
6	C3	DNP	0	C1608X7R1E104K080AA	TDK	0.1UF	CAPACITOR; SMT (0603); CERAMIC CHIP; 0.1UF; 25V; TOL=10%; MODEL=C SERIES; TG=-55 DEGC TO +125 DEGC; TC=X7R
7	R1, R2	DNP	0	ERA-3ARB104	PANASONIC	100K	RESISTOR; 0603; 100K OHM; 0.1%; 10PPM; 0.1W; THIN FILM
8	PCB	-	1	MAX40004	MAXIM	PCB	PCB Board:MAX40004 EVALUATION KIT
TOTAL			12				

*Specified for the MAX40004. For other variants, change U1 to the desired device. All other components are the same.

MAX40002–MAX40005
Evaluation Kits

Evaluates: MAX40002–MAX40005
MAX40012–MAX40015

MAX40002–MAX40005 EV Kit PCB Layout Diagrams*

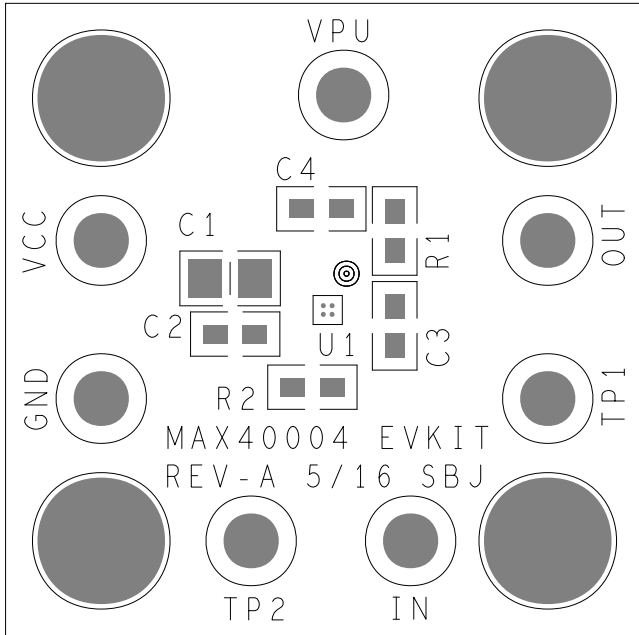

MAX40002–MAX40005 EV Kit—Top Silkscreen

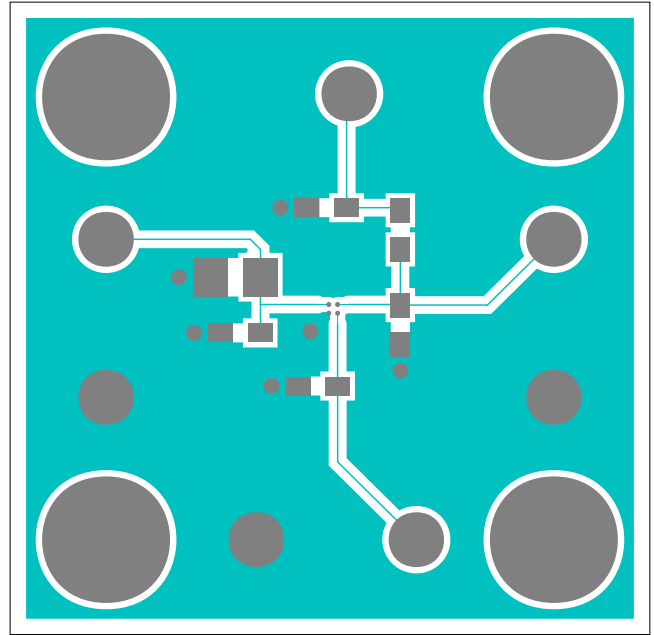

MAX40002–MAX40005 EV Kit—Top

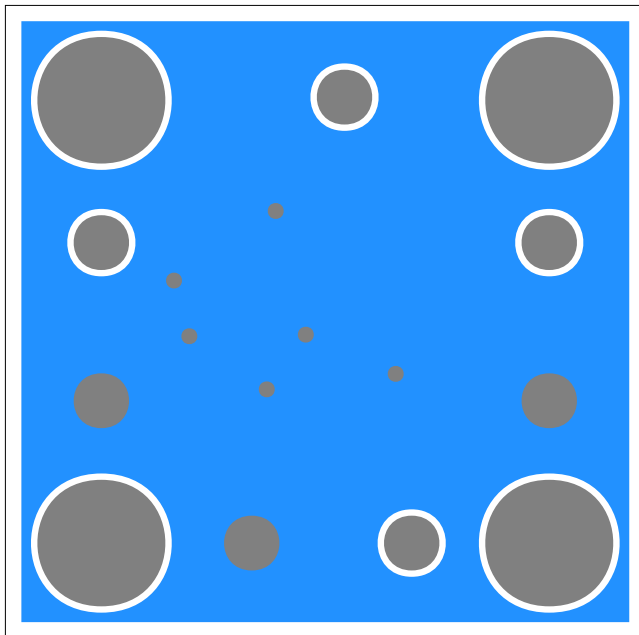

MAX40002–MAX40005 EV Kit—Bottom



MAX40002–MAX40005 EV Kit—Bottom Silkscreen

*Specified for the MAX40004. For other variants, change U1 to the desired device. All other components are the same.

MAX40002–MAX40005 EV Kit Schematic*

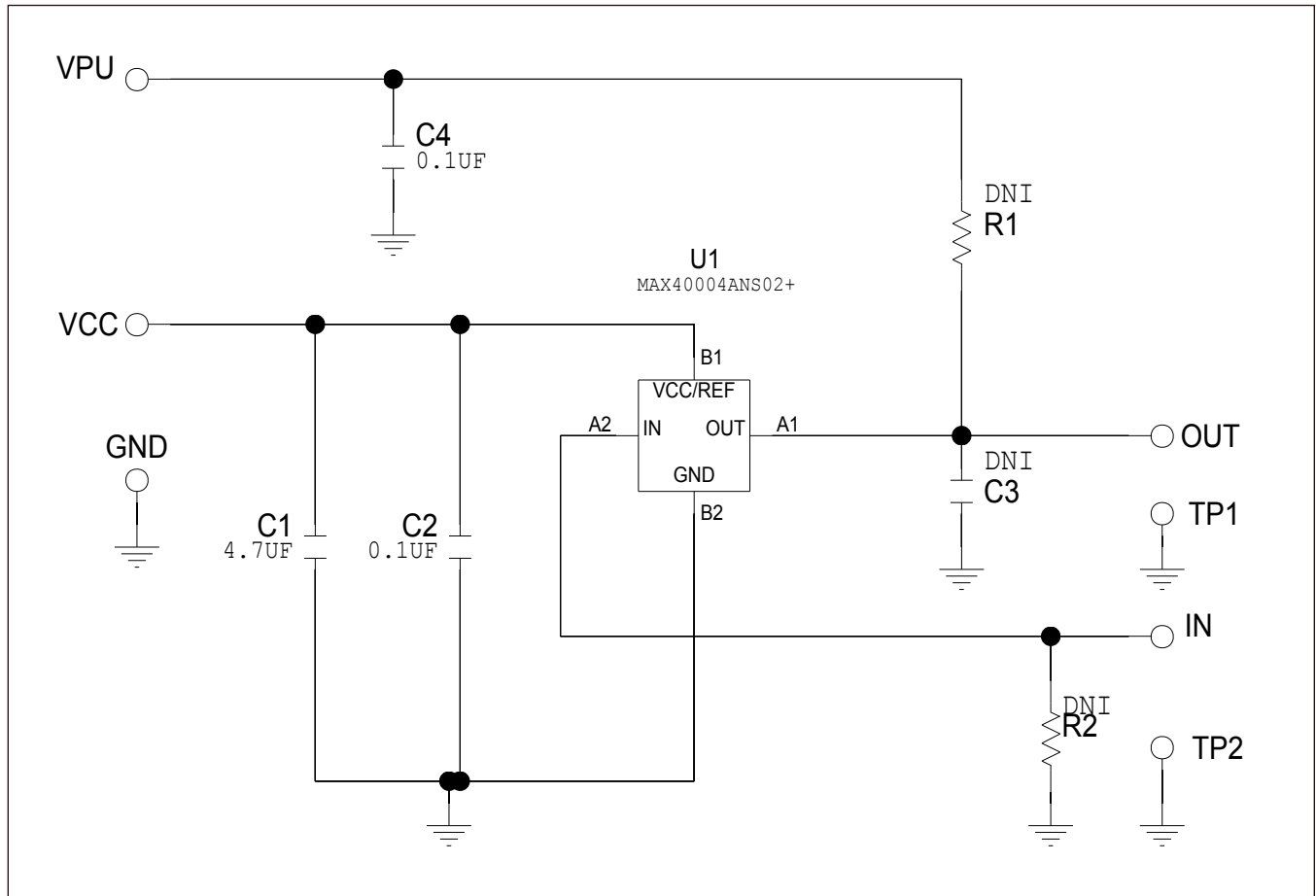

*Specified for the MAX40004. For other variants, change U1 to the desired device. All other components are the same.

MAX40002–MAX40005
Evaluation Kits

Evaluates: MAX40002–MAX40005
MAX40012–MAX40015

Revision History

REVISION NUMBER	REVISION DATE	DESCRIPTION	PAGES CHANGED
0	1/17	Initial release	—
1	2/20	Added MAX40012–MAX40015 part numbers to data sheet	1–6

For pricing, delivery, and ordering information, please visit Maxim Integrated's online storefront at <https://www.maximintegrated.com/en/storefront/storefront.html>.

Maxim Integrated cannot assume responsibility for use of any circuitry other than circuitry entirely embodied in a Maxim Integrated product. No circuit patent licenses are implied. Maxim Integrated reserves the right to change the circuitry and specifications without notice at any time.

Данный компонент на территории Российской Федерации

Вы можете приобрести в компании MosChip.

Для оперативного оформления запроса Вам необходимо перейти по данной ссылке:

<http://moschip.ru/get-element>

Вы можете разместить у нас заказ для любого Вашего проекта, будь то серийное производство или разработка единичного прибора.

В нашем ассортименте представлены ведущие мировые производители активных и пассивных электронных компонентов.

Нашей специализацией является поставка электронной компонентной базы двойного назначения, продукции таких производителей как XILINX, Intel (ex.ALTERA), Vicor, Microchip, Texas Instruments, Analog Devices, Mini-Circuits, Amphenol, Glenair.

Сотрудничество с глобальными дистрибьюторами электронных компонентов, предоставляет возможность заказывать и получать с международных складов практически любой перечень компонентов в оптимальные для Вас сроки.

На всех этапах разработки и производства наши партнеры могут получить квалифицированную поддержку опытных инженеров.

Система менеджмента качества компании отвечает требованиям в соответствии с ГОСТ Р ИСО 9001, ГОСТ РВ 0015-002 и ЭС РД 009

Офис по работе с юридическими лицами:

105318, г.Москва, ул.Щербаковская д.3, офис 1107, 1118, ДЦ «Щербаковский»

Телефон: +7 495 668-12-70 (многоканальный)

Факс: +7 495 668-12-70 (доб.304)

E-mail: info@moschip.ru

Skype отдела продаж:

moschip.ru

moschip.ru_4

moschip.ru_6

moschip.ru_9