

MAX2871

23.5MHz to 6000MHz Fractional/Integer-N Synthesizer/VCO

General Description

The MAX2871 is an ultra-wideband phase-locked loop (PLL) with integrated voltage control oscillators (VCOs) capable of operating in both integer-N and fractional-N modes. When combined with an external reference oscillator and loop filter, the MAX2871 is a high-performance frequency synthesizer capable of synthesizing frequencies from 23.5MHz to 6.0GHz while maintaining superior phase noise and spurious performance.

The ultra-wide frequency range is achieved with the help of multiple integrated VCOs covering 3000MHz to 6000MHz, and output dividers ranging from 1 to 128. The device also provides dual differential output drivers, which can be independently programmed to deliver -1dBm to +8dBm differential output power. Both outputs can be muted by either software or hardware control.

The MAX2871 is controlled by a 3-wire serial interface and is compatible with 1.8V control logic. The device is available in a lead-free, RoHS-compliant, 5mm x 5mm, 32-pin TQFN package, and operates over an extended -40°C to +85°C temperature range.

The MAX2871 has an improved feature set and better overall phase noise and is fully pin- and software- compatible with the MAX2870.

Applications

- Wireless Infrastructure
- Clock Generation
- Test and Measurement
- Microwave Radios

Functional Diagram

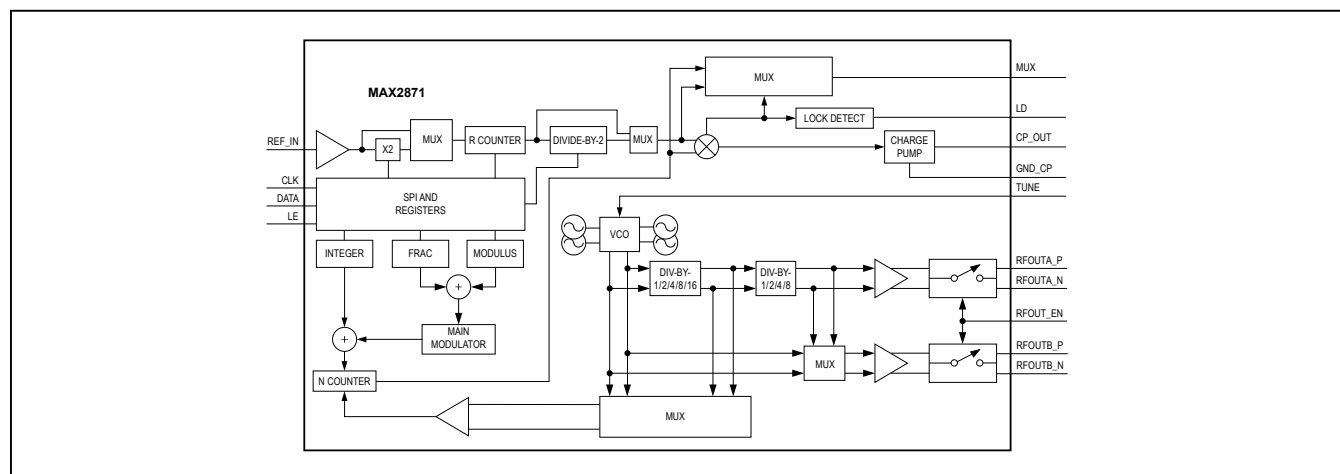

Benefits and Features

- Output Binary Buffers/Dividers Enable Extended Frequency Range
 - Divider Ratios of 1/2/4/8/16/32/64/128
 - 23.5MHz to 6000MHz
- High-Performance Phase Frequency Detector (PFD) and Reference Frequency Reduces Spectral Noise
 - PFD Up to 140MHz
 - Reference Frequency Up to 210MHz
- Low Normalized Inband Phase Noise of -230dBc/Hz Reduces System Noise Floor Contribution
- Manual or Automatic VCO Selection Permits Fast Switching
- Output Phase Reset and Adjustment Allow Synchronization of Multiple Synthesizers
- On-Chip Temperature Sensor with 7-Bit ADC Ensures Optimum VCO Selection
- Cycle Slip Reduction and Fast Lock Features Improve Accuracy and Acquisition Time
- VCO Lock Maintained Over Entire Temperature Range Provides Glitch-Free Operation
- Dual Differential Programmable Outputs Maximize Flexibility of Use

Ordering Information and Typical Application Circuit appears at end of data sheet.

Absolute Maximum Ratings

| | | | |
|---|----------------------------------|--|-----------------|
| V _{CC_} to GND_..... | -0.3V to +3.9V | Junction Temperature..... | +150°C |
| All Other Pins to GND_..... | -0.3V to V _{CC_} + 0.3V | Operating Temperature Range..... | -40°C to +85°C |
| Continuous Power Dissipation (T _A = +70°C) | | Storage Temperature Range..... | -65°C to +150°C |
| TQFN-EP Multilayer Board | | Lead Temperature (soldering, 10s)..... | +300°C |
| (derate 34.5mW/°C above +70°C)..... | 2758.6mW | Soldering Temperature (reflow)..... | +260°C |

Stresses beyond those listed under "Absolute Maximum Ratings" may cause permanent damage to the device. These are stress ratings only, and functional operation of the device at these or any other conditions beyond those indicated in the operational sections of the specifications is not implied. Exposure to absolute maximum rating conditions for extended periods may affect device reliability.

Package Thermal Characteristics (Note 1)

TQFN

| | | | |
|--|--------|---|---------|
| Junction-to-Ambient Thermal Resistance (θ _{JA})..... | 29°C/W | Junction-to-Case Thermal Resistance (θ _{JC})..... | 1.7°C/W |
|--|--------|---|---------|

Note 1: Package thermal resistances were obtained using the method described in JEDEC specification JESD51-7, using a four-layer board. For detailed information on package thermal considerations, refer to www.maximintegrated.com/thermal-tutorial.

DC Electrical Characteristics

(Measured using MAX2871 EV Kit. V_{CC_} = 3V to 3.6V, V_{GND_} = 0V, f_{REF_IN} = 50MHz, f_{PFD} = 50MHz, T_A = -40°C to +85°C. Typical values measured at V_{CC_} = 3.3V; T_A = +25°C; register settings 00780000, 20000141, 01005E42, 00000013, 610F423C, 01400005; unless otherwise noted.) (Note 2)

| PARAMETER | CONDITIONS | | MIN | TYP | MAX | UNITS |
|----------------------------|--|---|-----|-----|-----|-------|
| Supply Voltage | | | 3 | 3.3 | 3.6 | V |
| RFOUT_ Current Consumption | I _{RFOUT_} , minimum output power, single channel | | 9 | | | mA |
| | I _{RFOUT_} , maximum output power, single channel | | 25 | | | |
| Supply Current | Both channels enabled, maximum output power | Total, including RFOUT, both channel (Note 3) | 165 | 200 | | mA |
| | | Each output divide-by-2 | 8 | | | |
| | | I _{CCVCO} + I _{CCRF} (Note 3) | 122 | | | |
| | | Low-power sleep mode | 1 | | | |

AC Electrical Characteristics

(Measured using MAX2871 EV Kit. V_{CC_} = 3V to 3.6V, V_{GND_} = 0V, f_{REF_IN} = 50MHz, f_{PFD} = 25MHz, f_{RFOUT_} = 6000MHz, T_A = -40°C to +85°C. Typical values measured at V_{CC_} = 3.3V, T_A = +25°C, register settings 00780000, 20000141, 01005E42, 00000013, 610F423C, 01400005; unless otherwise noted.) (Note 2)

| PARAMETER | CONDITIONS | MIN | TYP | MAX | UNITS |
|--|-------------------|-----|-----|------------------|------------------|
| REFERENCE OSCILLATOR INPUT (REF_IN) | | | | | |
| REF_IN Input Frequency Range | | 10 | | 210 | MHz |
| REF_IN Input Sensitivity | | 0.7 | | V _{CC_} | V _{P-P} |
| REF_IN Input Capacitance | | | 2 | | pF |
| REF_IN Input Current | | -60 | | +60 | µA |
| PHASE DETECTOR | | | | | |
| Phase Detector Frequency | Integer-N mode | 140 | | | MHz |
| | Fractional-N mode | 125 | | | |

AC Electrical Characteristics (continued)

(Measured using MAX2871 EV Kit. $V_{CC_} = 3V$ to $3.6V$, $V_{GND_} = 0V$, $f_{REF_IN} = 50MHz$, $f_{PFD} = 25MHz$, $f_{RFOUT_} = 6000MHz$, $T_A = -40^{\circ}C$ to $+85^{\circ}C$. Typical values measured at $V_{CC_} = 3.3V$, $T_A = +25^{\circ}C$, register settings 00780000, 20000141, 01005E42, 00000013, 610F423C, 01400005; unless otherwise noted.) (Note 2)

| PARAMETER | CONDITIONS | MIN | TYP | MAX | UNITS |
|--|---|---------------|------|------|------------|
| CHARGE PUMP | | | | | |
| Sink/Source Current | CP[3:0] = 1111, $R_{SET} = 5.1k\Omega$ | | 5.12 | | mA |
| | CP[3:0] = 0000, $R_{SET} = 5.1k\Omega$ | | 0.32 | | |
| R_{SET} Range | | 2.7 | | 10 | k Ω |
| RF OUTPUTS | | | | | |
| Fundamental Frequency Range | | 3000 | | 6000 | MHz |
| Divided Frequency Range | With output dividers (1/2/4/8/16/32/64/128) | 23.4375 | | 6000 | MHz |
| VCO Sensitivity | | | 100 | | MHz/V |
| Frequency Pushing | Open loop | | 0.8 | | MHz/V |
| Frequency Pulling | Open loop into 2:1 VSWR | | 70 | | kHz |
| 2nd Harmonic | Fundamental VCO output | | -40 | | dBc |
| 3rd Harmonic | Fundamental VCO output | | -34 | | dBc |
| 2nd Harmonic | VCO output divided-by-2 | | -25 | | dBc |
| 3rd Harmonic | VCO output divided-by-2 | | -20 | | dBc |
| Maximum Output Power | $f_{RFOUT_} = 3000MHz$ (Note 4) | | 5 | | dBm |
| Minimum Output Power | $f_{RFOUT_} = 3000MHz$ (Note 4) | | -4 | | dBm |
| Output Power Variation (Note 4) | $-40^{\circ}C \leq T_A \leq +85^{\circ}C$ | | 1 | | dB |
| | $3V \leq V_{CC_} \leq 3.6V$ | | 0.2 | | |
| Muted Output Power | (Note 4) | | -40 | | dBm |
| VCO AND FREQUENCY SYNTHESIZER NOISE | | | | | |
| VCO Phase Noise (Note 5) | VCO at 3000MHz | 10kHz offset | | -83 | dBc/Hz |
| | | 100kHz offset | | -111 | |
| | | 1MHz offset | | -136 | |
| | | 5MHz offset | | -149 | |
| | VCO at 4500MHz | 10kHz offset | | -77 | |
| | | 100kHz offset | | -106 | |
| | | 1MHz offset | | -132 | |
| | | 5MHz offset | | -147 | |
| | VCO at 6000MHz | 10kHz offset | | -71 | |
| | | 100kHz offset | | -101 | |
| | | 1MHz offset | | -128 | |
| | | 5MHz offset | | -144 | |
| In-Band Noise Floor | Normalized (Note 6) | | -229 | | dBc/Hz |
| 1/f Noise | Normalized (Note 7) | | -122 | | dBc/Hz |
| In-Band Phase Noise | (Note 8) | | -102 | | dBc/Hz |
| Integrated RMS Jitter | (Note 9) | | 0.2 | | ps |

AC Electrical Characteristics (continued)

(Measured using MAX2871 EV Kit. $V_{CC_}$ = 3V to 3.6V, $V_{GND_}$ = 0V, f_{REF_IN} = 50MHz, f_{PFD} = 25MHz, $f_{RFOUT_}$ = 6000MHz, T_A = -40°C to +85°C. Typical values measured at $V_{CC_}$ = 3.3V, T_A = +25°C, register settings 00780000, 20000141, 01005E42, 00000013, 610F423C, 01400005; unless otherwise noted.) (Note 2)

| PARAMETER | CONDITIONS | MIN | TYP | MAX | UNITS |
|---------------------------------------|----------------------|-----|-----|---------------------|-------|
| Spurious Signals Due to PFD Frequency | 50kHz loop bandwidth | | -88 | | dBc |
| VCO Tune Voltage | | 0.5 | | $V_{CC_}$ - 0.5 | V |
| TEMPERATURE SENSOR AND ADC | | | | | |
| ADC Resolution | | | 7 | | Bits |
| Temperature Sensor Accuracy | | | 3 | | °C |

DIGITAL I/O CHARACTERISTICS

($V_{CC_}$ = +3V to +3.6V, $V_{GND_}$ = 0V, T_A = -40°C to +85°C. Typical values at $V_{CC_}$ = 3.3V, T_A = +25°C.) (Note 2)

| PARAMETER | CONDITIONS | MIN | TYP | MAX | UNITS |
|--|----------------------|---------------------|-----|-----|-------|
| SERIAL INTERFACE INPUTS (CLK, DATA, LE, CE, RFOUT_EN) | | | | | |
| Input Logic-Level Low | V_{IL} | | 0.4 | | V |
| Input Logic-Level High | V_{IH} | | 1.5 | | V |
| Input Current | I_{IH}/I_{IL} | -1 | | +1 | μA |
| Input Capacitance | | | 1 | | pF |
| SERIAL INTERFACE OUTPUTS (MUX, LD) | | | | | |
| Output Logic-Level Low | 0.3mA sink current | | | 0.4 | V |
| Output Logic-Level High | 0.3mA source current | $V_{CC_}$ - 0.4 | | | V |
| Output Current Level High | | | 0.5 | | mA |

SPI TIMING CHARACTERISTICS(V_{CC_} = +3V to +3.6V, V_{GND_} = 0V, T_A = -40°C to +85°C. Typical values at V_{CC_} = 3.3V, T_A = +25°C.) (Note 2)

| PARAMETER | SYMBOL | CONDITIONS | MIN | TYP | MAX | UNITS |
|-----------------------------|------------------|--|-----|-----|-----|-------|
| CLK Clock Period | t _{CP} | Guaranteed by SCL pulse-width low and high | 50 | | | ns |
| CLK Pulse-Width Low | t _{CL} | | 25 | | | ns |
| CLK Pulse-Width High | t _{CH} | | 25 | | | ns |
| LE Setup Time | t _{LES} | | 20 | | | ns |
| LE Hold Time | t _{LEH} | | 10 | | | ns |
| LE Minimum Pulse-Width High | t _{LEW} | | 20 | | | ns |
| Data Setup Time | t _{DS} | | 25 | | | ns |
| Data Hold Time | t _{DH} | | 25 | | | ns |
| MUX Valid | t _{DOT} | MUX transition valid after CLK fall | | | 10 | ns |

Note 2: Production tested at T_A = +25°C. Cold and hot are guaranteed by design and characterization.**Note 3:** f_{REFIN} = 100MHz, phase detector frequency = 25MHz, RF output = 6000MHz.

Register setting: 00780000, 00400061, 34011242, F8010003, 638FF1FC, 80400005.

Note 4: Measured single ended with 27nH to V_{CC_RF} into 50Ω load. Power measured with single output enabled. Unused output has 27nH to V_{CC_RF} with 50Ω termination.**Note 5:** VCO phase noise is measured open loop.**Note 6:** Measured at 200kHz using a 50MHz Billee NV108C19554 OCVCXO with 2MHz loop bandwidth. Register setting 801E0000, 8000FFF9, 80005FC2, 6C10000B, 638E80FC, 400005. EV kit loop filter: C2 = 1500pF, C1 = 33pF, R2A = 0Ω, R2B = 1100Ω, R3 = 0Ω, C3 = open.**Note 7:** 1/f noise contribution to the in-band phase noise is computed by using 1/fnoise + 10log(10kHz/f_{OFFSET}) + 20log(f_{RF}/1GHz). Register setting: 803A0000, 8000FFF9, 81005F42, F4000013, 6384803C, 001500005.**Note 8:** f_{REFIN} = 50MHz; f_{PFD} = 25MHz; offset frequency = 10kHz; VCO frequency = 4227MHz, output divide-by-2 enabled. RFOUT = 2113.5MHz; N = 169; loop BW = 40kHz, CP[3:0] = 1111; integer mode.**Note 9:** f_{REFIN} = 50MHz; f_{PFD} = 50MHz; VCO frequency = 4400MHz, f_{RFOUT} = 4400MHz; loop BW = 65kHz. Register setting: 002C0000, 200303E9, 80005642, 00000133, 638E82FC, 01400005. EV kit loop filter: C2 = 0.1μF, C1 = 0.012μF, R2A = 0Ω, R2B = 120Ω, R3 = 250Ω, C3 = 820pF.

Typical Operating Characteristics

(Measured with MAX2871 EV Kit. $V_{CC_} = 3.3V$, $V_{GND_} = 0V$, $f_{REF_IN} = 50MHz$, $T_A = +25^\circ C$, see the [Testing Conditions](#) Table.)

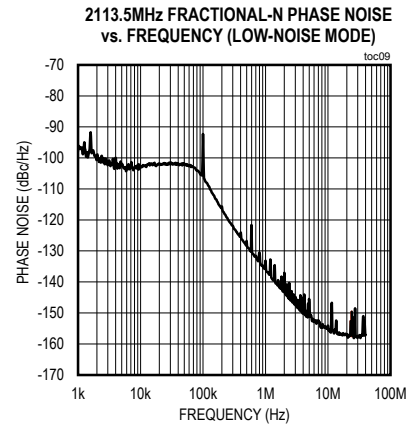
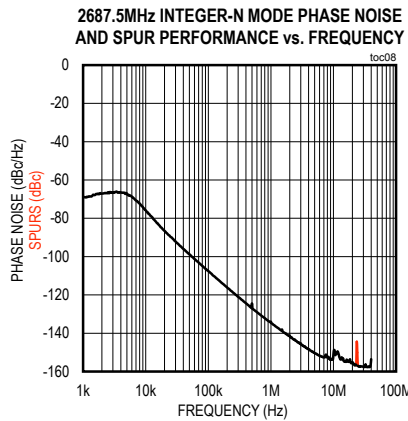
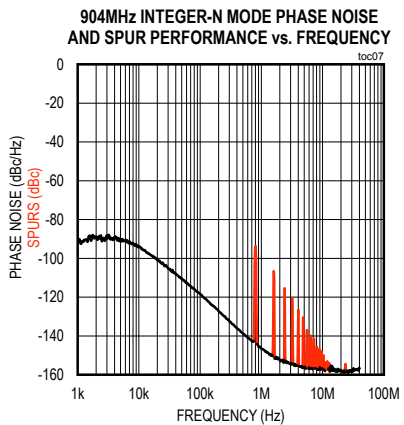
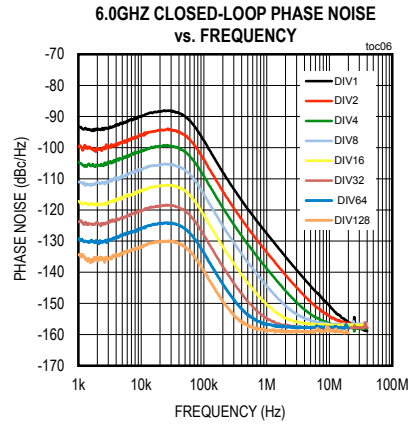
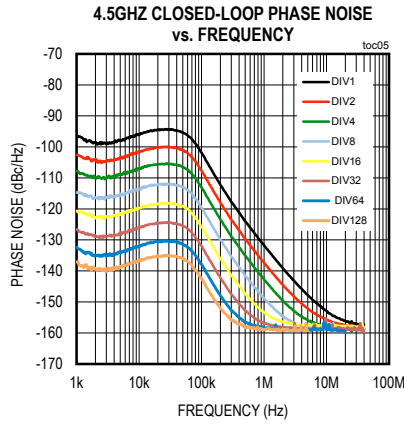
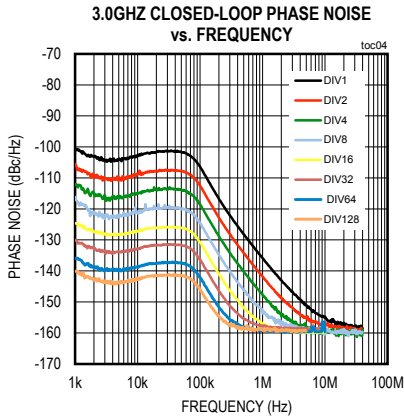
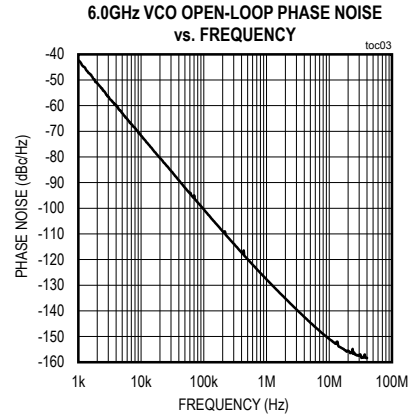
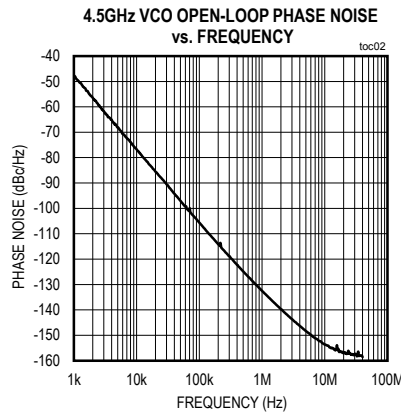
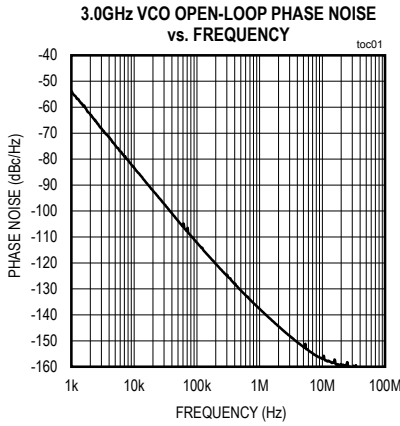

Typical Operating Characteristics (continued)

(Measured with MAX2871 EV Kit. $V_{CC_} = 3.3V$, $V_{GND_} = 0V$, $f_{REF_IN} = 50MHz$, $T_A = +25^{\circ}C$, see the [Testing Conditions](#) Table.)

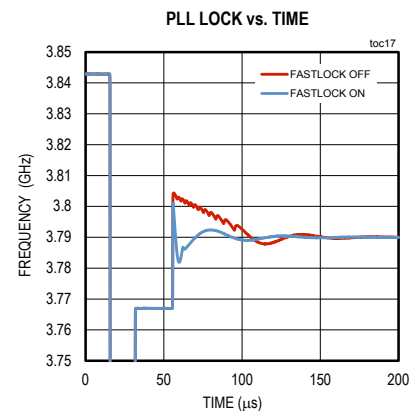
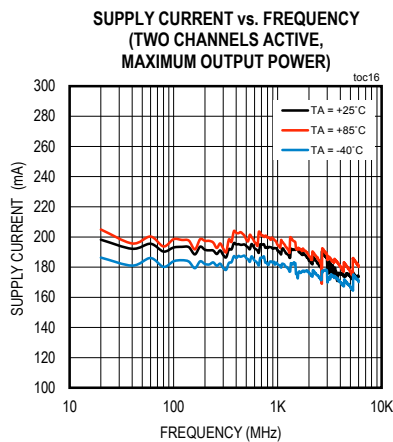
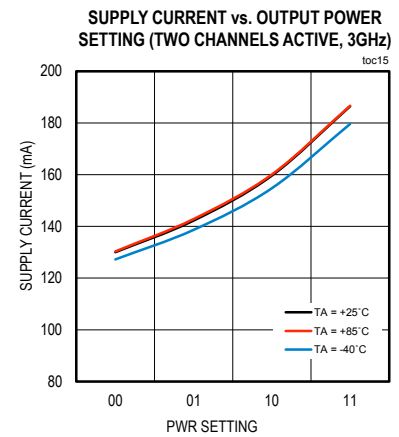
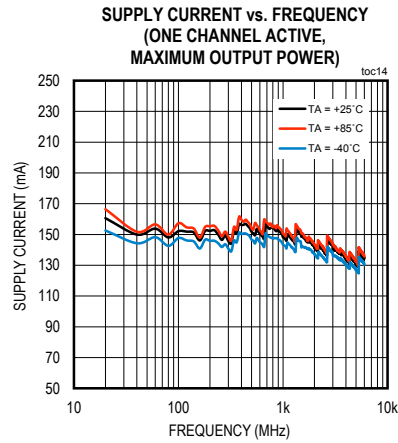
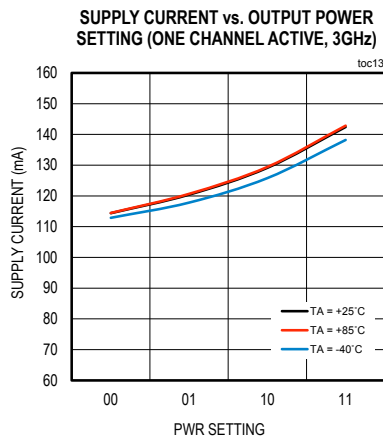
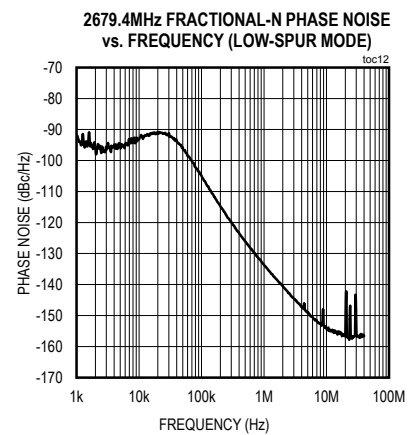
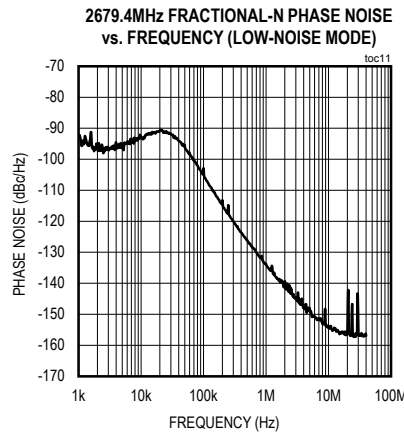
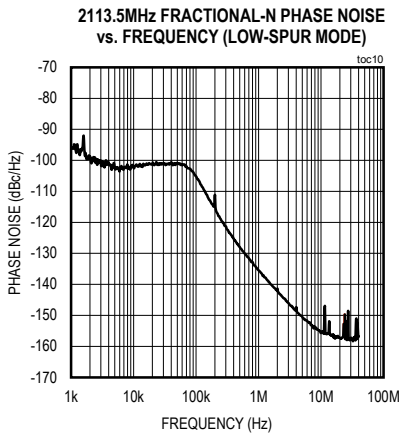

Typical Operating Characteristics Testing Conditions Table

| TOC TITLE | f _{REF} (MHz) | f _{PDF} (MHz) | REGISTER SETTINGS (hex) | LOOP FILTER BW (Hz) | MAX2871 EV KIT COMPONENT VALUES | | | | | COMMENTS |
|---|---------------------------|---------------------------|---|---------------------------|---------------------------------|------------------|-----------|-----------|-----------|---|
| | | | | | C2 (F) | R2A + R2B (Ω) | C1 (F) | R3 (Ω) | C3 (F) | |
| 3.0GHz VCO OPEN-LOOP PHASE NOISE vs. FREQUENCY | N/A | N/A | 80B40000, 80000141, 0000405A, XX00013, 648020FC, 00000005 | N/A | N/A | N/A | N/A | N/A | N/A | VCO bits set for 3GHz output, VAS_SHDN = 1 |
| 4.5GHz VCO OPEN-LOOP PHASE NOISE vs. FREQUENCY | N/A | N/A | 80B40000, 80000141, 0000405A, XX00013, 648020FC, 00000005 | N/A | N/A | N/A | N/A | N/A | N/A | VCO bits set for 4.5GHz output, VAS_SHDN = 1 |
| 6.0GHz VCO OPEN-LOOP PHASE NOISE vs. FREQUENCY | N/A | N/A | 80B40000, 80000141, 0000405A, XX00013, 648020FC, 00000005 | N/A | N/A | N/A | N/A | N/A | N/A | VCO bits set for 6.0GHz output, VAS_SHDN = 1 |
| 3.0GHz CLOSED-LOOP PHASE NOISE vs. FREQUENCY | 50 | 25 | 803C0000 80000141 00009E42, E8000013, 618160FC, 00400005 | 40k | 0.1μ | 120 | 0.012μ | 250 | 820p | |
| 4.5GHz CLOSED-LOOP PHASE NOISE vs. FREQUENCY | 50 | 25 | 805A0000, 80000141, 00009E42, E8000013, 618160FC, 00400005 | 40k | 0.1μ | 120 | 0.012μ | 250 | 820p | |
| 6.0GHz CLOSED-LOOP PHASE NOISE vs. FREQUENCY | 50 | 25 | 80780000, 80000141, 00009E42, EA000013, 608C80FC, 00400005 | 40k | 0.1μ | 120 | 0.012μ | 250 | 820p | |

Typical Operating Characteristics Testing Conditions Table (continued)

| TOC TITLE | f _{REF} (MHz) | f _{PDF} (MHz) | REGISTER SETTINGS (hex) | LOOP FILTER BW (Hz) | MAX2871 EV KIT COMPONENT VALUES | | | | | COMMENTS |
|--|------------------------|------------------------|---|---------------------|---------------------------------|---------------|--------|--------|--------|--------------------------|
| | | | | | C2 (F) | R2A + R2B (Ω) | C1 (F) | R3 (Ω) | C3 (F) | |
| 904MHz INTEGER-N MODE PHASE NOISE AND SPUR PERFORMANCE vs. FREQUENCY | 40 | 0.8 | 82350000, 800007D1, E1065FC2, 2C000013, 6020803C, 00400005 | 16k | 0.1μ | 806 | 3300p | 1201 | 470p | |
| 2687.5MHz INTEGER-N PHASE NOISE AND SPUR PERFORMANCE vs. FREQUENCY | 40 | 0.5 | 94FF0000, 803207D1, 010A1E42, B00000A3, 6090803C, 00400005 | 5k | 0.1μ | 1000 | 6800p | 300 | 0.01μ | |
| 2113.5MHz FRACTIONAL-N PHASE NOISE (LOW-NOISE MODE) vs. FREQUENCY | 50 | 25 | 00548050, 400003E9, 81005FC2, E8000013, 609C80FC, 00400005 | 40k | 0.1μ | 120 | 0.012μ | 250 | 820p | |
| 2113.5MHz FRACTIONAL-N PHASE NOISE vs. FREQUENCY (LOW-SPUR MODE) | 50 | 25 | 00548050, 400003E9, E1005FC2, E8000013, 609C80FC, 00400005 | 40k | 0.1μ | 120 | 0.012μ | 250 | 820p | |
| 2679.4MHz FRACTIONAL-N PHASE NOISE vs. FREQUENCY (LOW-NOISE MODE) | 50 | 25 | 00358160, 203207D1, 01005E42, B20000A3, 6010003C, 00400005 | 40k | 0.1μ | 120 | 0.012μ | 250 | 820p | |
| 2679.4MHz FRACTIONAL-N PHASE NOISE vs. FREQUENCY (LOW-SPUR MODE) | 50 | 25 | 00358160, 203207D1, 41005E42, B20000A3, 6010003C, 00400005 | 40k | 0.1μ | 120 | 0.012μ | 250 | 820p | |
| SUPPLY CURRENT vs. OUTPUT POWER SETTING (ONE CHANNEL ACTIVE, 3GHz) | 50 | 25 | 003C0000, 20000321, 01005E42, 00000013, 610F423C, 01400005, | | | | | | | APWR swept from 00 to 11 |

Typical Operating Characteristics Testing Conditions Table (continued)

| TOC TITLE | f _{REF} (MHz) | f _{PFD} (MHz) | REGISTER SETTINGS (hex) | LOOP FILTER BW (Hz) | MAX2871 EV KIT COMPONENT VALUES | | | | | COMMENTS |
|---|---------------------------|---------------------------|---|---------------------------|---------------------------------|------------------|-----------|-----------|-----------|---|
| | | | | | C2 (F) | R2A + R2B (Ω) | C1 (F) | R3 (Ω) | C3 (F) | |
| SUPPLY CURRENT vs. FREQUENCY (ONE CHANNEL ACTIVE, MAXIMUM OUTPUT POWER) | 50 | 25 | 003C0000, 20000321, 01005E42, 00000013, 610F423C, 01400005 | | | | | | | N and F values changed for each frequency |
| SUPPLY CURRENT vs. OUTPUT POWER SETTING (TWO CHANNELS ACTIVE) | 50 | 25 | 003C0000, 20000321, 01005E42, 00000013, 610F43FC, 01400005 | | | | | | | APWR and BPWR swept from 00 to 11 |
| SUPPLY CURRENT vs. FREQUENCY (TWO CHANNELS ACTIVE MAXIMUM OUTPUT POWER) | 50 | 25 | 003C0000, 20000321, 01005E42, 00000013, 610F43FC, 01400005 | | | | | | | N and F values swept for each frequency |
| PLL LOCK vs. TIME | 40 | 40 | 00250120, 20320141, 00004042, 000000A3, 0184023C, 01400005 | 40k | 0.1μ | 120 | 0.012μ | 250 | 820p | CDM changed from 00 to 01 |

Pin Configuration

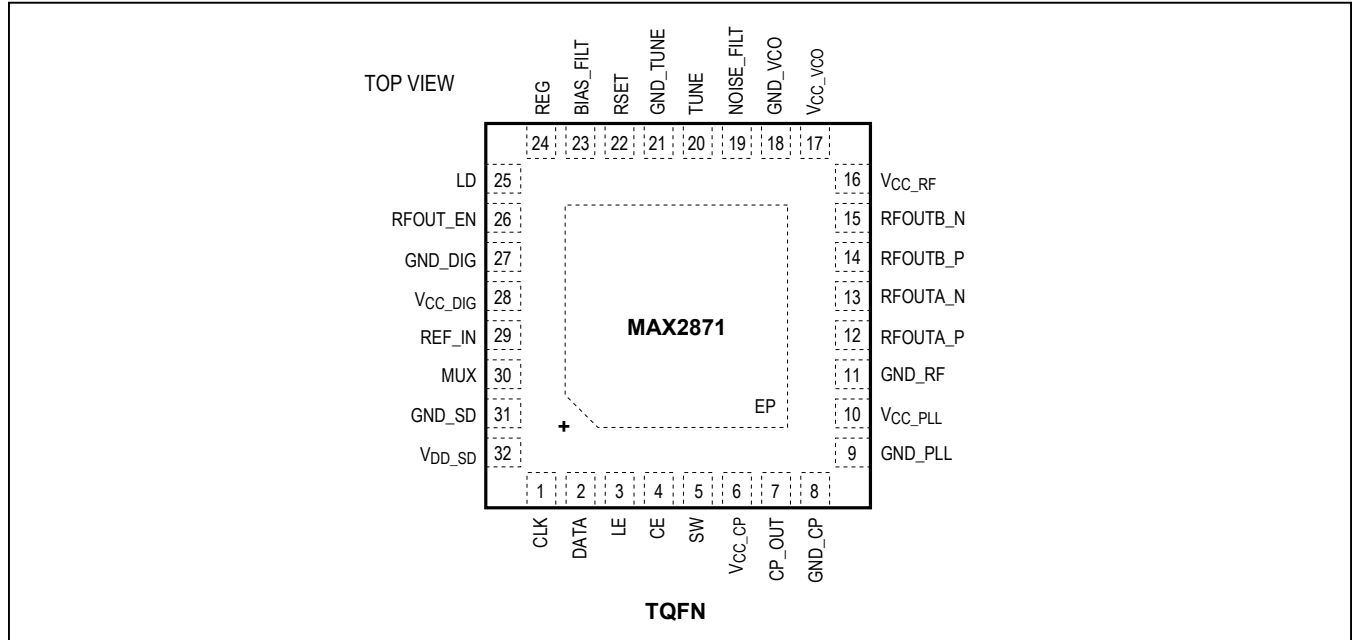

Pin Description

| PIN | NAME | FUNCTION |
|-----|---------------------|--|
| 1 | CLK | Serial Clock Input. The data is latched into the 32-bit shift register on the rising edge of the CLK line. |
| 2 | DATA | Serial Data Input. The serial data is loaded MSB first. The 3 LSBs identify the register address. |
| 3 | LE | Load Enable Input. When LE goes high the data stored in the shift register is loaded into the appropriate latches. |
| 4 | CE | Chip Enable. A logic-low powers the part down and the charge pump becomes high impedance. |
| 5 | SW | Fast-Lock Switch. Connect to the loop filter when using the fast-lock mode. |
| 6 | V _{CC_CP} | Power Supply for Charge Pump. Place decoupling capacitors as close as possible to the pin. |
| 7 | CP_OUT | Charge-Pump Output. Connect to external loop filter input. |
| 8 | GND_CP | Ground for Charge-Pump. Connect to board ground, not to the paddle. |
| 9 | GND_PLL | Ground for PLL. Connect to main board ground plane, not to the paddle. |
| 10 | V _{CC_PLL} | Power Supply for PLL. Place decoupling capacitors as close as possible to the pin. |
| 11 | GND_RF | Ground for RF Outputs. Connect to board ground plane, not to the paddle. |
| 12 | RFOUTA_P | Open Collector Positive RF Output A. See RFOUT± and RFOUTB± section in Detailed Description . |
| 13 | RFOUTA_N | Open Collector Negative RF Output A. See RFOUT± and RFOUTB± section in Detailed Description . |

Pin Description (continued)

| PIN | NAME | FUNCTION |
|-----|---------------------|---|
| 14 | RFOUTB_P | Open Collector Positive RF Output B. See RFOUT± and RFOUTB± section in Detailed Description . |
| 15 | RFOUTB_N | Open Collector Negative RF Output B. See RFOUT± and RFOUTB± section in Detailed Description . |
| 16 | V _{CC_RF} | Power Supply for RF Output and Dividers. Place decoupling capacitors as close as possible to the pin. |
| 17 | V _{CC_VCO} | VCO Power Supply. Place decoupling capacitors to the analog ground plane. |
| 18 | GND_VCO | Ground for VCO. Connect to main board ground plane, not directly to the paddle. |
| 19 | NOISE_FILT | VCO Noise Decoupling. Place a 1µF capacitor to ground. |
| 20 | TUNE | Control Input to the VCO. Connect to external loop filter. |
| 21 | GND_TUNE | Ground for Control Input to the VCO. Connect to main board ground plane, not directly to the paddle. |
| 22 | RSET | Charge-Pump Current Range Input. Connect an external resistor to ground to set the minimum CP current. $I_{CP} = 1.63/R_{SET} \times (1 + CP)$ |
| 23 | BIAS_FILT | VCO Noise Decoupling. Place a 1µF capacitor to ground. |
| 24 | REG | Reference Voltage Compensation. Place a 1µF capacitor to ground. |
| 25 | LD | Lock Detect Output. Logic-high when locked, and logic-low when unlocked. See register description for more details (Table 9). |
| 26 | RFOUT_EN | RF Output Enable. A logic-low disables the RF outputs. |
| 27 | GND_DIG | Ground for Digital Circuitry. Connect to main board ground plane, not directly to the paddle. |
| 28 | V _{CC_DIG} | Power Supply for Digital Circuitry. Place decoupling capacitors as close as possible to pin. |
| 29 | REF_IN | Reference Frequency Input. This is a high-impedance input with a nominal bias voltage of $V_{CC_DIG}/2$. AC-couple to reference signal. |
| 30 | MUX | Multiplexed I/Os. See Table 5 . |
| 31 | GND_SD | Ground for Sigma-Delta Modulator. Connect to main board ground plane, not directly to the paddle. |
| 32 | V _{CC_SD} | Power Supply for Sigma-Delta Modulator. Place decoupling capacitors as close as possible to the pin. |
| — | EP | Exposed Pad. Connect to board ground. |

Detailed Description

4-Wire Serial Interface

The MAX2871 serial interface contains six write-only and one read-only 32-bit registers. The 29 most-significant bits (MSBs) are data, and the three least-significant bits (LSBs) are the register address. Register data is loaded MSB first through the 4-wire serial interface (SPI). When LE is logic-low, the logic level at DATA is shifted at the rising edge of CLK. At the rising edge of LE, the 29 data bits are latched into the register selected by the address bits. The user must program all register values after power-up.

Register programming order should be address 0x05, 0x04, 0x03, 0x02, 0x01, and 0x00. Several bits are double buffered to update the settings at the same time. See the register descriptions for double buffered settings.

Register 0x06 can be read back through the MUX pin. The user must set MUX (register 5, bit 18 and register 2, bits 28:26) = 1100. To begin the read sequence, set LE to logic-low, send 32 periods of CLK, and set LE to logic-high. While the CLK is running, the DATA pin can be held at logic-high or logic-low for 29 clocks, but the last 3 bits must be 110 to indicate register 6, then set LE back to logic-high after the 32nd clock. Finally, send 1 period of the clock. The MSB of register 0x06 appears on the falling edge of the next clock and continues to shift out for the next 29 clock cycles (Figure 2). After the LSB of register 0x06 has been read, the user can reset MUX register = 0000.

Power Modes

The MAX2871 can be put into low-power mode by setting SHDN = 1 (register 2, bit 5) or by setting the CE pin to logic-low.

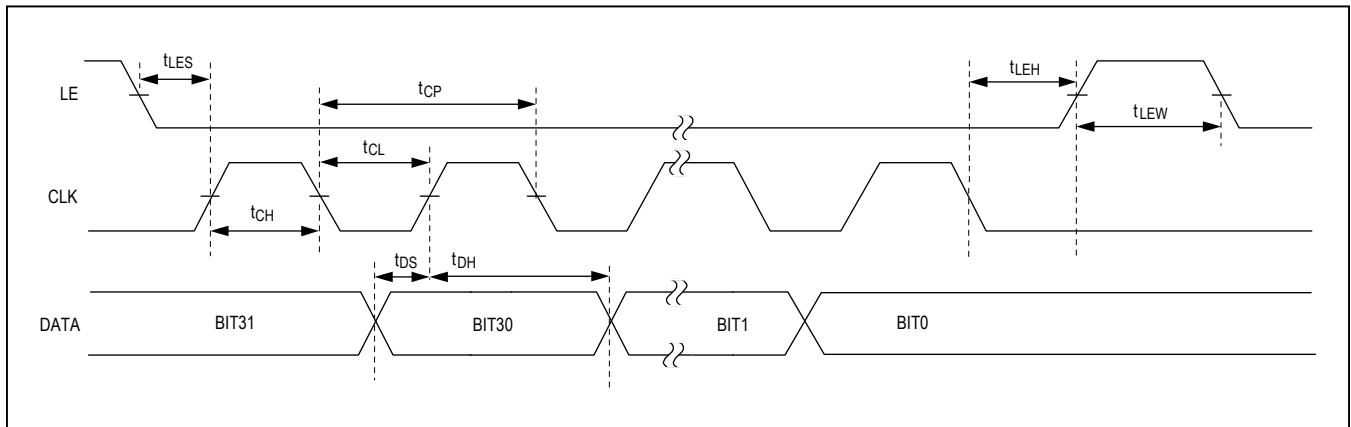

Figure 1. SPI Timing Diagram

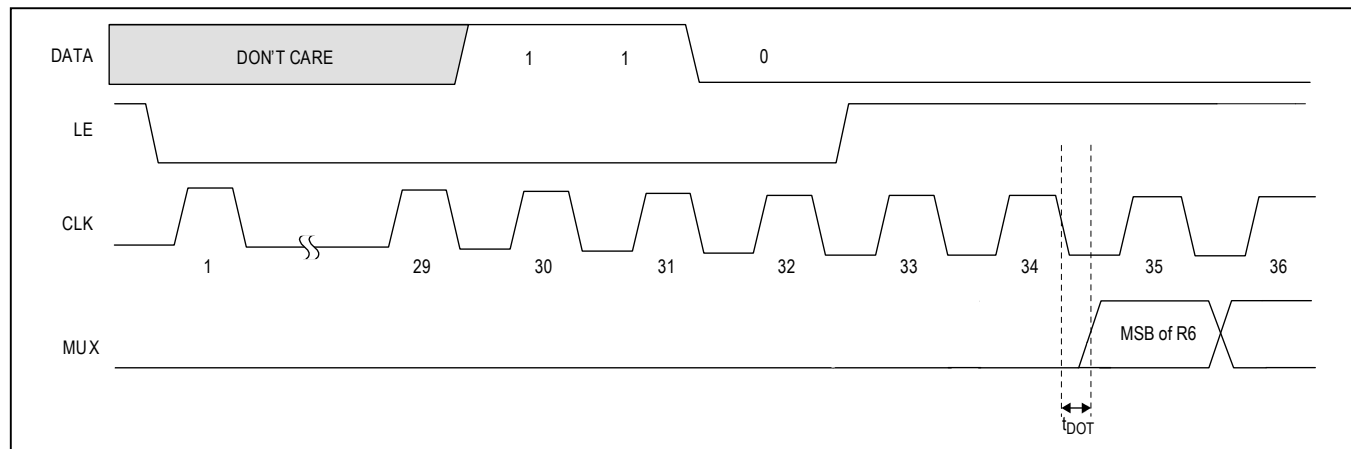

Figure 2. Initiating Readback

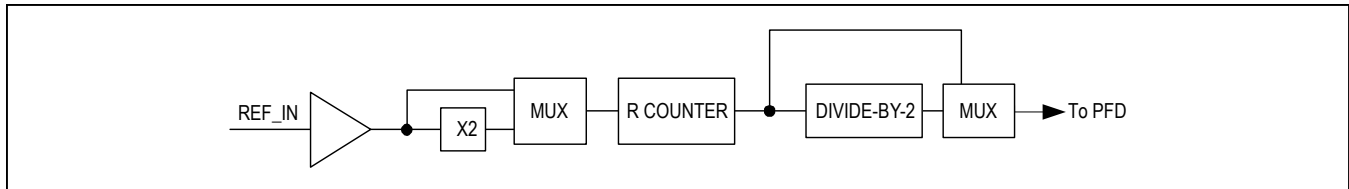

Figure 3. Reference Input

After exiting low-power mode, allow at least 20ms for external capacitors to charge to their final values before programming the final VCO frequency.

Reference Input

The reference input stage is configured as a CMOS inverter with shunt resistance from input to output. In shut-down mode this input is set to high impedance to prevent loading of the reference source.

The reference input signal path also includes optional x2 and ÷2 blocks. When the reference doubler is enabled (DBR = 1), the maximum reference input frequency is limited to 105MHz. When the doubler is disabled, the reference input frequency is limited to 210MHz. The minimum reference frequency is 10MHz. The minimum R counter divide ratio is 1, and the maximum divide ratio is 1023.

Int, Frac, Mod and R Counter Relationship

The phase-detector frequency is determined as follows:

$$f_{\text{PFD}} = f_{\text{REF}} \times [(1 + \text{DBR}) / (\text{R} \times (1 + \text{RDIV2}))]$$

f_{REF} represents the external reference input frequency. DBR (register 2, bit 25) sets the f_{REF} input frequency doubler mode (0 or 1). RDIV2 (register 2, bit 24) sets the f_{REF} divide-by-2 mode (0 or 1). R (register 2, bits 23:14) is the value of the 10-bit programmable reference counter (1 to 1023). The maximum f_{PFD} is 125MHz for frac-N mode and 140MHz for int-N mode. The R-divider can be held in reset when RST (register 2, bit 3) = 1.

The VCO frequency (f_{VCO}), N, F, and M can be determined based on desired RF output frequency (f_{RFOUTA}) as follows:

Set DIVA value property based on f_{RFOUTA} and [Table 4](#) (register 4, bits 22:20)

$$f_{\text{VCO}} = f_{\text{RFOUTA}} \times \text{DIVA}$$

If bit FB = 1, (DIVA is not in PLL feedback loop):

$$N + (F/M) = f_{\text{VCO}} / f_{\text{PFD}}$$

If bit FB = 0, (DIVA is in PLL feedback loop) and DIVA ≤ 16:

$$N + (F/M) = (f_{\text{VCO}} / f_{\text{PFD}}) / \text{DIVA}$$

If bit FB = 0, (DIVA is in PLL feedback loop) and DIVA > 16:

$$N + (F/M) = (f_{\text{VCO}} / f_{\text{PFD}}) / 16$$

N is the value of the 16-bit N counter (16 to 65535), programmable through bits 30:15 of register 0. M is the fractional modulus value (2 to 4095), programmable through bits 14:3 of register 1. F is the fractional division value (0 to MOD - 1), programmable through bits 14:3 of register 0. In frac-N mode, the minimum N value is 19 and maximum N value is 4091. The N counter is held in reset when RST = 1 (register 2, bit 3). DIVA is the RF output divider setting (0 to 7), programmable through bits 22:20 of register 4. The division ratio is set by 2^{DIVA} .

The RF B output frequency is determined as follows:

$$\text{If BDIV} = 0 \text{ (register 4, bit 9), } f_{\text{RFOUTB}} = f_{\text{RFOUTA}}$$

$$\text{If BDIV} = 1, f_{\text{RFOUTB}} = f_{\text{VCO}}$$

Int-N/Frac-N Modes

Integer-N mode is selected by setting bit INT = 1 (register 0, bit 31). When operating in integer-N mode, it is also necessary to set bit LDF (register 2, bit 8) to set the lock detect to integer-N mode.

The device's frac-N mode is selected by setting bit INT = 0 (register 0, bit 31). Additionally, set bit LDF = 0 (register 2, bit 8) for frac-N lock-detect mode.

If the device is in frac-N mode, it will remain in frac-N mode when fractional division value F = 0, which can result in unwanted spurs. To avoid this condition, the device can automatically switch to integer-N mode when F = 0 if the bit F01 = 1 (register 5, bit 24).

Phase Detector and Charge Pump

The device's charge-pump current is determined by the value of the resistor from pin RSET to ground and the value of bits CP (register 2, bits 12:9) as follows:

$$I_{\text{CP}} = 1.63 / R_{\text{SET}} \times (1 + \text{CP} < 3:0 >)$$

To reduce spurious in frac-N mode, set charge-pump linearity bits CPL = 00/01/10/11 (register 1, bits 30:29). The user can determine which mode works best for their application. For int-N mode, set CPL = 00.

The charge-pump output can be put into high-impedance mode when TRI = 1 (register 2, bit 4). The output is in normal mode when TRI = 0.

The phase detector polarity can be changed if an active inverting loop filter topology is used. For noninverting loop filters, set PDP = 1 (register 2, bit 6). For inverting loop filters, set PDP = 0.

MUX

MUX is a multipurpose input/output for observing and controlling various internal functions of the MAX2871. MUX can also be configured as serial data output. Bits MUX (register 5, bit 18 and register 2, bit 28:26) are used to select the desired MUX function (see Table 5).

Lock Detect

Lock detect can be monitored through the LD output by setting the LD bits (register 5, bits 23:22). For digital lock detect, set LD = 01. The digital lock detect is dependent on the mode of the synthesizer. In frac-N mode set LDF = 0, and in int-N mode set LDF = 1. To set the accuracy of the digital lock detect, see Table 1 and Table 2.

Analog lock detect can be set with LD = 10. In this mode, LD is an open-drain output and requires an external pullup resistor.

The lock detect output validity is dependent on many factors. The lock detect output is not valid during VCO auto selection process. After the VCO auto selection process has completed, the lock detect output is not valid until the TUNE voltage has settled. TUNE voltage settling time is dependent on loop filter bandwidth, and can be calculated using EE-Sim Simulation tool found at www.maximintegrated.com.

Cycle Slip Reduction

Cycle slip reduction is one of the two methods available to improve lock time. It is enabled by setting CSM bit (register 3, bit 18) to 1. In this mode, the charge pump must be set to its minimum value.

Fast-Lock

Another method to decrease lock time is to use a fast-lock mode. This mode requires that CP = 0000 (register 2, bits 12:9) and that the shunt resistive portion of the loop filter be segmented into two parts, where one resistor is 1/4 of the total resistance, and the other resistor is 3/4 of the

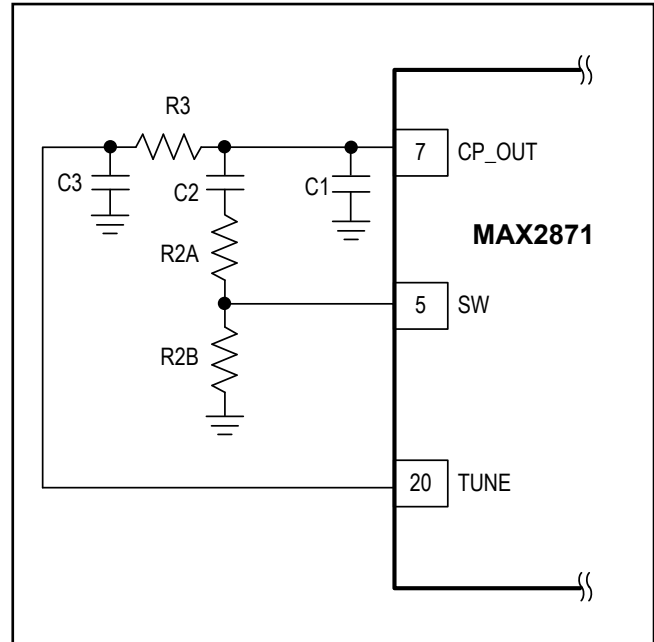

Figure 4. Fast Lock Filter Topology

Table 1. Frac-N Digital Lock-Detect Settings

| PFD FREQUENCY | LDS | LDP | LOCKED UP/DOWN TIME SKEW (ns) | NUMBER OF LOCKED CYCLES TO SET LD | UP/DOWNTIME SKEW TO UNSET LD (ns) |
|---------------|-----|-----|-------------------------------|-----------------------------------|-----------------------------------|
| ≤ 32MHz | 0 | 0 | 10 | 40 | 15 |
| ≤ 32MHz | 0 | 1 | 6 | 40 | 15 |
| > 32MHz | 1 | X | 4 | 40 | 4 |

Table 2. Int-N Digital Lock-Detect Settings

| PFD FREQUENCY | LDS | LDP | LOCKED UP/DOWN TIME SKEW (ns) | NUMBER OF LOCKED CYCLES TO SET LD | UP/DOWNTIME SKEW TO UNSET LD (ns) |
|---------------|-----|-----|-------------------------------|-----------------------------------|-----------------------------------|
| ≤ 32MHz | 0 | 0 | 10 | 5 | 15 |
| ≤ 32MHz | 0 | 1 | 6 | 5 | 15 |
| > 32MHz | 1 | X | 4 | 5 | 4 |

total resistance. The larger resistor should be connected from ground to SW, and the smaller resistor from SW to the loop filter capacitor (see [Figure 4](#)). When CDM = 01 (register 3, bits 16:15), fast-lock is active after the VAS has completed. During fast-lock, the charge pump is increased to CP = 1111 and the shunt loop filter resistance is set to 1/4 of the total resistance by changing pin SW from high impedance to ground. Fast-lock deactivates after a timeout set by the user. This timeout is loop filter dependent, and is set by:

$$t_{\text{FAST-LOCK}} = M \times \text{CDIV} / f_{\text{PFD}}$$

where M is the modulus setting and CDIV is the clock divider setting. The user must determine the CDIV setting based on their loop filter time constant.

RFOUTA± and RFOUTB±

The device has dual differential open-collector RF outputs that require an external RF choke or a 50Ω resistor to supply for each output. Each differential output can be independently enabled or disabled by setting bits RFA_EN (register 4, bit 5) and RFB_EN (register 4, bit 8). Both outputs are also controlled by applying a logic-high (enabled) or logic-low (disabled) to pin RFOUT_EN.

The output power of each output can be individually controlled with APWR (register 4, bits 4:3) for RFOUTA and BPWR (register 4, bits 7:6) for RFOUTB. The available differential output power settings are from -4dBm to +5dBm, in 3dB steps with 50Ω pullup to supply. The available single-ended output power ranges from -4dBm to +5dBm in 3dB steps with a RF choke to supply. Across the entire frequency range different pullup elements (L or R) are required for optimal output power. If single-ended output is used, the unused output should be supplied and terminated in the same manner as the corresponding load. If a differential output is unused then those RFOUT pins should be directly connected to VCC_RF (pin 16).

To prevent undesired frequencies from being output while acquiring lock, the output power can be disabled when the PLL is unlocked by using MTLN (register 4, bit 10). A logic 1 will disable the outputs when the digital lock detect is logic low. When acquiring lock the output can overshoot and pass through the desired frequency. In some circumstances, the digital lock detect will flicker high during these periods. To prevent this from happening, a timer can be used to delay the output from enabling after losing lock. Enable MUTEDL (register 3, bit 17) with MTLN enabled to use this function. The delay for enabling the output is set by:

$$\text{Delay} = \text{CDIV} \times M / f_{\text{PFD}}$$

where CDIV (register 3, bits 14:3) is the clock divider, M (register 1, bits 14:3) is the variable modulus for the fractional N modulator, and f_{PFD} is the phase detector frequency.

Voltage-Controlled Oscillator

The fundamental VCO frequency of the device guarantees gap-free coverage from 3.0GHz to 6.0GHz using four individual VCO core blocks with 16 sub-bands within each block. Connect the output of the loop filter to the TUNE input. The TUNE input is used to control the VCO.

Tune ADC

A 7-bit ADC is used to read back the VCO tuning voltage. The ADC value can be read back through register 6, bits 22:16. To digitize the tuning voltage, do the following:

- 1) Set bits CDIV (register 3, bits 14:3) = $f_{\text{PFD}}/100\text{kHz}$ to set the clock speed for the ADC.
- 2) Set bits ADCM (register 5, bits 5:3) = 100 to enable the ADC to read the TUNE pin voltage.
- 3) Set bit ADCS (register 5, bit 6) = 1 to start the ADC conversion process.
- 4) Wait 100μs for the conversion process to finalize.
- 5) Read back register 6. The ADC value is located in bits 22:16.
- 6) Reset bits ADCM = 0 and ADCS = 0.

The voltage on the TUNE pin can be calculated as:

$$V = 0.315 + \text{ADC} \times 0.0165$$

VCO Autoselect (VAS) State Machine

An internal VCO autoselect state machine is initiated when register 0 is programmed to automatically select the correct VCO if bit VAS_SHDN = 0 (register 3, bit 25). If VAS_SHDN = 1, then the VCO can be manually selected by bits VCO (register 3, bits 31:26).

The state machine clock, f_{BS} , must be set to 50kHz. This is set by the BS bits (register 4, bits 25:24, 19:12). The formula for setting BS is:

$$\text{BS} = f_{\text{PFD}} / 50\text{kHz}$$

where f_{PFD} is the phase-detector frequency. The BS value should be rounded to the nearest integer. If the calculated BS is higher than 1023, then set BS = 1023. If f_{PFD} is lower than 50kHz, then set BS = 1. The time needed to select the correct VCO is $10/f_{\text{BS}}$.

The VAS_TEMP bit (register 3, bit 24) can be used to select the best VCO for the given ambient temperature to ensure that the VCO will not drift out of lock if the tem-

perature changes within -40°C to $+85^{\circ}\text{C}$. Bits RFA_EN (register 4, bit 5) and RFB_EN (register 4, bit 8) must be 0, and bits 30:29 of register 5 must be set to 11 during VCO acquisition. Setting VAS_TEMP = 1 will increase the time needed to achieve lock from $10/f_{\text{BS}}$ to approximately 100ms.

Phase Adjustment

After achieving lock, the phase of the RF output can be changed in increments of P (register 1, bits 26:15) /M (register 1, bits 14:3) $\times 360^{\circ}$.

For proper phase adjustment, the following register guidelines must be used:

- INT (register 0, bit 31) = 0
- N (register 0, bits 30:15) ≤ 19 and ≥ 4091
- FBMUX (register 4, bit 23) = 0
- BDIV (register 4, bit 9) = 0
- DIVA (register 4, bits 22:20) ≤ 100 (less than or equal to divide-by-16, which limits the minimum output frequency to 187.5MHz)
- SDN (register 2, bits 30:29) = 00
- F01 (register 5, bit 24) = 0
- DBR (register 2, bit 25) = 0
- RDIV2 (register 2, bit 24) = 0
- It is recommended to set R (register 2, bits 23:14) = 1. For other R divider values, please contact Maxim Technical Support.

When aligning the phase of multiple devices, connect their MUX and REF_IN pins together and do the following:

- 1) Force the voltage on the MUX pin to V_{IL} .
- 2) Set MUX register bits = 0111.
- 3) Program the MAX2871s for the desired frequency and allow them to lock.
- 4) Force the voltage on the MUX pins to V_{IH} . This resets the MAX2871s so they are synchronous. The MUX sync pulse rising edge cannot occur inside setup/hold time window around the reference signal rising edge:

$$t_{\text{SETUP}} = (4/N) \times t_{\text{PFD}} + 2.6\text{ns}$$

$$t_{\text{HOLD}} = (4/N) \times t_{\text{PFD}}$$

where N is the MAX2871's N counter ratio (register 0, bits 30:15) and $t_{\text{PFD}} = 1/f_{\text{PFD}}$

- 5) Optional: To use the MUX pin for other functions (i.e. register readback) in conjunction with phase synchronization, follow the steps below:
 - Force the voltage on the MUX pins back to V_{IL}
 - Set MUX register = 0000 (Hi-Z mode)
 - Remove the forced voltage from the MUX pin
 - The MUX pin is now ready for other functions
- 6) Set P (register 1, bits 26:15) for the desired amount of phase shift for each part.
- 7) Set CDM (register 3, bits 16:15) = 10.
- 8) Reset CDM = 00.

Low-Spur Mode

The device offers three modes for the sigma-delta modulator. Low-noise mode offers lower in-band noise at the expense of spurs. The spurs can be reduced by setting SDN = 10 (register 2, bits 30:29) or SDN = 11 for different modes of dithering. The user can determine which mode works best for their application.

Temperature Sensor

The device is equipped with an on-chip temperature sensor and 7-bit ADC.

To read the digitized output of the temperature sensor:

- 1) Set bits CDIV (register 3, bits 14:3) = $f_{\text{PFD}}/100\text{kHz}$ to set the clock speed for the ADC.
- 2) Set bits ADCM (register 5, bits 5:3) = 001 to enable the ADC to read the temperature.
- 3) Set bit ADCS (register 5, bit 6) = 1 to start the ADC conversion process.
- 4) Wait $100\mu\text{s}$ for the conversion process to finalize.
- 5) Read back register 6. The ADC value is located in bits 22:16.
- 6) Reset bits ADCM=0 and ADCS=0.

The approximate ambient temperature can be converted as:

$$t = 95 - 1.14 \times \text{ADC}$$

This formula is most accurate when the VCO is enabled and RFOUTA is enabled at full output power. The temperature can vary based on output power and if one or both outputs are enabled.

Register and Bit Descriptions

The operating mode of the device is controlled by five on-chip registers.

Defaults are not guaranteed upon power-up and are provided for reference only. All reserved bits should only be

written with default values. In low-power mode, the register values are retained. Upon power-up, the registers should be programmed twice with at least a 20ms pause between writes. The first write ensures that the device is enabled, and the second write starts the VCO selection process.

Table 3. Register 0 (Address: 000, Default: 007D0000_{HEX})

| BIT LOCATION | BIT ID | NAME | DEFINITION |
|--------------|------------|------------------------------|---|
| 31 | INT | Int-N or Frac-N Mode Control | 0 = Enables the fractional-N mode 1 = Enables the integer-N mode The LDF bit must also be set to the appropriate mode. |
| 30:15 | N[15:0] | Integer Division Value | Sets integer part (N-divider) of the feedback divider factor. All integer values from 16 to 65,535 are allowed for integer mode. Integer values from 0 to 15 are not allowed. Integer values from 19 to 4091 are allowed for fractional mode. |
| 14:3 | FRAC[11:0] | Fractional Division Value | Sets fractional value: 000000000000 = 0 (see F0I bit description) 000000000001 = 1 ---- 111111111110 = 4094 111111111111 = 4095 |
| 2:0 | ADDR[2:0] | Address Bits | Control Register address bits |

Table 4. Register 1 (Address: 001, Default: 2000FFF9_{HEX})

| BIT LOCATION | BIT ID | NAME | DEFINITION |
|--------------|-----------|-------------------|--|
| 31 | Reserved | Reserved | Reserved. Program to 0. |
| 30:29 | CPL[1:0] | CP Linearity | Sets CP linearity mode. 00 = Disables the CP linearity mode (integer-N mode) 01 = CP linearity 10% mode (frac-N mode) 10 = CP linearity 20% mode (frac-N mode) 11 = CP linearity 30% mode (frac-N mode) |
| 28:27 | CPT[1:0] | Charge Pump Test | Sets charge-pump test modes. 00 = Normal mode 01 = Long Reset mode 10 = Force CP into source mode 11 = Force CP into sink mode |
| 26:15 | P[11:0] | Phase Value | Sets phase value. See the Phase Adjustment section. 000000000000 = 0 000000000001 = 1 (recommended) ----- 111111111111 = 4095 |
| 14:3 | M[11:0] | Modulus Value (M) | Fractional modulus value used to program f_{VCO} . See the Int, Frac, Mod and R Counter Relationship section. Double buffered by register 0. 000000000000 = 0 000000000001 = 1 000000000010 = 2 ----- 111111111111 = 4095 |
| 2:0 | ADDR[2:0] | Address Bits | Control Register address bits |

Table 5. Register 2 (Address: 010, Default: 00004042_{HEX})

| BIT LOCATION | BIT ID | NAME | DEFINITION |
|--------------|----------|-------------------------------|--|
| 31 | LDS | Lock-Detect Speed | Lock-detect speed adjustment. 0 = $f_{PFD} \leq 32\text{MHz}$ 1 = $f_{PFD} > 32\text{MHz}$ |
| 30:29 | SDN[1:0] | Frac-N Sigma Delta Noise Mode | Sets noise mode (see the Low-Spur Mode section.) 00 = Low-noise mode 01 = Reserved 10 = Low-spur mode 1 11 = Low-spur mode 2 |
| 28:26 | MUX[2:0] | MUX Configuration | Sets MUX pin configuration (MSB bit located register 05). 0000 = Three-state output 0001 = D_VDD 0010 = D_GND 0011 = R-divider output 0100 = N-divider output/2 0101 = Analog lock detect 0110 = Digital lock detect 0111 = Sync Input 1000 : 1011 = Reserved 1100 = Read SPI registers 06 1101 : 1111 = Reserved |
| 25 | DBR | Reference Doubler Mode | Sets reference doubler mode. 0 = Disable reference doubler 1 = Enable reference doubler |
| 24 | RDIV2 | Reference Div2 Mode | Sets reference divide-by-2 mode. 0 = Disable reference divide-by-2 1 = Enable reference divide-by-2 |
| 23:14 | R[9:0] | Reference Divider Mode | Sets reference divide value (R). Double buffered by register 0. 0000000000 = 0 (unused) 0000000001 = 1 ----- 1111111111 = 1023 |

Table 5. Register 2 (Address: 010, Default: 00004042_{HEX}) (continued)

| BIT LOCATION | BIT ID | NAME | DEFINITION |
|--------------|-----------|--|--|
| 13 | REG4DB | Double Buffer | Sets double buffer mode. 0 = Disabled 1 = Enabled |
| 12:9 | CP[3:0] | Charge-Pump Current | Sets charge-pump current in mA ($R_{SET} = 5.1k\Omega$). Double buffered by register 0. $ICP = 1.63/R_{SET} \times (1+CP<3:0>)$ |
| 8 | LDF | Lock-Detect Function | Sets lock-detect function. 0 = Frac-N lock detect 1 = Int-N lock detect |
| 7 | LDP | Lock-Detect Precision | Sets lock-detect precision. 0 = 10ns 1 = 6ns |
| 6 | PDP | Phase Detector Polarity | Sets phase detector polarity. 0 = Positive 1 = Negative |
| 5 | SHDN | Shutdown Mode | Sets power-down mode. 0 = Normal mode 1 = Device shutdown |
| 4 | TRI | Charge Pump Output High-Impedance Mode | Sets charge-pump output high-impedance mode. 0 = Disabled 1 = Enabled |
| 3 | RST | Counter Reset | Sets counter reset mode. 0 = Normal operation 1 = R and N counters reset |
| 2:0 | ADDR[2:0] | Address Bits | Control Register address bits |

Table 6. Register 3 (Address: 011, Default: 0000000B_{HEX})

| BIT LOCATION | BIT ID | NAME | DEFINITION |
|--------------|------------|---------------------|---|
| 31:26 | VCO[5:0] | VCO | Manual selection of VCO and VCO sub-band when VAS is disabled. 000000 = VCO0 111111 = VCO63 |
| 25 | VAS_SHDN | VAS_SHDN | Sets VAS shutdown mode. 0 = VAS enabled 1 = VAS disabled |
| 24 | VAS_TEMP | VAS_TEMP | Sets VAS response to temperature drift. 0 = VAS temperature compensation disabled 1 = VAS temperature compensation enabled |
| 23:19 | Reserved | Reserved | Reserved. |
| 18 | CSM | CSM | Cycle Slip Mode 0 = Disable Cycle Slip Mode 1 = Enable Cycle Slip Mode |
| 17 | MUTEDEL | MUTEDEL | Mute Delay 0 = Do not delay LD to MTLTD function to prevent flickering 1 = Delay LD to MTLTD function to prevent flickering |
| 16:15 | CDM[1:0] | Clock Divider Mode | Sets clock divider mode. 00 = Mute until Lock Delay 01 = Fast-lock enabled 10 = Phase Adjustment mode 11 = Reserved |
| 14:3 | CDIV[11:0] | Clock Divider Value | Sets 12-bit clock divider value. 000000000000 = Unused 000000000001 = 1 000000000010 = 2 ----- 111111111111 = 4095 |
| 2:0 | ADDR[2:0] | Address Bits | Control Register address bits |

Table 7. Register 4 (Address: 100, Default: 6180B23C_{HEX})

| BIT LOCATION | BIT ID | NAME | DEFINITION |
|--------------|-----------|------------------------------|--|
| 31:29 | Reserved | Reserved | Reserved. Program to 011. |
| 28 | SDLDO | Shutdown VCO LDO | Sets Shutdown VCO LDO mode. 0 = Enables LDO 1 = Disables LDO |
| 27 | SDDIV | Shutdown VCO Divider | Sets Shutdown VCO Divider mode. 0 = Enables VCO Divider 1 = Disables VCO Divider |
| 26 | SDREF | Shutdown Reference Input | Sets Shutdown Reference input mode. 0 = Enables Reference Input 1 = Disables Reference Input |
| 25:24 | BS[9:8] | Band-Select MSBs | Sets Band-Select clock divider MSBs. See bits[19:12]. |
| 23 | FB | VCO Feedback Mode | Sets VCO to N counter feedback mode. 0 = Divided 1 = Fundamental |
| 22:20 | DIVA[2:0] | RFOUT_ Output Divider Mode | Sets RFOUT_ output divider mode. Double buffered by register 0 when REG4DB = 1. 000 = Divide by 1, if 3000MHz ≤ f _{RFOUTA} ≤ 6000MHz 001 = Divide by 2, if 1500MHz ≤ f _{RFOUTA} < 3000MHz 010 = Divide by 4, if 750MHz ≤ f _{RFOUTA} < 1500MHz 011 = Divide by 8, if 375MHz ≤ f _{RFOUTA} < 750MHz 100 = Divide by 16, if 187.5MHz ≤ f _{RFOUTA} < 375MHz 101 = Divide by 32, if 93.75MHz ≤ f _{RFOUTA} < 187.5MHz 110 = Divide by 64, if 46.875MHz ≤ f _{RFOUTA} < 93.75MHz 111 = Divide by 128, if 23.5MHz ≤ f _{RFOUTA} < 46.875MHz |
| 19:12 | BS[7:0] | Band Select | Sets band select clock divider value. MSB are located in bits [25:24]. 000000000 = Reserved 000000001 = 1 000000010 = 2 ---- 111111111 = 1023 |
| 11 | SDVCO | VCO Shutdown | Sets VCO Shutdown mode. 0 = Enables VCO 1 = Disables VCO |
| 10 | MTLD | RFOUT Mute until Lock Detect | Sets RFOUT Mute until Lock Detect Mode 0 = Disables RFOUT Mute until Lock Detect Mode 1 = Enables RFOUT Mute until Lock Detect Mode |
| 9 | BDIV | RFOUTB Output Path Select | Sets RFOUTB output path select. 0 = VCO divided output 1 = VCO fundamental frequency |
| 8 | RFB_EN | RFOUTB Output Mode | Sets RFOUTB output mode. 0 = Disabled 1 = Enabled |
| 7:6 | BPWR[1:0] | RFOUTB Output Power | Sets RFOUTB single-ended output power. See the RFOUTA± and RFOUTB± section. 00 = -4dBm 01 = -1dBm 10 = +2dBm 11 = +5dBm |

Table 7. Register 4 (Address: 100, Default: 6180B23C_{HEX}) (continued)

| BIT LOCATION | BIT ID | NAME | DEFINITION |
|--------------|-----------|---------------------|---|
| 5 | RFA_EN | RFOUTA Output Mode | Sets RFOUTA output mode. 0 = Disabled 1 = Enabled |
| 4:3 | APWR[1:0] | RFOUTA Output Power | Sets RFOUTA single-ended output power. See the RFOUTA± and RFOUTB± section. 00 = -4dBm 01 = -1dBm 10 = +2dBm 11 = +5dBm |
| 2:0 | C[2:0] | Register Address | Control Register address bits |

Table 8. Register 5 (Address: 101, Default: 00400005_{HEX})

| BIT LOCATION | BIT ID | NAME | DEFINITION |
|--------------|-----------|--------------------------|--|
| 31 | Reserved | Reserved | Reserved .Program to 0. |
| 30:29 | VAS_DLY | VAS_DLY | VCO Autoselect Delay. Program to 11 when VAS_TEMP=1 Program to 00 when VAS_TEMP=0 |
| 28:26 | Reserved | Reserved | Reserved .Program to 000. |
| 25 | SDPLL | Shutdown PLL | Sets Shutdown PLL mode. 0 = Enables PLL 1 = Disables PLL |
| 24 | F01 | F01 | Sets integer mode for F = 0. 0 = If F[11:0] = 0, then fractional-N mode is set 1 = If F[11:0] = 0, then integer-N mode is auto set |
| 23:22 | LD[1:0] | Lock-Detect Pin Function | Sets lock-detect pin function. 00 = Low 01 = Digital lock detect 10 = Analog lock detect 11 = High |
| 21:19 | Reserved | Reserved | Reserved. Program to 000. |
| 18 | MUX[3] | MUX MSB | Sets mode at MUX pin (see register 2 [28:26]) |
| 17:7 | Reserved | Reserved | Reserved. Program to 0000000000. |
| 6 | ADCS | ADC Start | Sets ADC Start mode. 0 = ADC normal operation 1 = Start ADC conversion process |
| 5:3 | ADCM[2:0] | ADC Mode | Sets ADC mode. 000 = Disabled 001 = Temperature sensor 010 = Reserved 011 = Reserved 100 = Tune pin 101 = Reserved 110 = Reserved 111 = Reserved |
| 2:0 | ADDR[2:0] | Register Address | Control Register address bits |

Table 9. Register 6 (Read-Only Register)

| BIT LOCATION | BIT ID | NAME | DEFINITION |
|--------------|-----------|------------------|--|
| 31:28 | DIE[3:0] | Die ID | Die ID. 0110 = MAX2870 0111 = MAX2871 |
| 27:24 | Reserved | Reserved | Reserved. |
| 23 | POR | Power On Reset | Power-On-Reset 0 = Power has not been cycled since last read 1 = Power has not been cycled since last read. All registers have been reset to default values. |
| 22:16 | ADC[6:0] | ADC Code | ADC Code. |
| 15 | ADCV | ADC Valid | Determines ADC code validity. 0 = Invalid ADC code 1 = Valid ADC code |
| 14:10 | Reserved | Reserved | Reserved. |
| 9 | VASA | VAS Active | Determines if VAS is Active. 0 = VCO Autoselect complete 1 = VCO Autoselect searching for correct VCO |
| 8:3 | V[5:0] | Current VCO | Current VCO. |
| 2:0 | ADDR[2:0] | Register Address | Control Register address bits. |

Typical Application Circuit

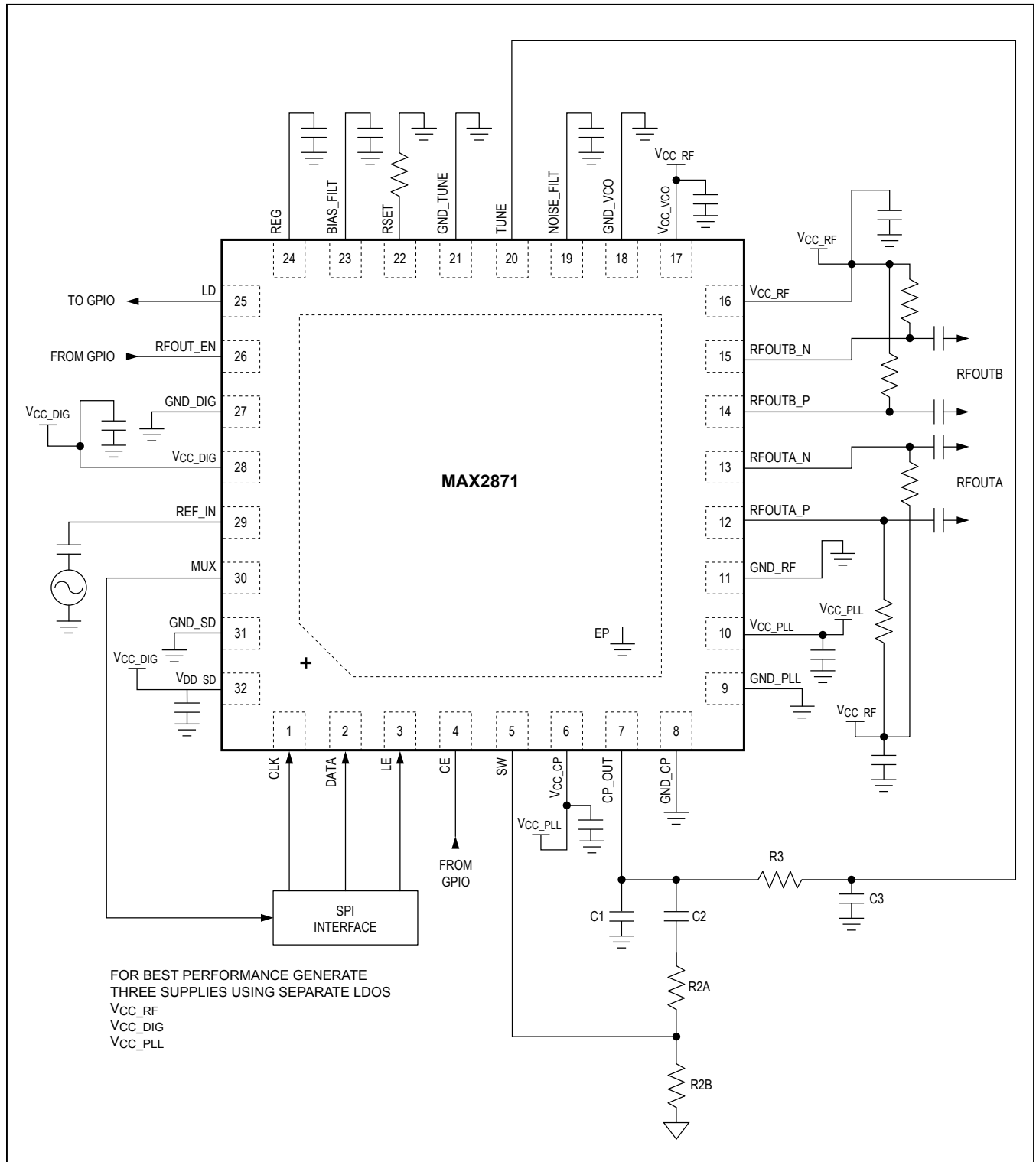

MAX2871

23.5MHz to 6000MHz Fractional/
Integer-N Synthesizer/VCO

Ordering Information

| PART | TEMP RANGE | PIN-PACKAGE |
|-------------|----------------|-------------|
| MAX2871ETJ+ | -40°C to +85°C | 32 TQFN-EP* |

+Denotes lead(Pb)-free/RoHS-compliant package.

*EP = Exposed pad.

Package Information

For the latest package outline information and land patterns (footprints), go to www.maximintegrated.com/packages. Note that a "+", "#", or "-" in the package code indicates RoHS status only. Package drawings may show a different suffix character, but the drawing pertains to the package regardless of RoHS status.

| PACKAGE TYPE | PACKAGE CODE | OUTLINE NO. | LAND PATTERN NO. |
|--------------|--------------|-------------------------|-------------------------|
| 32 TQFN-EP | T3255+5 | 21-0140 | 90-0013 |

Revision History

| REVISION NUMBER | REVISION DATE | DESCRIPTION | PAGES CHANGED |
|-----------------|---------------|--|-------------------|
| 0 | 9/14 | Initial release | — |
| 1 | 4/15 | Updated phase adjustment section and other minor updates to data sheet | 1, 13, 17, 19, 24 |

For pricing, delivery, and ordering information, please contact Maxim Direct at 1-888-629-4642, or visit Maxim Integrated's website at www.maximintegrated.com.

Maxim Integrated cannot assume responsibility for use of any circuitry other than circuitry entirely embodied in a Maxim Integrated product. No circuit patent licenses are implied. Maxim Integrated reserves the right to change the circuitry and specifications without notice at any time. The parametric values (min and max limits) shown in the Electrical Characteristics table are guaranteed. Other parametric values quoted in this data sheet are provided for guidance.

Данный компонент на территории Российской Федерации

Вы можете приобрести в компании MosChip.

Для оперативного оформления запроса Вам необходимо перейти по данной ссылке:

<http://moschip.ru/get-element>

Вы можете разместить у нас заказ для любого Вашего проекта, будь то серийное производство или разработка единичного прибора.

В нашем ассортименте представлены ведущие мировые производители активных и пассивных электронных компонентов.

Нашей специализацией является поставка электронной компонентной базы двойного назначения, продукции таких производителей как XILINX, Intel (ex.ALTERA), Vicor, Microchip, Texas Instruments, Analog Devices, Mini-Circuits, Amphenol, Glenair.

Сотрудничество с глобальными дистрибьюторами электронных компонентов, предоставляет возможность заказывать и получать с международных складов практически любой перечень компонентов в оптимальные для Вас сроки.

На всех этапах разработки и производства наши партнеры могут получить квалифицированную поддержку опытных инженеров.

Система менеджмента качества компании отвечает требованиям в соответствии с ГОСТ Р ИСО 9001, ГОСТ РВ 0015-002 и ЭС РД 009

Офис по работе с юридическими лицами:

105318, г.Москва, ул.Щербаковская д.3, офис 1107, 1118, ДЦ «Щербаковский»

Телефон: +7 495 668-12-70 (многоканальный)

Факс: +7 495 668-12-70 (доб.304)

E-mail: info@moschip.ru

Skype отдела продаж:

moschip.ru

moschip.ru_4

moschip.ru_6

moschip.ru_9