

### LSP10 Module Series



#### Agency Approvals

Agency	Standard	Agency File Number
	UL1449	E320116

#### Applications

- Outdoor and Commercial LED Lighting
- Roadway lighting
- Traffic lighting
- Digital signage
- Wash wall lighting
- Parking garage/lot lighting
- Flood lighting
- Tunnel lighting
- Street lighting

#### Additional Information



Datashheet



Resources



Samples

#### Description

The Littelfuse LSP10 thermally protected Surge Protective Device is a self-protected device which is specially designed to be used in outdoor and commercial LED lighting fixtures for transient overvoltage protection. It is constructed with Littelfuse thermally protected varistor technology. Its built-in thermal disconnect function provides additional protection to prevent catastrophic failure and fire hazard even under the extreme circumstances of varistor end-of-life or sustaining over voltage conditions. LSP10 series connected option allows clear indication of thermal fault protection by disconnecting power to luminaire thereby signally SPD module replacement. The LSP10 SPD facilitates customer's product compliance to IEEE C62.41.2 Location Category C High and US Dept of Energy MSSLC Model Spec.

#### Features

- Maximum Discharge Current, 20kA, 8/20 $\mu$ s
- Meets ANSI C136.2 Extreme Level 20kV/10kA and IEEE C62.41.2 Location Category C High Exposure
- Parallel connected and Series connected SPD options
- Thermally protected Varistor technology
- IP66 Water-proof and Dust-proof
- Series connected – Varistor thermal protection indication by removal of power to luminaire
- Indication wire lead options for Parallel connected modules
- IEC61643-11 Class II/ EN61643-11 Type 2 Compliant<sup>1</sup>
- Compact form factor (48x48x30mm) with mounting tabs
- 240Vac and 277Vac are CE compliant and available for Class I and Class II installation based on IEC luminaire protection classes. Please see details in Part Numbering System.

Notes:

1. Self-declared compliance.\*

#### Absolute Maximum Ratings

\* For ratings of individual members of a series, see Device Ratings and Specifications chart

	LSP10 Series	Units
<b>Continous:</b>		
AC Voltage Range ( $V_{M(AC)RMS}$ )	150 to 510	V
Continuous Current*	5	A
<b>Transient:</b>		
Maximum Discharge Current 8/20 $\mu$ s Waveform ( $I_{max}$ )	20,000	A
Nominal Discharge Current 8/20 $\mu$ s Waveform ( $I_n$ )	10,000	A
Operating Ambient Temperature Range ( $T_A$ )	-45 to +85	°C
Storage Temperature Range ( $T_{STG}$ )	-45 to +110	°C
Isolation Voltage Capability (When the thermal disconnect opens)	600	V
Insulation Resistance	>1,000	M $\Omega$

Note: \* = Max. continuous current for series connection.

**CAUTION:** Stresses above those listed in "Absolute Maximum Ratings" may cause permanent damage to the device. This is a stress only rating and operation of the device at these or any other conditions above those indicated in the operational sections of this specification is not implied.

**LSP10 Series Device Ratings & Specifications**

Part Number <sup>8</sup>	Operating Voltage (VAC)	MCOV/Uc (VAC) <sup>6</sup>	Maximum Discharge Current (Imax)(A) <sup>3</sup>	Nominal Discharge Current (In)(A) <sup>2</sup>	MLV (V) <sup>4</sup>	Up (V) <sup>5</sup>	Safety Compliance	
							IEC/EN 61643-11 <sup>7</sup>	UL1449
LSP10120*	120	150	20,000	10,000	L-N:740 L-G:740 N-G:670	900		X
LSP10240*	240	275	20,000	10,000	L-N:1130 L-G:1130 N-G:1060	1200	X	X
LSP10277*	277	320	20,000	10,000	L-N:1330 L-G:1330 N-G:1260	1400	X	X
LSP10347*	347	420	20,000	10,000	L-N:1750 L-G:1750 N-G:1680	1900		X
LSP10480*	480	510	20,000	10,000	L-N:2020 L-G:2020 N-G:1960	2100		X
LSP10240LL*	L-L:240	L-L:275	20,000	10,000	L-L:1130	L-L:1200		X
	L-N/G:120	L-N/G:150			L-N/G:740	L-N/G:900		X
LSP10480LL*	L-L:480	L-L:510	20,000	10,000	L-L:2020	L-L:2100		X
	L-N/G:277	L-N/G:320			L-N/G:1330	L-N/G:1400		X

- NOTES:
- 5A max. continuous current for series connection.
  - Nominal Discharge Current (In)(A): The nominal discharge current is a measure of the SPDs endurance capability; 15 impulses of discharge current uses the 8/20us current waveform.
  - Maximum Discharge Current (Imax)(A): The maximum discharge current is a measure of the SPDs maximum capability; single impulse of discharge current uses the 8/20us current waveform. All Devices pass maximum discharge current with possible, safe opening of thermal disconnect.
  - MLV – UL1449 Measured limiting voltage; the highest value of residual voltage measurements during the application of impulses of 8/20us nominal discharge current (In); an average voltage value of 15 impulses.
  - Up – IEC 61643-11 Voltage protection level; the highest value of residual voltage measurements during the application of impulses of 8/20us nominal discharge current (In); a rounding voltage value of maximum measurement.
  - MCOV/UC: Maximum Continuous Operating Voltage - maximum r.m.s. voltage that could be continuously applied to the SPD.
  - Series module used in parallel connection for indication circuit connection.
  - \* = - P or PM

**Dimensions**

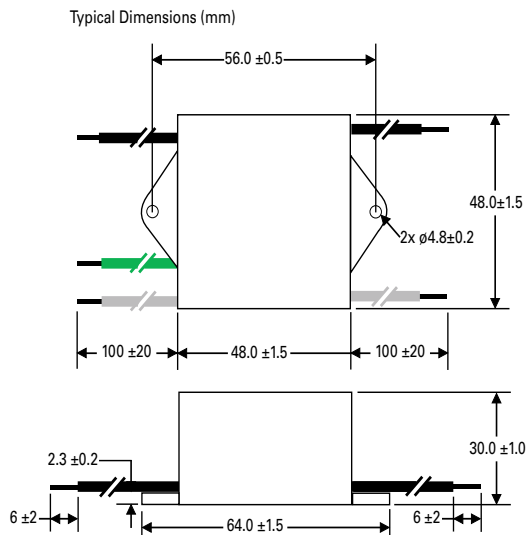

- Notes:
- Black: Line; White: Neutral; Green: Ground.  
(P/N with suffix X3333/X3316: Brown: Line; Blue: Neutral; Green-Yellow stripe: Ground)
  - Wire Gauge: AWG14 wire Line in/out; Wire Length: 100mm or customized.

### Application/Installation Schematic



- Notes:
1. Series module used in parallel connection for indication circuit connection.
  2. LED indicator and associated circuitry are not included in the module.
  3. Black wire is AC line voltage (hot); white wire is AC neutral voltage.
  4. Black wire voltage is cut off when SPD needs replacement.
  5. R is current limiting resistor; its resistance/wattage is determined by AC line voltage and desired current driving LED. Example: AC line voltage 240V, LED: 1.6mA, resistor: 150Kohm/0.5W.

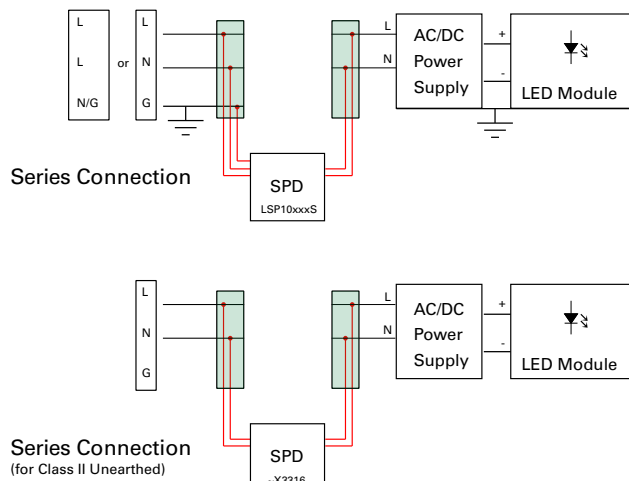

### Part Numbering System



## Данный компонент на территории Российской Федерации

### Вы можете приобрести в компании MosChip.

Для оперативного оформления запроса Вам необходимо перейти по данной ссылке:

<http://moschip.ru/get-element>

Вы можете разместить у нас заказ для любого Вашего проекта, будь то серийное производство или разработка единичного прибора.

В нашем ассортименте представлены ведущие мировые производители активных и пассивных электронных компонентов.

Нашей специализацией является поставка электронной компонентной базы двойного назначения, продукции таких производителей как XILINX, Intel (ex.ALTERA), Vicor, Microchip, Texas Instruments, Analog Devices, Mini-Circuits, Amphenol, Glenair.

Сотрудничество с глобальными дистрибьюторами электронных компонентов, предоставляет возможность заказывать и получать с международных складов практически любой перечень компонентов в оптимальные для Вас сроки.

На всех этапах разработки и производства наши партнеры могут получить квалифицированную поддержку опытных инженеров.

Система менеджмента качества компании отвечает требованиям в соответствии с ГОСТ Р ИСО 9001, ГОСТ РВ 0015-002 и ЭС РД 009

### Офис по работе с юридическими лицами:

105318, г.Москва, ул.Щербаковская д.3, офис 1107, 1118, ДЦ «Щербаковский»

Телефон: +7 495 668-12-70 (многоканальный)

Факс: +7 495 668-12-70 (доб.304)

E-mail: [info@moschip.ru](mailto:info@moschip.ru)

Skype отдела продаж:

moschip.ru

moschip.ru\_4

moschip.ru\_6

moschip.ru\_9