

Scalable digital microphone processor

Datasheet - production data

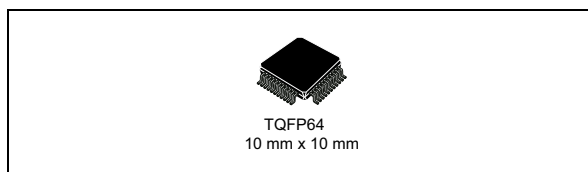

Features

- 8 digital processing channels each 24-bits
 - 6 channels of PDM input
 - 2 additional virtual channels
- >100 dB SNR and dynamic range
- Digital gain/attenuation 58 dB to -100 dB in 0.5 dB steps
- Soft volume update
- Individual channel and master level control
- Up to 10 independent 32-bit user-programmable biquads (EQ) per channel
- Bass/treble tone control
- Pre- and post-EQ full 8-channel input mix on all 8 channels
- Dual independent limiters/compressors
- Dynamic range compression or anti-clipping modes
- Individual channel and master soft/hard mute
- 3 I²S data outputs
- I²S data output channel mapping function
- Independent channel volume and DSP bypass
- Channel mapping of any input to any processing channel

Applications

- Tablets
- Gaming
- Audio conference sets
- Legacy microphone-equipped devices

Description

The STA321MPL1 is a PDM, high-performance, multichannel processor with ultra-low quiescent current. It is designed for general-purpose digital microphone applications. The device is fully digital and is comprised of three main sections. The first section is the PDM input interface which can accept up to six serial digital inputs. The second section is a high-quality audio processor allowing flexible channel mixing/muxing and provides up to 10 biquads for general sound equalization and voice enhancement with independent volume control. The last block is the I²S output interface which streams out the processed digital audio. The output interface can also be programmed for flexible channel mapping. The device offers some of the most commonly required audio enhancements such as programmable voice tuning and equalization, limiter/compressor for improved voice quality, multiband selection for customizable microphone usage, and configurable wind-noise rejection. The embedded digital processor allows the microphone processing to be offloaded from the main CPU or SoC to the device.

The STA321MPL1 has six digital microphone inputs, providing connections for up to three dual-membrane microphones.

Table 1. Device summary

Order code	Package	Packaging
STA321MPL1TR	TQFP64	Tape and reel

Contents

- 1 Device overview 7**
 - 1.1 Block diagram 7
 - 1.2 Pin description 8

- 2 Electrical characteristics 11**
 - 2.1 Absolute maximum ratings11
 - 2.2 Thermal data11
 - 2.3 Recommended operating conditions11
 - 2.4 Electrical specifications 12

- 3 Microphone interface 13**
 - 3.1 PDM clock generator (for microphones) 13
 - 3.2 PDM resampling interface 14
 - 3.3 PDM recombination (dual-membrane microphone support) 15
 - 3.4 Low-pass filter 15
 - 3.5 Sensitivity adjustment 16
 - 3.6 Normal channel attenuation 16
 - 3.7 Thresholds 16

- 4 I²C bus operation 17**
 - 4.1 Communication protocol 17
 - 4.1.1 Data transition or change 17
 - 4.1.2 Start condition 17
 - 4.1.3 Stop condition 17
 - 4.1.4 Data input 17
 - 4.2 Device addressing 17
 - 4.3 Write operation 18
 - 4.3.1 Byte write 18
 - 4.3.2 Multi-byte write 18
 - 4.4 Read operation 19
 - 4.4.1 Current address byte read 19
 - 4.4.2 Current address multi-byte read 19
 - 4.4.3 Random address byte read 19

4.4.4 Random address multi-byte read 19

5 Registers 20

5.1 Register summary 20

5.2 Register description 24

5.2.1 Configuration register A (0x00) 24

5.2.2 Configuration register C (0x02) - serial output formats 26

5.2.3 Configuration register D (0x03) 28

5.2.4 Configuration register E (0x04) 29

5.2.5 Configuration register F (0x05) 29

5.2.6 Configuration register G (0x06) 31

5.2.7 Configuration register H (0x07) 32

5.2.8 Configuration register I (0x08) 33

5.2.9 Master mute register (0x09) 34

5.2.10 Master volume register (0x0A) 34

5.2.11 Channel 1 volume (0x0B) 34

5.2.12 Channel 2 volume (0x0C) 34

5.2.13 Channel 3 volume (0x0D) 34

5.2.14 Channel 4 volume (0x0E) 34

5.2.15 Channel 5 volume (0x0F) 35

5.2.16 Channel 6 volume (0x10) 35

5.2.17 Channel 7 volume (0x11) 35

5.2.18 Channel 8 volume (0x12) 35

5.2.19 Channel 1 volume trim, mute, bypass (0x13) 35

5.2.20 Channel 2 volume trim, mute, bypass (0x14) 35

5.2.21 Channel 3 volume trim, mute, bypass (0x15) 35

5.2.22 Channel 4 volume trim, mute, bypass (0x16) 36

5.2.23 Channel 5 volume trim, mute, bypass (0x17) 36

5.2.24 Channel 6 volume trim, mute, bypass (0x18) 36

5.2.25 Channel 7 volume trim, mute, bypass (0x19) 36

5.2.26 Channel 8 volume trim, mute, bypass (0x1A) 36

5.2.27 Fine volume (FineVol) (0x5B) 36

5.2.28 Channel input mapping channels 1 and 2 (0x1B) 38

5.2.29 Channel input mapping channels 3 and 4 (0x1C) 38

5.2.30 Channel input mapping channels 5 and 6 (0x1D) 38

5.2.31 Channel input mapping channels 7 and 8 (0x1E) 38

5.2.32 AGEQ - graphic EQ 80-Hz band (0x23) 39

5.2.33 BGEQ - graphic EQ 300-Hz band (0x24) 39

5.2.34 CGEQ - graphic EQ 1-kHz band (0x25) 39

5.2.35 DGEQ - graphic EQ 3-kHz band (0x26) 39

5.2.36 EGEG - graphic EQ 8-kHz band (0x27) 40

5.2.37 Biquad internal channel loop-through (0x28) 40

5.2.38 Mix internal channel loop-through (0x29) 41

5.2.39 EQ bypass (0x2A) 41

5.2.40 Tone control bypass (0x2B) 41

5.2.41 Tone control (0x2C) 42

5.2.42 Channel limiter select channels 1, 2, 3, 4 (0x2D) 42

5.2.43 Channel limiter select channels 5, 6, 7, 8 (0x2E) 42

5.2.44 Limiter 1 attack/release rate (0x2F) 42

5.2.45 Limiter 1 attack/release threshold (0x30) 43

5.2.46 Limiter 2 attack/release rate (0x31) 43

5.2.47 Limiter 2 attack/release threshold (0x32) 43

5.2.48 Limiter description 43

5.2.49 Channel 1 and 2 output timing (0x33) 47

5.2.50 Channel 3 and 4 output timing (0x34) 47

5.2.51 Channel 5 and 6 output timing (0x35) 47

5.2.52 Channel 7 and 8 output timing (0x36) 48

5.2.53 Coefficient address register 1 (0x3B) 48

5.2.54 Coefficient address register 2 (0x3C) 48

5.2.55 Coefficient b1 data register, bits 23:16 (0x3D) 48

5.2.56 Coefficient b1 data register, bits 15:8 (0x3E) 49

5.2.57 Coefficient b1 data register, bits 7:0 (0x3F) 49

5.2.58 Coefficient b2 data register, bits 23:16 (0x40) 49

5.2.59 Coefficient b2 data register, bits 15:8 (0x41) 49

5.2.60 Coefficient b2 data register, bits 7:0 (0x42) 49

5.2.61 Coefficient a1 data register, bits 23:16 (0x43) 49

5.2.62 Coefficient a1 data register, bits 15:8 (0x44) 49

5.2.63 Coefficient a1 data register, bits 7:0 (0x45) 50

5.2.64 Coefficient a2 data register, bits 23:16 (0x46) 50

5.2.65 Coefficient a2 data register, bits 15:8 (0x47) 50

5.2.66 Coefficient a2 data register, bits 7:0 (0x48) 50

5.2.67 Coefficient b0 data register, bits 23:16 (0x49) 50

5.2.68 Coefficient b0 data register, bits 15:8 (0x4A) 50

5.2.69 Coefficient b0 data register, bits 7:0 (0x4B) 50

5.2.70	Coefficient write control register (0x4C)	51
5.3	Reading a coefficient from RAM	52
5.4	Reading a set of coefficients from RAM	52
5.5	Writing a single coefficient to RAM	52
5.6	Writing a set of coefficients to RAM	53
6	Configuration registers (0x77; 0x78; 0x79)	54
6.1	Post-scale	56
6.2	Variable max power correction	58
6.2.1	MPCC1-2 (0x4D, 0x4E)	58
6.3	Variable distortion compensation	58
6.3.1	DCC1-2 (0x4F, 0x50)	58
6.4	PSCorrect registers	59
6.4.1	PSC1-2: ripple correction value (RCV) (0x51, 0x52)	59
6.4.2	PSC3: correction normalization value (CNV) (0x53)	59
6.5	PDM and recombination IP	60
6.5.1	Mike recombination RAM BIST (0x5C)	60
6.5.2	Recombination control register 1 (0x5D)	60
6.5.3	PDM control register (0x5E)	61
6.5.4	Recombination control register 2, 3, and 4 (0x5F; 0x60; 0x61)	61
6.5.5	Recombination control register 5, 6, and 7 (0x62; 0x63; 0x64)	63
6.5.6	Recombination control register 8, 9, and 10 (0x65; 0x66; 0x67)	65
6.5.7	Recombination control register 11, 12, and 13 (0x68; 0x69; 0x6A)	66
6.5.8	Zero-mute threshold/hysteresis and RMS zero-mute selectors (0x6F)	67
6.5.9	RMS post-processing selectors and Fs autodetection (0x70)	69
6.5.10	Clock manager configuration	70
6.5.11	RMS level registers (0x7A, 0x7B, 0x7C, 0x7D)	72
7	Startup/shutdown pop noise removal	75
7.1	DPT: PWM and tristate delay (0x80)	75
7.2	Configuration register (0x81)	75
7.3	User-defined delay time (0x82) and (0x83)	76
8	Package information	77
8.1	TQFP64 (10 mm x 10 mm) package information	78

9 **Revision history** **79**

1 Device overview

1.1 Block diagram

Figure 1. Block diagram

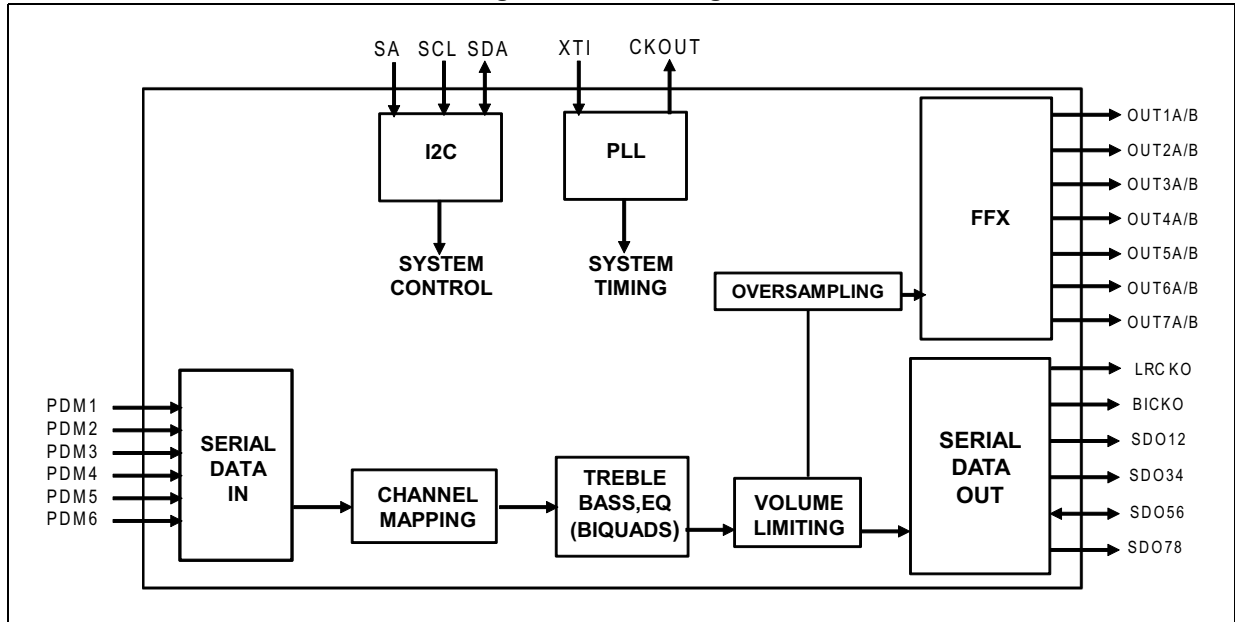
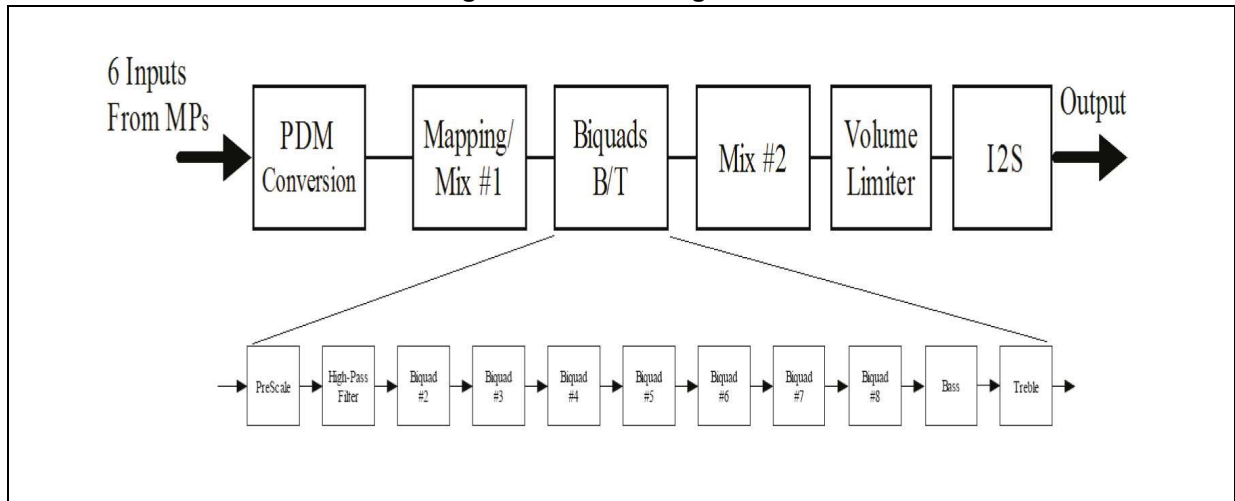

Figure 2. Channel signal flow



1.2 Pin description

Figure 3. Pin connections (top view)

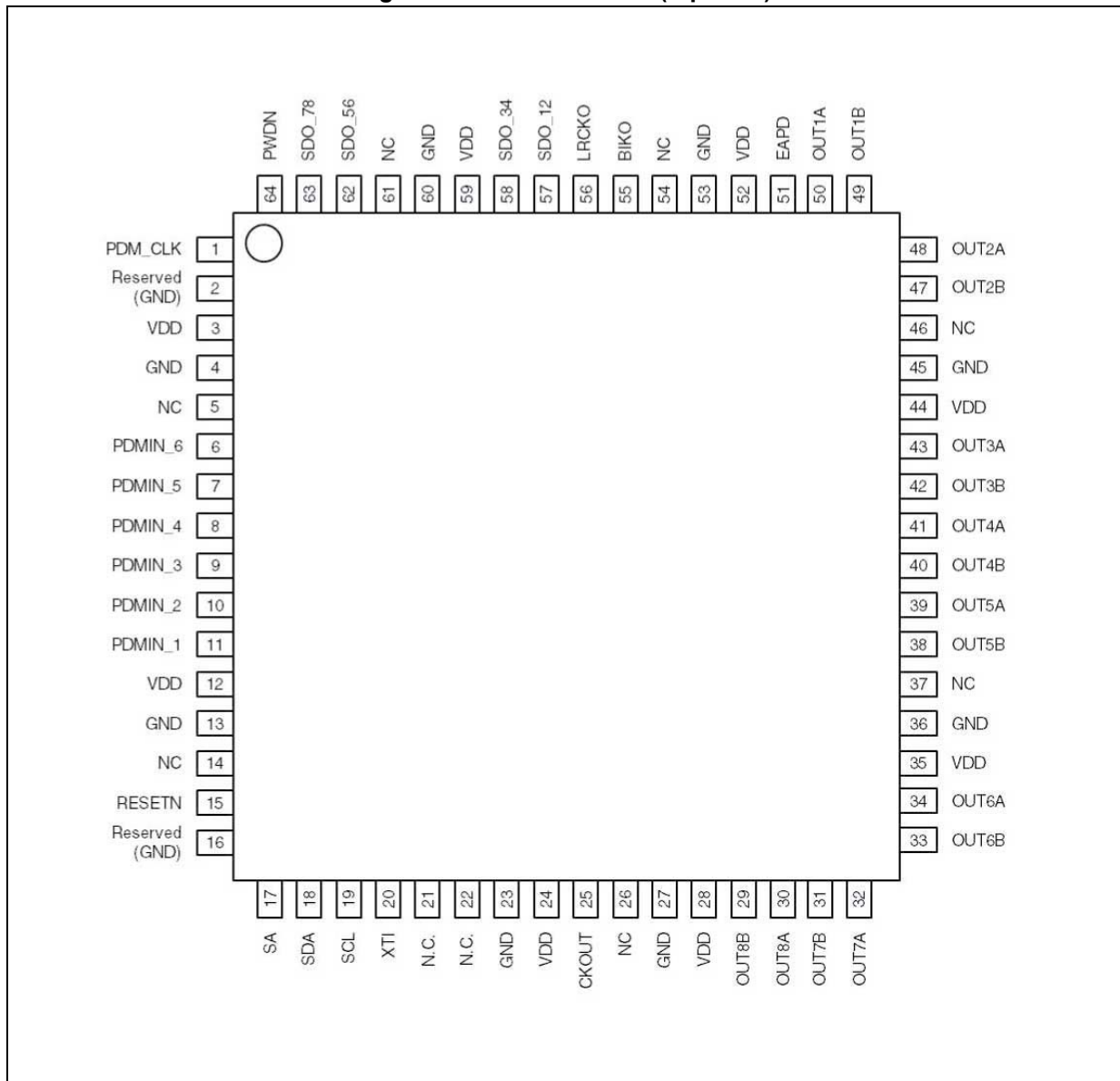

Table 2. Pin description

Pin number	Type	Name	Description	
1	5-V tolerant TTL input buffer	PDM_CLK	PDM I/F CLK	
6		PDMIN_6	PDM input channel 6	
7		PDMIN_5	PDM input channel 5	
8		PDMIN_4	PDM input channel 4	
9		PDMIN_3	PDM input channel 3	
10		PDMIN_2	PDM input channel 2	
11		PDMIN_1	PDM input channel 1	
15	5-V tolerant TTL Schmitt trigger input buffer	RESETN	Global reset	
16	CMOS input buffer with pull-down	PLLB	Bypass phase-locked loop	
17	1.8-V CMOS input buffer with pull-down	SA	Select address (I ² C)	
18	Bidirectional buffer: 5-V tolerant TTL Schmitt trigger input; 3.3-V capable 2 mA slew-rate controlled output	SDA	Serial data (I ² C)	
19	5-V tolerant TTL Schmitt trigger input buffer	SCL	Serial clock (I ² C)	
20		XTI	Crystal oscillator input (clock input)	
21		NC	Not connected	
23	Analog ground	GND	PLL ground	
25	3.3-V capable TTL tristate 4 mA output buffer	CKOUT	Clock output	
29	3.3-V capable TTL 2 mA output buffer	OUT8B	PWM channel 8 output B	
30		OUT8A	PWM channel 8 output A	
31		OUT7B	PWM channel 7 output B	
32		OUT7A	PWM channel 7 output A	
33		OUT6B	PWM channel 6 output B	
34		OUT6A	PWM channel 6 output A	
38		OUT5B	PWM channel 5 output B	
39		OUT5A	PWM channel 5 output A	
40		OUT4B	PWM channel 4 output B	
41		OUT4A	PWM channel 4 output A	
42		OUT3B	PWM channel 3 output B	
43		OUT3A	PWM channel 3 output A	
47		OUT2B	PWM channel 2 output B	
48		OUT2A	PWM channel 2 output A	
49		OUT1B	PWM channel 1 output B	
50		OUT1A	PWM channel 1 output A	
51		3.3-V capable TTL 4 mA output buffer	EAPD	Ext. amp power-down

Table 2. Pin description (continued)

Pin number	Type	Name	Description
55	3.3-V capable TTL 2 mA output buffer	BICKO	Output serial clock
56		LRCKO	Output left/right clock
57		SDO_12	Output serial data channels 1 and 2
58		SDO_34	Output serial data channels 3 and 4
62		SDO_56	Output serial data channels 5 and 6
63		SDO_78	Output serial data channels 7 and 8
64		5-V tolerant TTL Schmitt trigger input buffer	PWDN
3, 12, 24, 28, 35, 44, 52, 59	3.3-V digital supply voltage	VDD	3.3-V supply
2, 4, 13, 27, 36, 45, 53, 60	Digital ground	GND	Ground
14, 21, 22, 26, 37, 46, 54, 61		NC	Not connected

2 Electrical characteristics

2.1 Absolute maximum ratings

Table 3. Absolute maximum ratings

Symbol	Parameter	Min	Typ	Max	Unit
V _{DD}	3.3-V I/O power supply	-0.5	—	4	V
V _{SA}	Voltage on SA pin (17)	-0.5		2	
V _i	Voltage on input pins	-0.5		VDD + 0.5	
V _o	Voltage on output pins	-0.5		VDD + 0.3	
T _{stg}	Storage temperature	-40		150	°C
T _{amb}	Ambient operating temperature	-40		90	

2.2 Thermal data

Table 4. Thermal data

Symbol	Parameter	Min	Typ	Max	Unit
R _{thj-amb}	Thermal resistance, junction-to-ambient	—	85	—	°C/W

2.3 Recommended operating conditions

Table 5. Recommended operating conditions

Symbol	Parameter	Min	Typ	Max	Unit
V _{DD}	I/O power supply	3.0	3.3	3.6	V
V _{SA}	Voltage on SA pin (17)	1.55	1.8	1.95	
T _j	Operating junction temperature	-40	25	125	°C

2.4 Electrical specifications

The following specifications are valid for $V_{DD} = 3.3 \text{ V} \pm 0.3 \text{ V}$, $V_{SA} = 0 \text{ V}$ and $T_{amb} = 25 \text{ }^\circ\text{C}$, unless otherwise stated.

Table 6. General interface electrical specifications

Symbol	Parameter	Conditions	Min	Typ	Max	Unit
I_{il}	Low-level input, no pull-up	$V_i = 0 \text{ V}$		—	1	μA
I_{ih}	High-level input, no pull-down	$V_i = V_{DD}$			2	
I_{OZ}	Tristate output leakage without pull-up/down	$V_i = V_{DD}$			2	
V_{esd}	Electrostatic protection, human body model	Leakage $< 1 \mu\text{A}$	2000			V

Table 7. DC electrical characteristics: 3.3-V buffers

Symbol	Parameter	Conditions	Min	Typ	Max	Unit
V_{IL}	Low-level input voltage				0.8	V
V_{IH}	High-level input voltage		2.0			
V_{ILhyst}	Low-level threshold	Input falling	0.8		1.35	
V_{IHhyst}	High-level threshold	Input rising	1.3		2.0	
V_{hyst}	Schmitt trigger hysteresis		0.3		0.8	
V_{ol}	Low-level output	$I_{ol} = 100 \mu\text{A}$			0.2	
V_{oh}	High-level output	$I_{oh} = -100 \mu\text{A}$	$V_{DD} - 0.2$			
		$I_{oh} = -2 \text{ mA}$	2.4			
I_{dd}	Quiescent current	Reset conditions		15		mA
		Normal conditions with CKOUT		60		

3 Microphone interface

3.1 PDM clock generator (for microphones)

To correctly start the device in microphone processor mode, it is necessary to set registers 0x00 to 0x9B and register 0x5D to 0x01.

The CKOUT pin can be used to properly provide a clock source for digital microphones.

When the mikemode bit is asserted (reg 0x5D bit 0), the CKOUT generator is automatically configured to generate a clock with $\text{sys_clk}/32$ frequency (corresponding to a PDM over-sampling rate of 64).

For example, considering a base sample frequency of:

Fs = 44.1 kHz

XTI = 11.289 MHz (user provided)

System clock = 90.3168 MHz (system generated)

Clock out = 2.8224 MHz (system generated)

Fs = 48.0 kHz

XTI = 12.288 MHz (user provided)

System clock = 98.304 MHz (system generated)

Clock out = 3.072 MHz (system generated)

Technical details

The clock generator creates two output clocks with the same frequency, CKOUT270 has a 270 degrees phase shift with respect to CKOUT. One is exported outside the device and used to clock the microphones, the other is used internally to clock the PDM interface of the STA321MPL1.

Figure 4. PDM clock generator

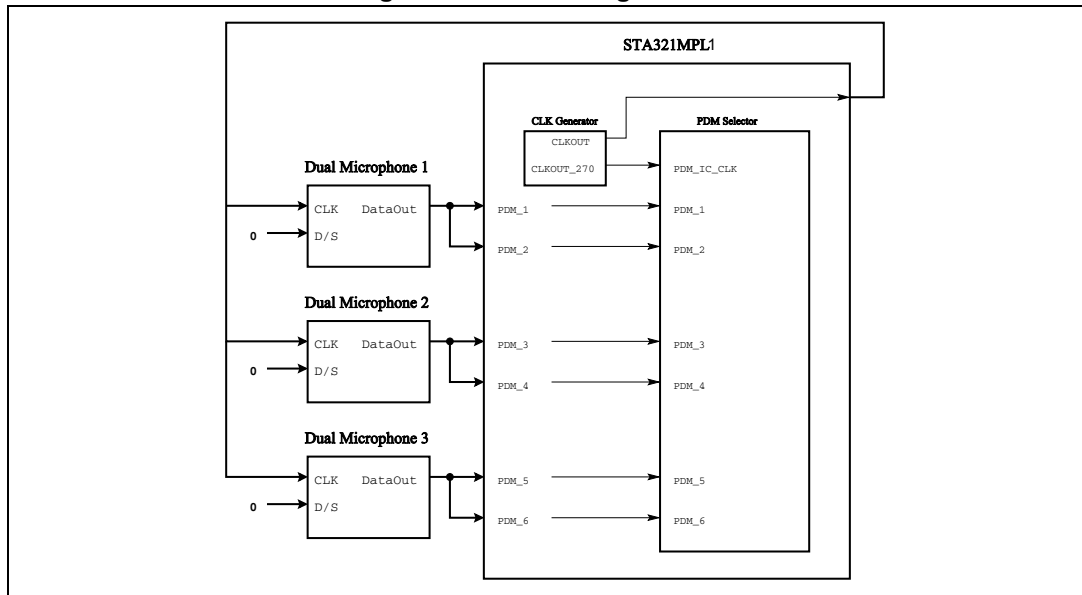

3.2 PDM resampling interface

The PDM resampling interface is used to properly sample external data.

It can work in three different modes: compatibility mode, dual-membrane mode and advanced mode. In each mode, data are sampled at the rising or falling edge.

Table 8. Modes for PDM resampling interface

Mode	Behavior
00	Compatibility (old)
01	Reserved
10	Dual-membrane
11	Advanced

Compatibility mode

In this mode every channel is sampled at the rising edge.

Dual-membrane mode

The dual-membrane mode is a particular configuration (automatically applied when the proper bit is asserted) which permits the use of the dual-membrane microphone. In particular, it has 2 PDM data channels (normal and high) muxed in a single wire. The normal channel is sampled at the falling edge, while the high channel is sampled at the rising edge.

Advanced mode

In this mode every channel can be sampled at the rising or falling edge according to the configuration register.

3.3 PDM recombination (dual-membrane microphone support)

Dual microphone scenario:

A dual-membrane microphone has two separate PDM signal paths:

- Normal channel for moderate SPL (sound pressure level) acoustic signals
- High channel for high SPL acoustic signals

The sensitivity of the high channel is configurable and is set by default to 20 dB SPL lower than the sensitivity of the normal channel to avoid saturation in any part of the signal path.

The two channels can be combined together to enlarge the dynamic range and have a good trade-off between the DNR and the noise floor (which is lower in the case of the normal channel).

The main functionality is based on a signal level measurement and a dual-threshold system.

If the signal of the normal channel is:

- above the upper threshold (TH_H), the output is taken from the high channel
- under the lower threshold (TH_N), the output is taken from the normal channel
- between TH_H and TH_N, the output is a combination of the high and normal channels.

Figure 5. PDM recombination block diagram

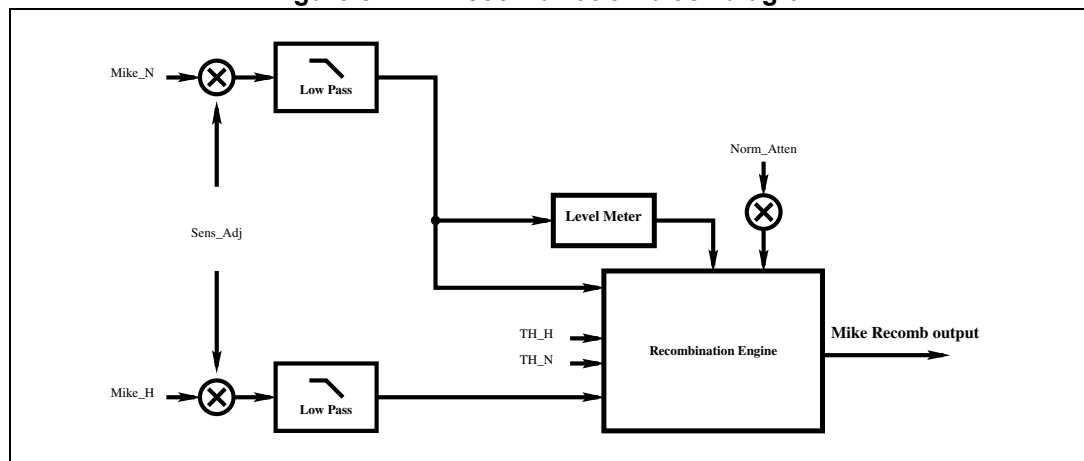

3.4 Low-pass filter

A filter is provided (and needed) to suppress the noise outside the audio band that may be still present before the recombination stage.

The filter is a 2nd order IIR (infinite impulse response) low-pass with a cutoff frequency of 20 kHz. It can be bypassed through the I²C bit.

Configuration registers: 0x62(6), 0x63(6), 0x64(6)

3.5 Sensitivity adjustment

The sensitivity adjustment control can be used to compensate the differences between theoretical and real sensitivity. It is applied to all membranes of the microphone.

Sensitivity adjustment = [-4, 3.875) with a 0.125 dB step

Configuration registers: 0x5F(5-0), 0x60(5-0), 0x61(5-0)

3.6 Normal channel attenuation

The NORM_Att is a parameter which must be set to the sensitivity difference between the High SPL channel and the Normal SPL channel. By default its value is set to 20 dB.

Configuration registers: 0x52(5-0), 0x63(5-0), 0x64(5-0)

3.7 Thresholds

Two thresholds can be configured to control/select the recombination engine behavior. In particular, they can be used to give more weight (in the final output) to the Normal Channel or to the High Channel which leads to choosing between having lower distortion (High Channel) or lower noise floor (Normal Channel).

Configuration registers: 0x65(5-0), 0x66(5-0), 0x67(5-0), 0x68(5-0), 0x69(5-0), 0x6A(5-0)

4 I²C bus operation

The STA321MPL1 supports the I²C protocol via the input ports SCL and SDA_IN (master to slave) and the output port SDA_OUT (slave to master).

This protocol defines any device that sends data to the bus as a transmitter and any device that reads data as a receiver.

The device that controls the data transfer is known as the master and the other is the slave. The master always starts the transfer and provides the serial clock for synchronization. The STA321MPL1 is a slave device in all of its communications.

4.1 Communication protocol

4.1.1 Data transition or change

Data changes on the SDA line must only occur when the SCL clock is low. An SDA transition while the clock is high is used to identify a START or STOP condition.

4.1.2 Start condition

START is identified by a high-to-low transition of the data bus SDA signal while the clock signal SCL is stable in the high state. A START condition must precede any command for data transfer.

4.1.3 Stop condition

STOP is identified by a low-to-high transition of the data bus SDA signal while the clock signal SCL is stable in the high state. A STOP condition terminates communication between the STA321MPL1 and the bus master.

4.1.4 Data input

During data input, the STA321MPL1 samples the SDA signal on the rising edge of the clock SCL.

For correct device operation the SDA signal must be stable during the rising edge of the clock. The data can change only when the SCL line is low.

4.2 Device addressing

To start communication between the master and the Omega FFX core, the master must initiate with a start condition. Following this, the master sends 8 bits onto the SDA line (MSB first) corresponding to the device select address and read or write mode.

The 7 most significant bits are the device address identifiers, corresponding to the I²C bus definition. In the STA321MPL1 the I²C interface has two device addresses depending on the SA port configuration, 0x40 or 0100000x when SA = 0, and 0x42 or 0100001x when SA = 1.

The 8th bit (LSB) identifies a read or write operation RW. This bit is set to 1 in read mode and 0 for write mode. After a START condition, the STA321MPL1 identifies the device address on the bus and if a match is found, it acknowledges the identification on the SDA bus during the 9th-bit time. The byte following the device identification byte is the internal space address.

4.3 Write operation

Following a START condition, the master sends a device select code with the RW bit set to 0. The STA321MPL1 acknowledges this and then writes for the byte of the internal address.

After receiving the internal byte address, the STA321MPL1 responds again with an acknowledgement.

4.3.1 Byte write

In byte write mode, the master sends one data byte, this is acknowledged by the Omega FFX core. The master then terminates the transfer by generating a STOP condition.

4.3.2 Multi-byte write

The multi-byte write modes can start from any internal address. The master generating a STOP condition terminates the transfer.

Figure 6. Write mode sequence

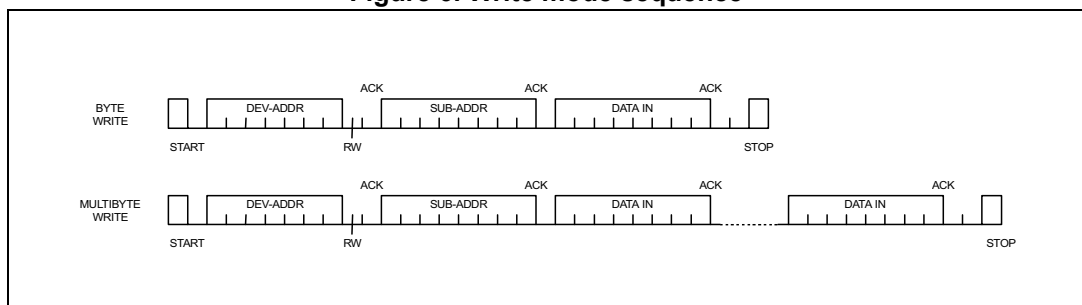

4.4 Read operation

4.4.1 Current address byte read

Following the START condition, the master sends a device select code with the RW bit set to 1. The STA321MPL1 acknowledges this and then responds by sending one byte of data. The master then terminates the transfer by generating a STOP condition.

4.4.2 Current address multi-byte read

The multi-byte read modes can start from any internal address. Sequential data bytes are read from sequential addresses within the STA321MPL1. The master acknowledges each data byte read and then generates a STOP condition, terminating the transfer.

4.4.3 Random address byte read

Following the START condition, the master sends a device select code with the RW bit set to 0. The STA321MPL1 acknowledges this and then the master writes the internal address byte. After receiving the internal byte address, the STA321MPL1 again responds with an acknowledgement. The master then initiates another START condition and sends the device select code with the RW bit set to 1. The STA321MPL1 acknowledges this and then responds by sending one byte of data. The master then terminates the transfer by generating a STOP condition.

4.4.4 Random address multi-byte read

The multi-byte read mode can start from any internal address. Sequential data bytes are read from sequential addresses within the STA321MPL1. The master acknowledges each data byte read and then generates a STOP condition, terminating the transfer.

Figure 7. Read mode sequence

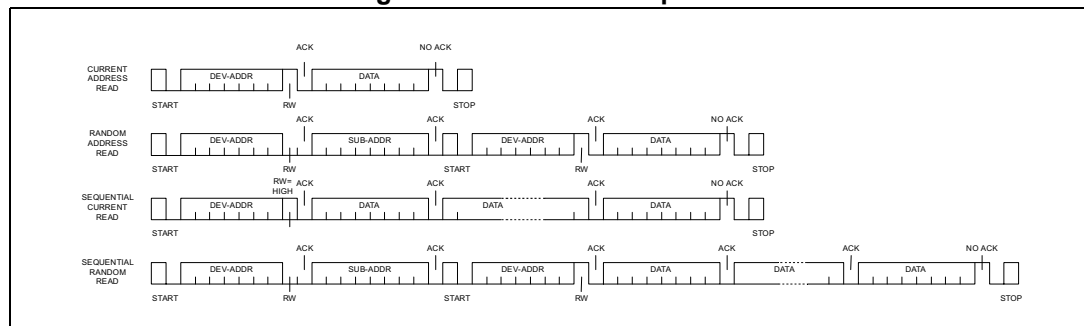

5 Registers

5.1 Register summary

Table 9. Register summary

Addr	Name	D7	D6	D5	D4	D3	D2	D1	D0
Configuration									
0x00	CONFA	COS1	COS0	DSPB	IR1	IR0	MCS2	MCS1	MCS0
0x01									
0x02	ConfC			SAOD4	SAOFB	SAO3	SAO2	SAO1	SAO0
0x03	ConfD	MPC	CSZ4	CSZ3	CSZ2	CSZ1	CSZ0	OM1	OM0
0x04	ConfE	C8BO	C7BO	C6BO	C5BO	C4BO	C3BO	C2BO	C1BO
0x05	ConfF	PWMS2	PWMS1	PWMS0	BQL	PSL	DEMP	DRC	HPB
0x06	ConfG	MPCV	DCCV	HPE	AM2E	AME	COD	SID	PWMD
0x07	ConfH	ECLE	LDTE	BCLE	IDE	ZDE	SVE	ZCE	NSBW
0x08	Confl	EAPD							PSCE
Volume control									
0x09	MMUTE								MMUTE
0x0A	Mvol	MV7	MV6	MV5	MV4	MV3	MV2	MV1	MV0
0x0B	C1Vol	C1V7	C1V6	C1V5	C1V4	C1V3	C1V2	C1V1	C1V0
0x0C	C2Vol	C2V7	C2V6	C2V5	C2V4	C2V3	C2V2	C2V1	C2V0
0x0D	C3Vol	C3V7	C3V6	C3V5	C3V4	C3V3	C3V2	C3V1	C3V0
0x0E	C4Vol	C4V7	C4V6	C4V5	C4V4	C4V3	C4V2	C4V1	C4V0
0x0F	C5Vol	C5V7	C5V6	C5V5	C5V4	C5V3	C5V2	C5V1	C5V0
0x10	C6Vol	C6V7	C6V6	C6V5	C6V4	C6V3	C6V2	C6V1	C6V0
0x11	C7Vol	C7V7	C7V6	C7V5	C7V4	C7V3	C7V2	C7V1	C7V0
0x12	C8Vol	C8V7	C8V6	C8V5	C8V4	C8V3	C8V2	C8V1	C8V0
0x13	C1VTMB	C1M	C1VBP		C1VT4	C1VT3	C1VT2	C1VT1	C1VT0
0x14	C2VTMB	C2M	C2VBP		C2VT4	C2VT3	C2VT2	C2VT1	C2VT0
0x15	C3VTMB	C3M	C3VBP		C3VT4	C3VT3	C3VT2	C3VT1	C3VT0
0x16	C4VTMB	C4M	C4VBP		C4VT4	C4VT3	C4VT2	C4VT1	C4VT0
0x17	C5VTMB	C5M	C5VBP		C5VT4	C5VT3	C5VT2	C5VT1	C5VT0
0x18	C6VTMB	C6M	C6VBP		C6VT4	C6VT3	C6VT2	C6VT1	C6VT0
0x19	C7VTMB	C7M	C7VBP		C7VT4	C7VT3	C7VT2	C7VT1	C7VT0
0x1A	C8VTMB	C8M	C8VBP		C8VT4	C8VT3	C8VT2	C8VT1	C8VT0

Table 9. Register summary (continued)

Addr	Name	D7	D6	D5	D4	D3	D2	D1	D0
Input mapping									
0x1B	C12im		C2IM2	C2IM1	C2IM0		C1IM2	C1IM1	C1IM0
0x1C	C34im		C4IM2	C4IM1	C4IM0		C3IM2	C3IM1	C3IM0
0x1D	C56im		C6IM2	C6IM1	C6IM0		C5IM2	C5IM1	C5IM0
0x1E	C78im		C8IM2	C8IM1	C8IM0		C7IM2	C7IM1	C7IM0
Processing loop									
0x28	BQlp	C8BLP	C7BLP	C6BLP	C5BLP	C4BLP	C3BLP	C2BLP	C1BLP
0x29	MXlp	C8MXLP	C7MXLP	C6MXLP	C5MXLP	C4MXLP	C3MXLP	C2MXLP	C1MXLP
Processing bypass									
0x2A	EQbp	C8EQBP	C7EQBP	C6EQBP	C5EQB	C4EQBP	C3EQBP	C2EQBP	C1EQBP
0x2B	ToneBP	C8TCB	C7TCB	C6TCB	C5TCB	C4TCB	C3TCB	C2TCB	C1TCB
Tone control									
0x2C	Tone	TTC3	TTC2	TTC1	TTC0	BTC3	BTC2	BTC1	BTC0
Dynamics control									
0x2D	C1234ls	C4LS1	C4LS0	C3LS1	C3LS0	C2LS1	C2LS0	C1LS1	C1LS0
0x2E	C5678ls	C8LS1	C8LS0	C7LS1	C7LS0	C6LS1	C6LS0	C5LS1	C5LS0
0x2F	L1ar	L1A3	L1A2	L1A1	L1A0	L1R3	L1R2	L1R1	L1R0
0x30	L1atrt	L1AT3	L1AT2	L1AT1	L1AT0	L1RT3	L1RT2	L1RT1	L1RT0
0x31	L2ar	L2A3	L2A2	L2A1	L2A0	L2R3	L2R2	L2R1	L2R0
0x32	L2atrt	L2AT3	L2AT2	L2AT1	L2AT0	L2RT3	L2RT2	L2RT1	L2RT0
PWM output timing									
0x33	C12ot		C2OT2	C2OT1	C2OT0		C1OT2	C1OT1	C1OT0
0x34	C34ot		C4OT2	C4OT1	C4OT0		C3OT2	C3OT1	C3OT0
0x35	C56ot		C6OT2	C6OT1	C6OT0		C5OT2	C5OT1	C5OT0
0x36	C78ot		C8OT2	C8OT1	C8OT0		C7OT2	C7OT1	C7OT0
I²S output channel mapping									
0x37	C12om		C2OM2	C2OM1	C2OM0		C1OM2	C1OM1	C1OM0
0x38	C34om		C4OM2	C4OM1	C4OM0		C3OM2	C3OM1	C3OM0
0x39	C56om		C6OM2	C6OM1	C6OM0		C5OM2	C5OM1	C5OM0
0x3A	C78om		C8OM2	C8OM1	C8OM0		C7OM2	C7OM1	C7OM0

Table 9. Register summary (continued)

Addr	Name	D7	D6	D5	D4	D3	D2	D1	D0
User-defined coefficient RAM									
0x3B	Cfaddr1							CFA9	CFA8
0x3C	Cfaddr2	CFA7	CFA6	CFA5	CFA4	CFA3	CFA2	CFA1	CFA0
0x3D	B1cf1	C1B23	C1B22	C1B21	C1B20	C1B19	C1B18	C1B17	C1B16
0x3E	B1cf2	C1B15	C1B14	C1B13	C1B12	C1B11	C1B10	C1B9	C1B8
0x3F	B1cf3	C1B7	C1B6	C1B5	C1B4	C1B3	C1B2	C1B1	C1B0
0x40	B2cf1	C2B23	C2B22	C2B21	C2B20	C2B19	C2B18	C2B17	C2B16
0x41	B2cf2	C2B15	C2B14	C2B13	C2B12	C2B11	C2B10	C2B9	C2B8
0x42	B2cf3	C2B7	C2B6	C2B5	C2B4	C2B3	C2B2	C2B1	C2B0
0x43	A1cf1	C3B23	C3B22	C3B21	C3B20	C3B19	C3B18	C3B17	C3B16
0x44	A1cf2	C3B15	C3B14	C3B13	C3B12	C3B11	C3B10	C3B9	C3B8
0x45	A1cf3	C3B7	C3B6	C3B5	C3B4	C3B3	C3B2	C3B1	C3B0
0x46	A2cf1	C4B23	C4B22	C4B21	C4B20	C4B19	C4B18	C4B17	C4B16
0x47	A2cf2	C4B15	C4B14	C4B13	C4B12	C4B11	C4B10	C4B9	C4B8
0x48	A2cf3	C4B7	C4B6	C4B5	C4B4	C4B3	C4B2	C4B1	C4B0
0x49	B0cf1	C5B23	C5B22	C5B21	C5B20	C5B19	C5B18	C5B17	C5B16
0x4A	B0cf2	C5B15	C5B14	C5B13	C5B12	C5B11	C5B10	C5B9	C5B8
0x4B	B0cf3	C5B7	C5B6	C5B5	C5B4	C5B3	C5B2	C5B1	C5B0
0x4C	Cfud							WA	W1
0x4D	MPCC1	MPCC15	MPCC14	MPCC13	MPCC12	MPCC11	MPCC10	MPCC9	MPCC8
0x4E	MPCC2	MPCC7	MPCC6	MPCC5	MPCC4	MPCC3	MPCC2	MPCC1	MPCC0
0x4F	DCC1	DCC15	DCC14	DCC13	DCC12	DCC11	DCC10	DCC9	DCC8
0x50	DCC2	DCC7	DCC6	DCC5	DCC4	DCC3	DCC2	DCC1	DCC0
0x51	PSC1	RCV11	RCV10	RCV9	RCV8	RCV7	RCV6	RCV5	RCV4
0x52	PSC2	RCV3	RCV2	RCV1	RCV0	CNV11	CNV10	CNV9	CNV8
0x53	PSC3	CNV7	CNV6	CNV5	CNV4	CNV3	CNV2	CNV1	CNV0
BIST									
0x57	BACT	R8BACT	R7BACT	R6BACT	R5BACT	R4BACT	R3BACT	R2BACT	R1BCAT
0x58	BEND	R8BEND	R7BEND	R6BEND	R5BEND	R4BEND	R3BEND	R2BEND	R1BEND
0x59	BBAD	R8BBAD	R7BBAD	R6BBAD	R5BBAD	R4BBAD	R3BBAD	R2BBAD	R1BBAD
0x5A	L12new								NLENAR
0x5B	FineVol	CFINE8	CFINE7	CFINE6	CFINE5	CFINE4	CFINE3	CFINE2	CFINE1

Table 9. Register summary (continued)

Addr	Name	D7	D6	D5	D4	D3	D2	D1	D0
PDM and recombination IP interface									
0x5C	MRBist	MHFail	MHBad	MHEnd	MHAct	MNFail	MNBad	MNEnd	MNAct
0x5D	RCTR1	Boost6db			I ² S_byp	I ² S_en	mike_en	mike_byp	m_mode
0x5E	PDMCT	AdvM6	AdvM5	AdvM4	AdvM3	AdvM2	AdvM1	PDMSM[1:0]	
0x5F	RCTR2		bypRM1	CH1GG[5:0]					
0x60	RCTR3		bypRM2	CH2GG[5:0]					
0x61	RCTR4		bypRM3	CH3GG[5:0]					
0x62	RCTR5		LP1en	CH1NCA[5:0]					
0x63	RCTR6		LP2en	CH2NCA[5:0]					
0x64	RCTR7		LP3en	CH3NCA[5:0]					
0x65	RCTR8			CH1TH_N[5:0]					
0x66	RCTR9			CH2TH_N[5:0]					
0x67	RCTR10			CH3TH_N[5:0]					
0x68	RCTR11			CH1TH_H[5:0]					
0x69	RCTR12			CH2TH_H[5:0]					
0x6A	RCTR13			CH3TH_H[5:0]					
Clock manager configuration/status registers									
0x71	pllfrac1	PLFI15	PLFI14	PLFI13	PLFI12	PLFI11	PLFI10	PLFI9	PLFI8
0x72	pllfrac0	PLFI7	PLFI6	PLFI5	PLFI4	PLFI3	PLFI2	PLFI1	PLFI0
0x73	pll div	PLLDD1	PLLDD0	PLLND5	PLLND4	PLLND3	PLLND2	PLLND1	PLLND0
0x74	pll conf0	PDPDC	PLLFC	PLSTRB	PLSTBB	PLIFD3	PLIFD2	PLIFD1	PLIFD0
0x75	pll conf1					PLLBYD	PLLDPR	LOWEN	BST32K
0x76	pll stat					PLLBYD	PLLPDS	OSCOK	LOWCKS
Biquad configuration									
0x77	CBQ1	EBQ3_1	EBQ3_0	EBQ2_1	EBQ2_0	EBQ1_1	EBQ1_0	EBQ0_0	EBQ0_0
0x78	CBQ2	EBQ7_1	EBQ7_0	EBQ6_1	EBQ6_0	EBQ5_1	EBQ5_0	EBQ4_0	EBQ4_0
0x79	CBQ3				nshen	EBQ9_1	EBQ9_0	EBQ8_0	EBQ8_0
RMS status registers									
0x7A	rmsZMH	RZM15	RZM14	RZM13	RZM12	RZM11	RZM10	RZM9	RZM8
0x7B	rmsZML	RZM7	RZM6	RZM5	RZM4	RZM3	RZM2	RZM1	RZM0
0x7C	rmsPOH	RPO15	RPO14	RPO13	RPO12	RPO11	RPO10	RPO9	RPO8
0x7D	rmsPOL	RPO7	RPO6	RPO5	RPO4	RPO3	RPO2	RPO1	RPO0
Tristate startup/shutdown pop removal signals									
0x80	DPT				DPT4	DPT3	DPT2	DPT1	DPT0
0x81	CFR129	RL3	RL2	RL1	RL0	RD	SID1	FBYP	RTP
0x82	TSDLY1	UDDT15	UDDT14	UDDT13	UDDT12	UDDT11	UDDT10	UDDT9	UDDT8
0x83	TSDLY2	UDDT7	UDDT6	UDDT5	UDDT4	UDDT3	UDDT2	UDDT1	UDDT0

5.2 Register description

5.2.1 Configuration register A (0x00)

D7	D6	D5	D4	D3	D2	D1	D0
COS1	COS0	DSPB	IR1	IR0	MCS2	MCS1	MCS0
1	0	0	1	1	0	1	1

Bit	RW	RST	Name	Description
0	RW	1	MCS0	Master clock select: selects the ratio between the input sampling frequency (PDM I/FCLK) and the input clock (XTI).
1	RW	1	MCS1	
2	RW	0	MCS2	

- The internal clock depends on the external clock frequency provided to the XTI pin. The internal clock can be either 90.3168 MHz or 98.304 MHz. In the case of the XTI, it is respectively 11.2896MHz or 12.288MHz.
- The relationship between the input clock XTI and the PDM interface clock is determined by both the MCSn and the IRn (input rate) register bits. IR[1,0] = 11 sets the PDM interface enable and MCS[2:0] = 011 means XTI = 4*PDM interface clock.

If XTI input is not used, the related pin must be tied to GND.

Input sampling rate <i>f_s</i> (kHz)	IR	MCS[2:0]				
		1xx	011	010	001	000
XTI	11	2*PDM_CK	4*PDM_CK	6*PDM_CK	8*PDM_CK	12*PDM_CK

Interpolation ratio select

Bit	RW	RST	Name	Description
0	RW	0	DSPB	DSP bypass bit: 0: normal operation 1: bypass of biquad and bass/treble functions

Setting the DSPB bit bypasses the biquad function of the FFX core.

COS [1,0]	CKOUT frequency
00	PLL output
01	PLL output / 4
10	PLL output / 8
11	PLL output / 16

cos [1,0] sets the clock out value. Clock out frequency is a ratio of the internal clock and the ratio depends on the cos[1,0] setting.

Example cos[1,0] = 10:

$XTI = 12.288$

PLL output = 98.304 MHz

$CK_out = 98.304/8 = 12.288$

Clock out is automatically configured to obtain a frequency of 64 Fs (sys_clock/32) if the bit0 of the register 0x5D is asserted. This generates a valid clock to be provided to a digital (PDM) microphone.

5.2.2 Configuration register C (0x02) - serial output formats

D7	D6	D5	D4	D3	D2	D1	D0
		SAOD4	SAOFB	SAO3	SAO2	SAO1	SAO0
		0	0	0	0	0	0

Bit	RW	RST	Name	Description
0	RW	0	SAO0	Serial audio output interface format: determines the interface format of the output serial digital audio interface.
1	RW	0	SAO1	
2	RW	0	SAO2	
3	RW	0	SAO3	

The STA321MPL1 features a serial audio output interface that consists of 8 channels. The serial audio output always acts as a slave to the serial audio input interface and, therefore, all output clocks are synchronous with the input clocks. The output sampling frequency (fs) is also equivalent to the input sampling frequency. In the case of the PDM input, the serial audio output acts as a master with an output sampling frequency of 8 xfs, 4 xfs or fs depending on the SAOD4 bit. The output serial format can be selected independently from the input format and is done via the SAO and SAOFB bits.

Bit	RW	RST	Name	Description
4	RW	0	SAOFB	Determines MSB or LSB first for all SAO formats: 0: MSB first 1: LSB first

Bit	RW	RST	Name	Description
5	RW	0	SAOD4	Enables decimation by 4 on SAO interface for PDM input; no effect for others. 0: div by 1 1: div by 4 ⁽¹⁾

1. To avoid any aliasing on SAO streaming, a low-pass filter needs to be implemented in one of the available user-programmable biquads.

Table 10. Serial audio output formats according to sampling rate

BICKO	SAO[3:0]	Interface data format
32 * fs	0111	I ² S data
	1111	Left/right-justified 16-bit data
48 * fs	1110	I ² S data
	0001	Left-justified data
	1010	Right-justified 24-bit data
	1011	Right-justified 20-bit data
	1100	Right-justified 18-bit data
	1101	Right-justified 16-bit data
64 * fs	0000	I ² S data
	0001	Left-justified data
	0010	Right-justified 24-bit data
	0011	Right-justified 20-bit data
	0100	Right-justified 18-bit data
	0101	Right-justified 16-bit data

5.2.3 Configuration register D (0x03)

D7	D6	D5	D4	D3	D2	D1	D0
MPC	CSZ4	CSZ3	CSZ2	CSZ1	CSZ0	OM1	OM0
1	1	1	1	1	1	1	0

Bit	RW	RST	Name	Description
0	RW	0	OM0	FFX power output mode: selects configuration of FFX output
1	RW	1	OM1	

The FFX power output mode selects how the FFX output timing is configured. Different power devices use different output modes.

Bit	RW	RST	Name	Description
2	RW	1	CSZ0	Contra size register: when OM[1,0] = 11, this register determines the size of the FFX compensating pulse from 0 clock ticks to 31 clock periods
3	RW	1	CSZ1	
4	RW	1	CSZ2	
5	RW	1	CSZ3	
6	RW	1	CSZ4	

CSZ[4:0]	Compensating pulse size
00000	0 clock period compensating pulse size
00001	1 clock period compensating pulse size
...	...
11111	31 clock period compensating pulse size

5.2.4 Configuration register E (0x04)

D7	D6	D5	D4	D3	D2	D1	D0
C8BO	C7BO	C6BO	C5BO	C4BO	C3BO	C2BO	C1BO
0	0	0	0	0	0	0	0

Bit	RW	RST	Name	Description
0	RW	0	C1BO	Channels 1, 2, 3, 4, 5, 6, 7, and 8 binary output mode enable bits. A setting of 0 indicates ordinary FFX tristate output. A setting of 1 indicates binary output mode.
1	RW	0	C2BO	
2	RW	0	C3BO	
3	RW	0	C4BO	
4	RW	0	C5BO	
5	RW	0	C6BO	
6	RW	0	C7BO	
7	RW	0	C8BO	

Each individual channel output can be set to output a binary PWM stream. In this mode, output A of a channel is considered the positive output and output B the negative output.

5.2.5 Configuration register F (0x05)

D7	D6	D5	D4	D3	D2	D1	D0
PWMS2	PWMS1	PWMS0	BQL	PSL	DEMP	DRC	HPB
0	0	0	0	0	0	0	0

Bit	RW	RST	Name	Description
0	RW	0	HPB	High-pass filter bypass bit: a setting of 1 bypasses internal AC coupling digital high-pass filter

The STA321MPL1 features an internal digital high-pass filter for the purpose of AC coupling. The purpose of this filter is to prevent DC signals from passing through an FFX amplifier. DC signals can cause speaker damage.

If HPB = 1, then the filter that the high-pass filter utilizes is made available as a user-programmable biquad #1.

Bit	RW	RST	Name	Description
1	RW	0	DRC	Dynamic range compression/anti-clipping 0: limiters act in anti-clipping mode 1: limiters act in dynamic range compression mode

Both limiters can be used in one of two ways, anti-clipping or dynamic range compression. When used in anti-clipping mode, the limiter threshold values are constant and dependent on the limiter settings.

In dynamic range compression mode, the limiter threshold values vary with the volume settings allowing a nighttime listening mode that provides a reduction in the dynamic range regardless of the volume level.

Bit	RW	RST	Name	Description
2	RW	0	DEMP	De-emphasis: 0: no de-emphasis 1: de-emphasis

By setting this bit to 1, de-emphasis are implemented on all channels. When this is used it takes the place of biquad #7 in each channel and any coefficients using biquad #1 is ignored. The DSPB (DSP bypass) bit must be set to 0 for de-emphasis to function.

Bit	RW	RST	Name	Description
3	RW	0	PSL	Post-scale link: 0: each channel uses individual post-scale value 1: each channel uses channel 1 post-scale value

Post-scale functionality can be used for power-supply error correction. For multi-channel applications running off the same power-supply, the post-scale values can be linked to the value of channel 1 for ease of use and to update the values faster.

Bit	RW	RST	Name	Description
4	RW	0	BQL	Biquad link: 0: each channel uses coefficient values 1: each channel uses channel 1 coefficient values

For ease of use, all channels can use the biquad coefficients loaded into the channel 1 coefficient RAM space by setting the BQL bit to 1. Therefore, any EQ updates only have to be performed once.

Bit	RW	RST	Name	Description
7:5	RW	00	PWMS[2:0]	PWM speed selection

PWMS[1:0]	PWM output speed
000	Normal speed (384 kHz) (all channels)
001	Half-speed (192 kHz) (all channels)
010	Double-speed (768 kHz) (all channels)
011	Normal speed (channels 1-6), double-speed (channels 7-8)
100	Odd speed (341.3 kHz) (all channels)

5.2.6 Configuration register G (0x06)

D7	D6	D5	D4	D3	D2	D1	D0
MPCV	DCCV	HPE	AM2E	AME	COD	SID	PWMD
0	0	0	0	0	0	0	0

Bit	RW	RST	Name	Description
0	RW	0	PWMD	PWM output disable: 0: PWM output normal 1: no PWM output
1	RW	0	SID	Serial interface (I ² S out) disable: 0: I ² S output normal 1: no I ² S output
2	RW	0	COD	Clock output disable: 0: clock output normal 1: no clock output

Bit	RW	RST	Name	Description
3	RW	0	AME	AM mode enable: 0: normal FFX operation 1: AM reduction mode FFX operation

The STA321MPL1 features an FFX processing mode that minimizes the amount of noise generated in the frequency range of AM radio. This mode is intended for use when FFX is operating in a device with an active AM tuner. The SNR of the FFX processing is reduced to ~83 dB in this mode, which is still greater than the SNR of AM radio.

Bit	RW	RST	Name	Description
4	RW	0	AM2E	AM2 mode enable: 0: normal FFX operation 1: AM2 reduction mode FFX operation

The STA321MPL1 features two FFX processing modes that minimize the amount of noise generated in the frequency range of AM radio. This second mode is intended for use when FFX is operating in a device with an active AM tuner. This mode eliminates the noise-shaper.

Bit	RW	RST	Name	Description
5	RW	0	HPE	FFX headphone enable: 0: channels 7 and 8 normal FFX operation 1: channels 7 and 8 headphone operation

Channels 7 and 8 can be configured to be processed and output in such a manner that headphones can be driven using an appropriate output device. This signal is a differential 3-wire drive called FFX headphone.

Bit	RW	RST	Name	Description
6	RW	0	DCCV	Distortion compensation variable enable: 0: uses the preset DC coefficient 1: uses the DCC coefficient

Bit	RW	RST	Name	Description
7	RW	0	MPCV	Max power correction variable: 0: uses the standard MPC coefficient 1: uses the MPCC bits for the MPC coefficient

5.2.7 Configuration register H (0x07)

D7	D6	D5	D4	D3	D2	D1	D0
ECLE	LDTE	BCLE	IDE	ZDE	SVE	ZCE	NSBW
0	1	1	1	1	1	1	0

Bit	RW	RST	Name	Description
0	RW	0	NSBW	Noise-shaper bandwidth selection: 1: 3 rd order NS 0: 4 th order NS

Bit	RW	RST	Name	Description
1	RW	1	ZCE	Zero-crossing volume enable: 1: volume adjustments only occur at digital zero-crossings 0: volume adjustments occur immediately

The ZCE bit enables zero-crossing volume adjustments. When volume is adjusted on digital zero-crossings, no clicks are audible.

Bit	RW	RST	Name	Description
2	RW	1	SVE	Soft volume enable: 1: volume adjustments use soft volume 0: volume adjustments occur immediately

Bit	RW	RST	Name	Description
3	RW	1	ZDE	Zero-detect mute enable: a setting of 1 enables the automatic zero-detect mute

Setting the ZDE bit enables the zero-detect automatic mute. See [Section 6.5.8](#) for more details.

Bit	RW	RST	Name	Description
4	RW	1	IDE	Invalid input detect mute enable: 1: enable the automatic invalid input detect mute

Setting the IDE bit enables this function, which looks at the input I²S data and automatically mutes if the signals are perceived as invalid.

Bit	RW	RST	Name	Description
5	RW	1	BCLE	Binary output mode clock loss detection enable

The BCLE bit detects loss of input, MCLK, in binary mode and outputs a 50 % duty cycle.

Bit	RW	RST	Name	Description
6	RW	1	LDTE	LRCLK double trigger protection enable

The LDTE bit actively prevents double triggering of LRCLK.

Bit	RW	RST	Name	Description
7	RW	0	ECLE	Auto EAPD on clock loss

When active, the ECLE bit issues a device power-down signal (EAPD) on clock loss detection.

5.2.8 Configuration register I (0x08)

D7	D6	D5	D4	D3	D2	D1	D0
EAPD							PSCE
0							0

This feature utilizes an ADC on SDI78 that provides power supply ripple information for correction. Registers PSC1, PSC2, PSC3 are utilized in this mode.

Bit	RW	RST	Name	Description
0	RW	0	PSCE	Power supply ripple correction enable: 0: normal operation 1: PSCorrect operation

Bit	RW	RST	Name	Description
7	RW	0	EAPD	External amplifier power-down: 0: external power stage power-down active 1: normal operation

5.2.9 Master mute register (0x09)

D7	D6	D5	D4	D3	D2	D1	D0
							MMUTE
							0

5.2.10 Master volume register (0x0A)

D7	D6	D5	D4	D3	D2	D1	D0
MV7	MV6	MV5	MV4	MV3	MV2	MV1	MV0
1	1	1	1	1	1	1	1

Note: The value of the volume derived from MVOL is dependent on the AMV AutoMode volume settings.

5.2.11 Channel 1 volume (0x0B)

D7	D6	D5	D4	D3	D2	D1	D0
C1V7	C1V6	C1V5	C1V4	C1V3	C1V2	C1V1	C1V0
0	1	1	0	0	0	0	0

5.2.12 Channel 2 volume (0x0C)

D7	D6	D5	D4	D3	D2	D1	D0
C2V7	C2V6	C2V5	C2V4	C2V3	C2V2	C2V1	C2V0
0	1	1	0	0	0	0	0

5.2.13 Channel 3 volume (0x0D)

D7	D6	D5	D4	D3	D2	D1	D0
C3V7	C3V6	C3V5	C3V4	C3V3	C3V2	C3V1	C3V0
0	1	1	0	0	0	0	0

5.2.14 Channel 4 volume (0x0E)

D7	D6	D5	D4	D3	D2	D1	D0
C4V7	C4V6	C4V5	C4V4	C4V3	C4V2	C4V1	C4V0
0	1	1	0	0	0	0	0

5.2.15 Channel 5 volume (0x0F)

D7	D6	D5	D4	D3	D2	D1	D0
C5V7	C5V6	C5V5	C5V4	C5V3	C5V2	C5V1	C5V0
0	1	1	0	0	0	0	0

5.2.16 Channel 6 volume (0x10)

D7	D6	D5	D4	D3	D2	D1	D0
C6V7	C6V6	C6V5	C6V4	C6V3	C6V2	C6V1	C6V0
0	1	1	0	0	0	0	0

5.2.17 Channel 7 volume (0x11)

D7	D6	D5	D4	D3	D2	D1	D0
C7V7	C7V6	C7V5	C7V4	C7V3	C7V2	C7V1	C7V0
0	1	1	0	0	0	0	0

5.2.18 Channel 8 volume (0x12)

D7	D6	D5	D4	D3	D2	D1	D0
C8V7	C8V6	C8V5	C8V4	C8V3	C8V2	C8V1	C8V0
0	1	1	0	0	0	0	0

5.2.19 Channel 1 volume trim, mute, bypass (0x13)

D7	D6	D5	D4	D3	D2	D1	D0
C1M	C1VBP		C1VT4	C1VT3	C1VT2	C1VT1	C1VT0
0	0	0	1	0	0	0	0

5.2.20 Channel 2 volume trim, mute, bypass (0x14)

D7	D6	D5	D4	D3	D2	D1	D0
C2M	C2VBP		C2VT4	C2VT3	C2VT2	C2VT1	C2VT0
0	0	0	1	0	0	0	0

5.2.21 Channel 3 volume trim, mute, bypass (0x15)

D7	D6	D5	D4	D3	D2	D1	D0
C3M	C3VBP		C3VT4	C3VT3	C3VT2	C3VT1	C3VT0
0	0	0	1	0	0	0	0

5.2.22 Channel 4 volume trim, mute, bypass (0x16)

D7	D6	D5	D4	D3	D2	D1	D0
C4M	C4VBP		C4VT4	C4VT3	C4VT2	C4VT1	C4VT0
0	0	0	1	0	0	0	0

5.2.23 Channel 5 volume trim, mute, bypass (0x17)

D7	D6	D5	D4	D3	D2	D1	D0
C5M	C5VBP		C5VT4	C5VT3	C5VT2	C5VT1	C5VT0
0	0	0	1	0	0	0	0

5.2.24 Channel 6 volume trim, mute, bypass (0x18)

D7	D6	D5	D4	D3	D2	D1	D0
C6M	C6VBP		C6VT4	C6VT3	C6VT2	C6VT1	C6VT0
0	0	0	1	0	0	0	0

5.2.25 Channel 7 volume trim, mute, bypass (0x19)

D7	D6	D5	D4	D3	D2	D1	D0
C7M	C7VBP		C7VT4	C7VT3	C7VT2	C7VT1	C7VT0
0	0	0	1	0	0	0	0

5.2.26 Channel 8 volume trim, mute, bypass (0x1A)

D7	D6	D5	D4	D3	D2	D1	D0
C8M	C8VBP		C8VT4	C8VT3	C8VT2	C8VT1	C8VT0
0	0	0	1	0	0	0	0

5.2.27 Fine volume (FineVol) (0x5B)

D7	D6	D5	D4	D3	D2	D1	D0
CFINE8	CFINE7	CFINE6	CFINE5	CFINE4	CFINE3	CFINE2	CFINE1
0	0	0	0	0	0	0	0

Bit	RW	RST	Name	Description
0-7	RW	0	CFINEx	Set for each channel, a fine volume of -0.25 dB, this value has to be added to the whole volume. 0: fine vol off 1: fine vol on

The volume structure of the STA321MPL1 consists of individual volume registers for each channel and a master volume register that provides an offset to each channel's volume setting. There is also an additional offset for each channel called channel volume trim. The individual channel volumes are adjustable in 0.5 dB steps from 48 dB to -78 dB. As an example, if C5V = 0xXX or +XXX dB and MV = 0xXX or -XX dB, then the total gain for channel 5 = XX dB. The channel volume trim is adjustable independently on each channel from -10 dB to 10 dB in 1 dB steps. A fine volume configuration register could be used to offset each channel at 0.25 dB step.

The master mute when set to 1 mutes all channels at once, whereas the individual channel mutes (CnM) mutes only that channel. Both the master mute and the channel mutes provide a "soft mute" with the volume ramping down to mute in 8192 samples from the maximum volume setting at the internal processing rate (~192 kHz). A "hard mute" can be obtained by commanding a value of 0xFF (255) to any channel volume register or the master volume register. When volume offsets are provided via the master volume register any channel whose total volume is less than -91 dB is muted. All changes in volume take place at zero-crossings when ZCE = 1 (configuration register H) on a per-channel basis as this creates the smoothest possible volume transitions. When ZCE = 0, volume updates occur immediately. Each channel also contains an individual channel volume bypass. If a particular channel has volume bypassed via the CnVBP = 1 register, then only the channel volume setting for that particular channel affects the volume setting, the master volume setting does not affect that channel. Each channel also contains a channel mute. If CnM = 1, a soft mute is performed on that channel.

MV[7:0]	Volume offset from channel value
0x00	0 dB
0x01	-0.5 dB
0x02	-1 dB
...	...
0x4C	-38 dB
...	...
0xFE	-127 dB
0xFF	Hardware channel mute

CnV[7:0]	Volume
0x00	48 dB
0x01	47.5 dB
0x02	47 dB
...	...
0x5F	0.5 dB
0x60	0 dB
0x61	-0.5 dB
...	...
0xFE	-79.5 dB
0xFF	Hardware channel mute

CnVT[4:0]	Volume
0x00 to 0x06	10 dB
0x07	9 dB
...	...
0x0F	1 dB
0x10	0 dB
0x11	-1 dB
...	...
0x19	-9 dB
0x1A to 0x1F	-10 dB

5.2.28 Channel input mapping channels 1 and 2 (0x1B)

D7	D6	D5	D4	D3	D2	D1	D0
	C2IM2	C2IM1	C2IM0		C1IM2	C1IM1	C1IM0
	0	0	1		0	0	0

5.2.29 Channel input mapping channels 3 and 4 (0x1C)

D7	D6	D5	D4	D3	D2	D1	D0
	C4IM2	C4IM1	C4IM0		C3IM2	C3IM1	C3IM0
	0	1	1		0	1	0

5.2.30 Channel input mapping channels 5 and 6 (0x1D)

D7	D6	D5	D4	D3	D2	D1	D0
	C6IM2	C6IM1	C6IM0		C5IM2	C5IM1	C5IM0
	1	0	1		1	0	0

5.2.31 Channel input mapping channels 7 and 8 (0x1E)

D7	D6	D5	D4	D3	D2	D1	D0
	C8IM2	C8M1	C8IM0		C7IM2	C7IM1	C7IM0
	1	1	1		1	1	0

Each channel received via the I²S can be mapped to any internal processing channel via the channel input mapping registers. This allows for flexibility in processing, simplifies output stage designs, and enables the ability to perform crossovers. The default settings of these registers map each I²S input channel to its corresponding processing channel.

CnIM[2:0]	Serial input from
000	Channel 1
001	Channel 2
010	Channel 3
011	Channel 4
100	Channel 5
101	Channel 6
110	Channel 7
111	Channel 8

5.2.32 AGEQ - graphic EQ 80-Hz band (0x23)

D7	D6	D5	D4	D3	D2	D1	D0
			AGEQ4	AGEQ3	AGEQ2	AGEQ1	AGEQ0
			0	1	1	1	1

5.2.33 BGEQ - graphic EQ 300-Hz band (0x24)

D7	D6	D5	D4	D3	D2	D1	D0
			BGEQ4	BGEQ3	BGEQ2	BGEQ1	BGEQ0
			0	1	1	1	1

5.2.34 CGEQ - graphic EQ 1-kHz band (0x25)

D7	D6	D5	D4	D3	D2	D1	D0
			CGEQ4	CGEQ3	CGEQ2	CGEQ1	CGEQ0
			0	1	1	1	1

5.2.35 DGEQ - graphic EQ 3-kHz band (0x26)

D7	D6	D5	D4	D3	D2	D1	D0
			DGEQ4	DGEQ3	DGEQ2	DGEQ1	DGEQ0
			0	1	1	1	1

5.2.36 EGEQ - graphic EQ 8-kHz band (0x27)

D7	D6	D5	D4	D3	D2	D1	D0
			EGEQ4	EGEQ3	EGEQ2	EGEQ1	EGEQ0
			0	1	1	1	1

xGEQ[4:0]	Boost / cut
11111	16
11110	15
11101	14
...	...
10000	1
01111	0
01110	-1
...	...
00001	-14
00000	-15

5.2.37 Biquad internal channel loop-through (0x28)

D7	D6	D5	D4	D3	D2	D1	D0
C8BLP	C7BLP	C6BLP	C5BLP	C4BLP	C3BLP	C2BLP	C1BLP
0	0	0	0	0	0	0	0

Each internal processing channel can receive two possible inputs at the input to the biquad block. The input can come either from the output of that channel's MIX#1 engine or from the output of the bass/treble (biquad #10) of the previous channel. In this scenario, channel 1 receives channel 8. This enables the use of more than 10 biquads on any given channel at the loss of the number of separate internal processing channels.

Bit	RW	RST	Name	Description
7:0	RW	0	CnBLP	For n = 1 to 8: 0: input from channel n MIX#1 engine output - normal operation 1: input from channel (n - 1) biquad #10 output - loop operation.

5.2.38 Mix internal channel loop-through (0x29)

D7	D6	D5	D4	D3	D2	D1	D0
C8MXLP	C7MXLP	C6MXLP	C5MXLP	C4MXLP	C3MXLP	C2MXLP	C1MXLP
0	0	0	0	0	0	0	0

Each internal processing channel can receive two possible sets of inputs at the input to the Mix#1 block. The inputs can come from the outputs of the interpolation block as normally occurs (CnMXLP = 0) or they can come from the outputs of the Mix#2 block. This enables the use of additional filtering after the second mix block at the expense of losing this processing capability on the channel.

Bit	RW	RST	Name	Description
7:0	RW	0	CnMXLP	For n = 1 to 8: 0: inputs to channel n MIX#1 engine from interpolation outputs - normal operation 1: inputs to channel n MIX#1 engine from MIX#2 engine outputs - loop operation

5.2.39 EQ bypass (0x2A)

D7	D6	D5	D4	D3	D2	D1	D0
C8EQBP	C7EQBP	C6EQBP	C5EQBP	C4EQCBP	C3EQBP	C2EQBP	C1EQBP
0	0	0	0	0	0	0	0

EQ control can be bypassed on a per-channel basis. If EQ control is bypassed on a given channel, the prescale and all 10 filters (high-pass, biquads, de-emphasis, bass management cross-over, bass, treble in any combination) are bypassed for that channel.

Bit	RW	RST	Name	Description
7:0	RW	0	CnEQBP	For n = 1 to 8: 0: perform EQ on channel n - normal operation 1: bypass EQ on channel n

5.2.40 Tone control bypass (0x2B)

D7	D6	D5	D4	D3	D2	D1	D0
C8TCB	C7TCB	C6TCB	C5TCB	C4TCB	C3TCB	C2TCB	C1TCB
0	0	0	0	0	0	0	0

Tone control (bass/treble) can be bypassed on a per-channel basis. If tone control is bypassed on a given channel, the two filters that tone control utilizes are made available as user-programmable biquads #9 and #10.

5.2.41 Tone control (0x2C)

D7	D6	D5	D4	D3	D2	D1	D0
TTC3	TTC2	TTC1	TTC0	BTC3	BTC2	BTC1	BTC0
0	1	1	1	0	1	1	1

This is the tone control boost/cut as a function of the BTC and TTC bits.

BTC[3:0] / TTC[3:0]	Boost / cut
0000	-12 dB
0001	-12 dB
...	...
0111	-4 dB
0110	-2 dB
0111	0 dB
1000	2 dB
1001	4 dB
...	...
1101	12 dB
1110	12 dB
1111	12dB

5.2.42 Channel limiter select channels 1, 2, 3, 4 (0x2D)

D7	D6	D5	D4	D3	D2	D1	D0
C4LS1	C4LS0	C3LS1	C3LS0	C2LS1	C2LS0	C1LS1	C1LS0
0	0	0	0	0	0	0	0

5.2.43 Channel limiter select channels 5, 6, 7, 8 (0x2E)

D7	D6	D5	D4	D3	D2	D1	D0
C8LS1	C8LS0	C7LS1	C7LS0	C6LS1	C6LS0	C5LS1	C5LS0
0	0	0	0	0	0	0	0

5.2.44 Limiter 1 attack/release rate (0x2F)

D7	D6	D5	D4	D3	D2	D1	D0
L1A3	L1A2	L1A1	L1A0	L1R3	L1R2	L1R1	L1R0
0	1	1	0	1	0	1	0

5.2.45 Limiter 1 attack/release threshold (0x30)

D7	D6	D5	D4	D3	D2	D1	D0
L1AT3	L1AT2	L1AT1	L1AT0	L1RT3	L1RT2	L1RT1	L1RT0
0	1	1	0	1	0	0	1

5.2.46 Limiter 2 attack/release rate (0x31)

D7	D6	D5	D4	D3	D2	D1	D0
L2A3	L2A2	L2A1	L2A0	L2R3	L2R2	L2R1	L2R0
0	1	1	0	1	0	1	0

5.2.47 Limiter 2 attack/release threshold (0x32)

D7	D6	D5	D4	D3	D2	D1	D0
L2AT3	L2AT2	L2AT1	L2AT0	L2RT3	L2RT2	L2RT1	L2RT0
0	1	1	0	1	0	0	1

5.2.48 Limiter description

The STA321MPL1 includes two independent limiter blocks. The purpose of the limiters is to automatically reduce the dynamic range of a recording to prevent the outputs from clipping in anti-clipping mode or to actively reduce the dynamic range for a better listening environment such as a nighttime listening mode which is often needed for DVDs. The two modes are selected via the DRC bit in configuration register B, bit 7 address 0x02. Each channel can be mapped to either limiter or not mapped, meaning that the channel clips when 0 dBFS is exceeded. Each limiter looks at the present value of each channel that is mapped to it, selects the maximum absolute value of all these channels, performs the limiting algorithm on that value, and then, if needed, adjusts the gain of the mapped channels in unison.

The limiter attack thresholds are determined by the LnAT registers. It is recommended in anti-clipping mode to set this to 0 dBFS, which corresponds to the maximum unclipped output power of an FFX amplifier. Since gain can be added digitally within the STA321MPL1 it is possible to exceed 0 dBFS or any other LnAT setting. When this occurs, the limiter, when active, automatically starts reducing the gain. The rate at which the gain is reduced when the attack threshold is exceeded is dependent upon the attack rate register setting for that limiter. The gain reduction occurs on a peak-detect algorithm.

The release of the limiter, when the gain is again increased, is dependent on an RMS-detect algorithm. The output of the volume/limiter block is passed through an RMS filter. The output of this filter is compared to the release threshold, determined by the release threshold register. When the RMS filter output falls below the release threshold, the gain is again increased at a rate dependent upon the release rate register. The gain can never be increased past its set value and therefore the release only occurs if the limiter has already reduced the gain. The release threshold value can be used to set what is effectively a minimum dynamic range, this is helpful as overlimiting can reduce the dynamic range to virtually zero and cause program material to sound lifeless.

In AC mode, the attack and release thresholds are set relative to full-scale. In DRC mode, the attack threshold is set relative to the maximum volume setting of the channels mapped to that limiter and the release threshold is set relative to the maximum volume setting plus the attack threshold.

Figure 8. Basic limiter and volume flow diagram

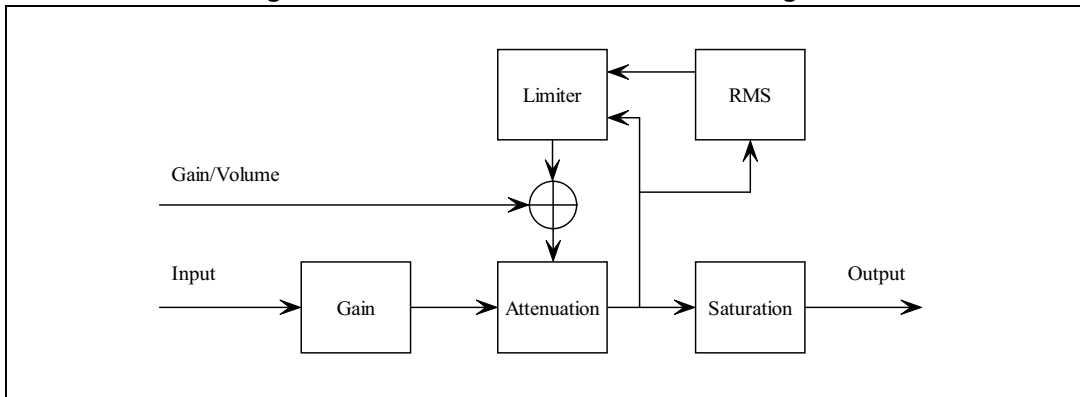

CnLS[1,0]	Channel limiter mapping
00	Channel has limiting disabled
01	Channel is mapped to limiter #1
10	Channel is mapped to limiter #2

LnA[3:0]	Attack rate (dB/ms)
0000	3.1584 (fast)
0001	2.7072
0010	2.2560
0011	1.8048
0100	1.3536
0101	0.9024
0110	0.4512
0111	0.2256
1000	0.1504
1001	0.1123
1010	0.0902
1011	0.0752
1100	0.0645
1101	0.0564
1110	0.0501
1111	0.0451 (slow)

LnR[3:0]	Release rate (dB/ms)
0000	0.5116 (fast)
0001	0.1370
0010	0.0744
0011	0.0499
0100	0.0360
0101	0.0299
0110	0.0264
0111	0.0208
1000	0.0198
1001	0.0172
1010	0.0147
1011	0.0137
1100	0.0134
1101	0.0117
1110	0.0110
1111	0.0104 (slow)

LnAT[3:0]	Anti-clipping (AC) (dB relative to FS)
0000	-12
0001	-10
0010	-8
0011	-6
0100	-4
0101	-2
0110	0
0111	2
1000	3
1001	4
1010	5
1011	6
1100	7
1101	8
1110	9
1111	10

LnRT[3:0]	Anti-clipping (AC) (dB relative to FS)
0000	-∞
0001	-29 dB
0010	-20 dB
0011	-16 dB
0100	-14 dB
0101	-12 dB
0110	-10 dB
0111	-8 dB
1000	-7 dB
1001	-6 dB
1010	-5 dB
1011	-4 dB
1100	-3 dB
1101	-2 dB
1110	-1 dB
1111	0 dB

LnAT[3:0]	Dynamic range compression (DRC) (dB relative to volume)
0000	-31
0001	-29
0010	-27
0011	-25
0100	-23
0101	-21
0110	-19
0111	-17
1000	-16
1001	-15
1010	-14
1011	-13
1100	-12
1101	-10
1110	-7
1111	-4

LnRT[3:0]	Dynamic range compression (DRC) (db relative to volume + LnAT)
0000	-∞
0001	-38 dB
0010	-36 dB
0011	-33 dB
0100	-31 dB
0101	-30 dB
0110	-28 dB
0111	-26 dB
1000	-24 dB
1001	-22 dB
1010	-20 dB
1011	-18 dB
1100	-15 dB
1101	-12 dB
1110	-9 dB
1111	-6 dB

5.2.49 Channel 1 and 2 output timing (0x33)

D7	D6	D5	D4	D3	D2	D1	D0
	C2OT2	C2OT1	C2OT0		C1OT2	C1OT1	C1OT0
	1	0	0		0	0	0

5.2.50 Channel 3 and 4 output timing (0x34)

D7	D6	D5	D4	D3	D2	D1	D0
	C4OT2	C4OT1	C4OT0		C3OT2	C3OT1	C3OT0
	1	1	0		0	1	0

5.2.51 Channel 5 and 6 output timing (0x35)

D7	D6	D5	D4	D3	D2	D1	D0
	C6OT2	C6OT1	C6OT0		C5OT2	C5OT1	C5OT0
	1	0	1		0	0	1

5.2.52 Channel 7 and 8 output timing (0x36)

D7	D6	D5	D4	D3	D2	D1	D0
	C8OT2	C8OT1	C8OT0		C7OT2	C7OT1	C7OT0
	1	1	1		0	1	1

The centering of the individual channel PWM output periods can be adjusted by the output timing registers. The PWM slot settings can be chosen to ensure that pulse transitions do not occur at the same time on different channels using the same power device. There are 8 possible settings, the appropriate setting varies based on the application and connections to the FFX power devices.

CnOT[2:0]	PWM slot
000	1
001	2
010	3
011	4
100	5
101	6
110	7
111	8

5.2.53 Coefficient address register 1 (0x3B)

D7	D6	D5	D4	D3	D2	D1	D0
						CFA9	CFA8
						0	0

5.2.54 Coefficient address register 2 (0x3C)

D7	D6	D5	D4	D3	D2	D1	D0
CFA7	CFA6	CFA5	CFA4	CFA3	CFA2	CFA1	CFA0
0	0	0	0	0	0	0	0

5.2.55 Coefficient b1 data register, bits 23:16 (0x3D)

D7	D6	D5	D4	D3	D2	D1	D0
C1B23	C1B22	C1B21	C1B20	C1B19	C1B18	C1B17	C1B16
0	0	0	0	0	0	0	0

5.2.56 Coefficient b1 data register, bits 15:8 (0x3E)

D7	D6	D5	D4	D3	D2	D1	D0
C1B15	C1B14	C1B13	C1B12	C1B11	C1B10	C1B9	C1B8
0	0	0	0	0	0	0	0

5.2.57 Coefficient b1 data register, bits 7:0 (0x3F)

D7	D6	D5	D4	D3	D2	D1	D0
C1B7	C1B6	C1B5	C1B4	C1B3	C1B2	C1B1	C1B0
0	0	0	0	0	0	0	0

5.2.58 Coefficient b2 data register, bits 23:16 (0x40)

D7	D6	D5	D4	D3	D2	D1	D0
C2B23	C2B22	C2B21	C2B20	C2B19	C2B18	C2B17	C2B16
0	0	0	0	0	0	0	0

5.2.59 Coefficient b2 data register, bits 15:8 (0x41)

D7	D6	D5	D4	D3	D2	D1	D0
C2B15	C2B14	C2B13	C2B12	C2B11	C2B10	C2B9	C2B8
0	0	0	0	0	0	0	0

5.2.60 Coefficient b2 data register, bits 7:0 (0x42)

D7	D6	D5	D4	D3	D2	D1	D0
C2B7	C2B6	C2B5	C2B4	C2B3	C2B2	C2B1	C2B0
0	0	0	0	0	0	0	0

5.2.61 Coefficient a1 data register, bits 23:16 (0x43)

D7	D6	D5	D4	D3	D2	D1	D0
C1B23	C1B22	C1B21	C1B20	C1B19	C1B18	C1B17	C1B16
0	0	0	0	0	0	0	0

5.2.62 Coefficient a1 data register, bits 15:8 (0x44)

D7	D6	D5	D4	D3	D2	D1	D0
C3B15	C3B14	C3B13	C3B12	C3B11	C3B10	C3B9	C3B8
0	0	0	0	0	0	0	0

5.2.63 Coefficient a1 data register, bits 7:0 (0x45)

D7	D6	D5	D4	D3	D2	D1	D0
C3B7	C3B6	C3B5	C3B4	C3B3	C3B2	C3B1	C3B0
0	0	0	0	0	0	0	0

5.2.64 Coefficient a2 data register, bits 23:16 (0x46)

D7	D6	D5	D4	D3	D2	D1	D0
C4B23	C4B22	C4B21	C4B20	C4B19	C4B18	C4B17	C4B16
0	0	0	0	0	0	0	0

5.2.65 Coefficient a2 data register, bits 15:8 (0x47)

D7	D6	D5	D4	D3	D2	D1	D0
C4B15	C4B14	C4B13	C4B12	C4B11	C4B10	C4B9	C4B8
0	0	0	0	0	0	0	0

5.2.66 Coefficient a2 data register, bits 7:0 (0x48)

D7	D6	D5	D4	D3	D2	D1	D0
C4B7	C4B6	C4B5	C4B4	C4B3	C4B2	C4B1	C4B0
0	0	0	0	0	0	0	0

5.2.67 Coefficient b0 data register, bits 23:16 (0x49)

D7	D6	D5	D4	D3	D2	D1	D0
C5B23	C5B22	C5B21	C5B20	C5B19	C5B18	C5B17	C5B16
0	0	0	0	0	0	0	0

5.2.68 Coefficient b0 data register, bits 15:8 (0x4A)

D7	D6	D5	D4	D3	D2	D1	D0
C5B15	C5B14	C5B13	C5B12	C5B11	C5B10	C5B9	C5B8
0	0	0	0	0	0	0	0

5.2.69 Coefficient b0 data register, bits 7:0 (0x4B)

D7	D6	D5	D4	D3	D2	D1	D0
C5B7	C5B6	C5B5	C5B4	C5B3	C5B2	C5B1	C5B0
0	0	0	0	0	0	0	0

5.2.70 Coefficient write control register (0x4C)

D7	D6	D5	D4	D3	D2	D1	D0
						WA	W1
						0	0

Coefficients for EQ and Bass Management are handled internally in the STA321MPL1 via the RAM. Access to this RAM is available to the user via an I²C register interface.

A collection of I²C registers are dedicated to this function. One register contains a coefficient base address, five sets of three registers store the values of the 24-bit coefficients to be written or that were read, and one register contains bits used to control the write of the coefficient(s) to the RAM. [Section 5.3](#), [Section 5.4](#), [Section 5.5](#), and [Section 5.6](#) give the instructions for reading and writing coefficients.

5.3 Reading a coefficient from RAM

1. Write the top 2 bits of address to I²C register 0x3B
2. Write the bottom 8 bits of address to I²C register 0x3C
3. Read the top 8 bits of coefficient in I²C address 0x3D
4. Read the middle 8 bits of coefficient in I²C address 0x3E
5. Read the bottom 8 bits of coefficient in I²C address 0x3F

5.4 Reading a set of coefficients from RAM

1. Write the top 2 bits of address to I²C register 0x3B
2. Write the bottom 8 bits of address to I²C register 0x3C
3. Read the top 8 bits of coefficient in I²C address 0x3D
4. Read the middle 8 bits of coefficient in I²C address 0x3E
5. Read the bottom 8 bits of coefficient in I²C address 0x3F
6. Read the top 8 bits of coefficient b2 in I²C address 0x40
7. Read the middle 8 bits of coefficient b2 in I²C address 0x41
8. Read the bottom 8 bits of coefficient b2 in I²C address 0x42
9. Read the top 8 bits of coefficient a1 in I²C address 0x43
10. Read the middle 8 bits of coefficient a1 in I²C address 0x44
11. Read the bottom 8 bits of coefficient a1 in I²C address 0x45
12. Read the top 8 bits of coefficient a2 in I²C address 0x46
13. Read the middle 8 bits of coefficient a2 in I²C address 0x47
14. Read the bottom 8 bits of coefficient a2 in I²C address 0x48
15. Read the top 8 bits of coefficient b0 in I²C address 0x49
16. Read the middle 8 bits of coefficient b0 in I²C address 0x4A
17. Read the bottom 8 bits of coefficient b0 in I²C address 0x4B

5.5 Writing a single coefficient to RAM

1. Write the top 2 bits of address to I²C register 0x3B
2. Write the bottom 8 bits of address to I²C register 0x3C
3. Write the top 8 bits of coefficient in I²C address 0x3D
4. Write the middle 8 bits of coefficient in I²C address 0x3E
5. Write the bottom 8 bits of coefficient in I²C address 0x3F
6. Write 1 to the W1 bit in I²C address 0x4C

5.6 Writing a set of coefficients to RAM

1. Write the top 2 bits of starting address to I²C register 0x3B
2. Write the bottom 8 bits of starting address to I²C register 0x3C
3. Write the top 8 bits of coefficient b1 in I²C address 0x3D
4. Write the middle 8 bits of coefficient b1 in I²C address 0x3E
5. Write the bottom 8 bits of coefficient b1 in I²C address 0x3F
6. Write the top 8 bits of coefficient b2 in I²C address 0x40
7. Write the middle 8-bits of coefficient b2 in I²C address 0x41
8. Write the bottom 8 bits of coefficient b2 in I²C address 0x42
9. Write the top 8 bits of coefficient a1 in I²C address 0x43
10. Write the middle 8 bits of coefficient a1 in I²C address 0x44
11. Write the bottom 8 bits of coefficient a1 in I²C address 0x45
12. Write the top 8 bits of coefficient a2 in I²C address 0x46
13. Write the middle 8 bits of coefficient a2 in I²C address 0x47
14. Write the bottom 8 bits of coefficient a2 in I²C address 0x48
15. Write the top 8-bits of coefficient b0 in I²C address 0x49
16. Write the middle 8 bits of coefficient b0 in I²C address 0x4A
17. Write the bottom 8 bits of coefficient b0 in I²C address 0x4B
18. Write 1 to the WA bit in I²C address 0x4C

The mechanism for writing a set of coefficients to the RAM provides a method of updating the five coefficients corresponding to a given biquad (filter) simultaneously to avoid possible unpleasant acoustic side-effects.

When using this technique, the 10-bit address should specify the address of the biquad b1 coefficient (for example, decimals 0, 5, 10, 15, ..., 100, ... 395), and the STA321MPL1 generates the RAM addresses as offsets from this base value to write the complete set of coefficient data.

6 Configuration registers (0x77; 0x78; 0x79)

CBQ1 (reg 0x77)

D7	D6	D5	D4	D3	D2	D1	D0
EBQ3_1	EBQ3_0	EBQ2_1	EBQ2_0	EBQ1_1	EBQ1_0	EBQ0_0	EBQ0_0
0	0	0	0	0	0	0	0

CBQ2 (reg 0x78)

D7	D6	D5	D4	D3	D2	D1	D0
EBQ7_1	EBQ7_0	EBQ6_1	EBQ6_0	EBQ5_1	EBQ5_0	EBQ4_1	EBQ4_0
0	0	0	0	0	0	0	0

CBQ3 (reg 0x79)

D7	D6	D5	D4	D3	D2	D1	D0
			nshen	EBQ9_1	EBQ9_0	EBQ8_1	EBQ8_0
0	0	0	1	0	0	0	0

The STA321MPL1 EQ biquads use the following equation:

$$Y[n] = 2 * (b_0 / 2) * X[n] + 2 * (b_1 / 2) * X[n-1] + b_2 * X[n-2] - 2 * (a_1 / 2) * Y[n-1] - a_2 * Y[n-2]$$

$$= b_0 * X[n] + b_1 * X[n-1] + b_2 * X[n-2] - a_1 * Y[n-1] - a_2 * Y[n-2]$$

Where Y[n] represents the output and X[n] represents the input. Multipliers are 24-bit signed fractional multipliers, with coefficient values in the range of 0x800000 (-1) to 0x7FFFFFFF (0.9999995231628). The default coefficient range (+/-1) can be reconfigured to ±2 or ±4 with the 0x77, 0x78 and 0x79 I²C registers. The coefficients range setting is common for all the channels.

- (EBQx_1;EBQx_0)="00": Biquad x use +/-1 range
- (EBQx_1;EBQx_0)="01": Biquad x use +/-2 range
- (EBQx_1;EBQx_0)="10": Biquad x use +/-4 range
- (EBQx_1;EBQx_0)="11": reserved

Coefficients stored in the user-defined coefficient RAM are referenced in the following manner:

$$CxHy0 = b_1 / 2$$

$$CxHy1 = b_2$$

$$CxHy2 = -a_1 / 2$$

$$CxHy3 = -a_2$$

$$CxHy4 = b_0 / 2$$

Where x represents the channel and y the biquad number. For example, C0H41 is the b_2 coefficient in the fourth biquad for channel 2.

By default, all user-defined filters are pass-through where all coefficients are set to 0, except the $b_0/2$ coefficient which is set to 0x400000 (representing 0.5). Mix coefficients use only ± 1 range.

A special feature inside the digital processing block is available (active when the nshen bit is set to '1'). In the case where poles are positioned at very low frequencies, biquads filters can generate some audible quantization noise or unwanted DC level. In order to avoid this kind of effect a quantization noise-shaping capability can be used. The filter structure including this special feature, relative to each biquad is shown in [Figure 9](#).

The new feature can be enabled independently for each biquad using the I²C registers. The D7 bit, when set, is responsible for activating this function on the crossover filter while the other bits address any specific biquads according to the previous table. Channels 1 and 2 share the same settings. Bit D7 is effective also for channel 3 if the related OCFG is used.

Figure 9. Biquad filter structure with quantization error noise shaping

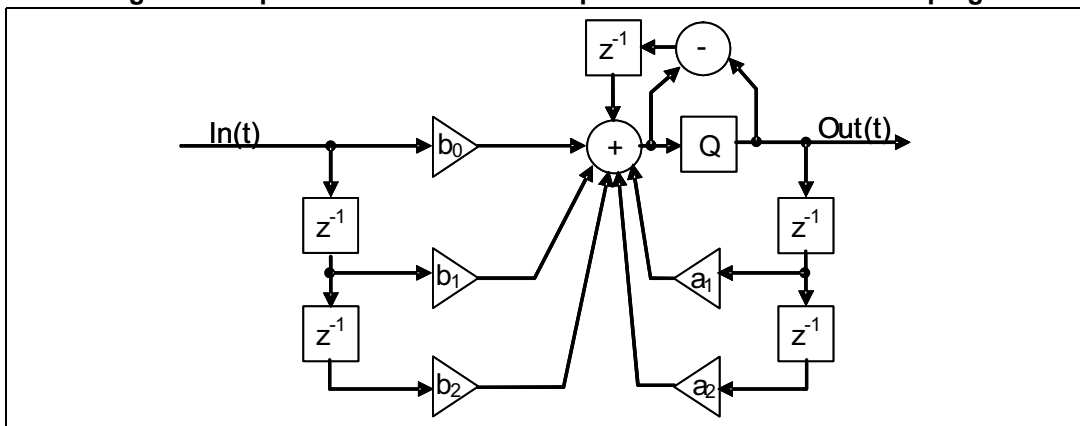
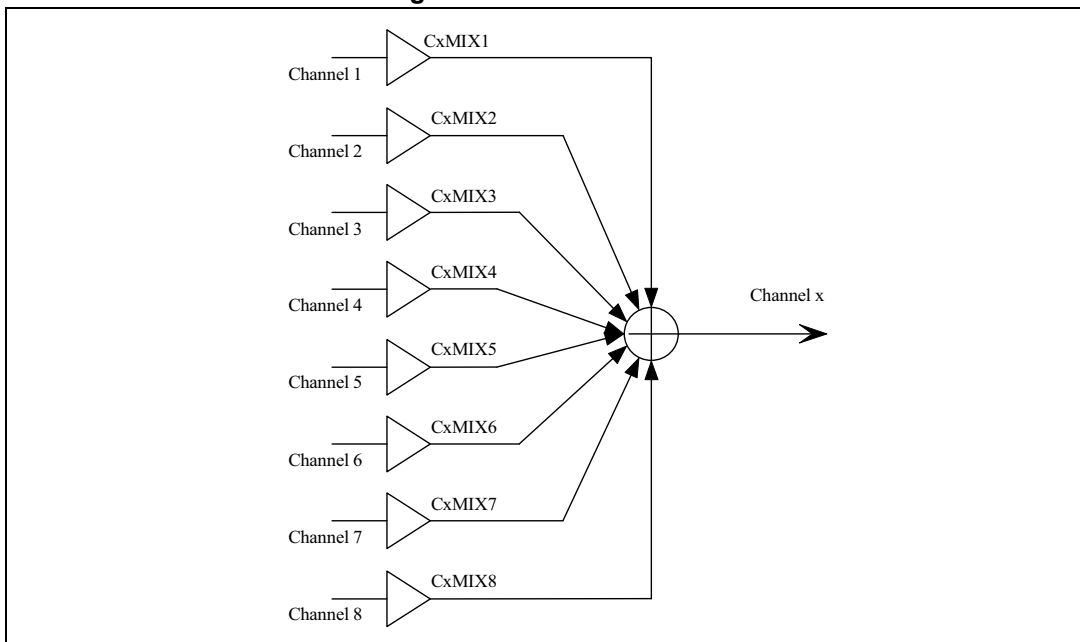

Figure 10. Channel mixer



6.1 Post-scale

The STA321MPL1 provides one additional multiplication after the last interpolation stage and before the distortion compensation on each channel. This is a 24-bit signed fractional multiply.

The scale factor for this multiplication is loaded into the RAM using the same I²C registers as the biquad coefficients and the bass-management.

This post-scale factor can be used in conjunction with an ADC-equipped microcontroller to perform power-supply error corrections. All channels can use channel 1 by setting the post-scale link bit.

Table 11. RAM block for biquads, mixing, and bass management

Index (decimal)	Index (hex)	Parameter	Coefficient	Default
0	0x00	Channel 1 - Biquad 1	C1H10 (b1/2)	0x000000
1	0x01		C1H11 (b2)	0x000000
2	0x02		C1H12 (a1/2)	0x000000
3	0x03		C1H13 (a2)	0x000000
4	0x04		C1H14 (b0/2)	0x400000
5	0x05	Channel 1 - Biquad 2	C1H20	0x000000
...
49	0x31	Channel 1 - Biquad 10	C1HA4	0x400000
50	0x32	Channel 2 - Biquad 1	C2H10	0x000000
51	0x33		C2H11	0x000000
...
99	0x63	Channel 2 - Biquad 10	C2HA4	0x4000000
100	0x64	Channel 3 - Biquad 1	C3H10	0x000000
...
399	0x18F	Channel 8 - Biquad 10	C8HA4	0x400000
400	0x190	Channel 1 - Pre-scale	C1PreS	0x7FFFFFF
401	0x191	Channel 2 - Pre-scale	C2PreS	0x7FFFFFF
402	0x192	Channel 3 - Pre-scale	C3PreS	0x7FFFFFF
...
407	0x197	Channel 8 - Pre-scale	C8PreS	0x7FFFFFF
408	0x198	Channel 1 - Post-scale	C1PstS	0x7FFFFFF
409	0x199	Channel 2 - Post-scale	C2PstS	0x7FFFFFF
...
415	0x19F	Channel 8 - Post-scale	C8PstS	0x7FFFFFF
416	0x1A0	Channel 1 - Mix# 1 1	C1MX11	0x7FFFFFF
417	0x1A1	Channel 1 - Mix#1 2	C1MX12	0x000000

Table 11. RAM block for biquads, mixing, and bass management (continued)

Index (decimal)	Index (hex)	Parameter	Coefficient	Default
...
423	0x1A7	Channel 1 - Mix#1 8	C1MX18	0x000000
424	0x1A8	Channel 2 - Mix#1 1	C2MX11	0x000000
425	0x1A9	Channel 2 - Mix#1 2	C2MX12	0x7FFFFFFF
...
479	0x1DF	Channel 8 - Mix#1 8	C8MX18	0x7FFFFFFF
480	0x1E0	Channel 1 - Mix#2 1	C1MX21	0x7FFFFFFF
481	0x1E1	Channel 1 - Mix#2 2	C1MX22	0x000000
...
487	0x1E7	Channel 1 - Mix#2 8	C1MX28	0x000000
488	0x1E8	Channel 2 - Mix#2 1	C2MX21	0x000000
489	0x1E9	Channel 2 - Mix#2 2	C2MX22	0x7FFFFFFF
...
543	0x21F	Channel 8 - Mix#2 8	C8MX28	0x7FFFFFFF

6.2 Variable max power correction

6.2.1 MPCC1-2 (0x4D, 0x4E)

The MPCC bits determine the 16 MSBs of the MPC compensation coefficient. This coefficient is used in place of the default coefficient when MPCV = 1.

D7	D6	D5	D4	D3	D2	D1	D0
MPCC15	MPCC14	MPCC13	MPCC12	MPCC11	MPCC10	MPCC9	MPCC8
0	0	1	0	1	1	0	1

D7	D6	D5	D4	D3	D2	D1	D0
MPCC7	MPCC6	MPCC5	MPCC4	MPCC3	MPCC2	MPCC1	MPCC0
1	1	0	0	0	0	0	0

6.3 Variable distortion compensation

6.3.1 DCC1-2 (0x4F, 0x50)

The DCC bits determine the 16 MSBs of the distortion compensation coefficient. This coefficient is used in place of the default coefficient when DCCV = 1.

D7	D6	D5	D4	D3	D2	D1	D0
DCC15	DCC14	DCC13	DCC12	DCC11	DCC10	DCC9	DCC8
1	1	1	1	0	0	1	1

D7	D6	D5	D4	D3	D2	D1	D0
DCC7	DCC6	DCC5	DCC4	DCC3	DCC2	DCC1	DCC0
0	0	1	1	0	0	1	1

6.4 PSCorrect registers

An ADC is used to input ripple data to SDI78. The left channel (7) is used internally. No audio data can therefore be used on these channels, although all channel mapping and mixing from other inputs to channels 7 and 8 internally are still valid.

6.4.1 PSC1-2: ripple correction value (RCV) (0x51, 0x52)

This value is equivalent to the negative maximum ripple peak as a percentage of Vcc (MPR), scaled by the inverse of the maximum ripple p-p as a percentage of the full-scale analog input to the ADC. It is represented as a 1.11 signed fractional number.

D7	D6	D5	D4	D3	D2	D1	D0
RCV11	RCV10	RCV9	RCV8	RCV7	RCV6	RCV5	RCV4
0	0	0	0	0	0	0	0

D7	D6	D5	D4	D3	D2	D1	D0
RCV3	RCV2	RCV1	RCV0	CNV11	CNV10	CNV9	CNV8
0	0	0	0	1	1	1	1

6.4.2 PSC3: correction normalization value (CNV) (0x53)

This value is equivalent to $1/(1+MPR)$ expressed as a 0.12 unsigned fractional number.

D7	D6	D5	D4	D3	D2	D1	D0
CNV7	CNV6	CNV5	CNV4	CNV3	CNV2	CNV1	CNV0
1	1	1	1	1	1	1	1

6.5 PDM and recombination IP

6.5.1 Mike recombination RAM BIST (0x5C)

D7	D6	D5	D4	D3	D2	D1	D0
MHFail	MHBad	MHEnd	MHAct	MNFail	MNBad	MNEnd	MNAct
0	0	0	0	0	0	0	0

Bit	RW	RST	Name	Description
7	RW	0	MHFail	'1': MHBist computation bit fail
6	RW	0	MHBad	'1': MHBist computation bad
5	RW	0	MHEnd	'1': MHBist computation finished
4	RW	0	MHAct	'1': MHBist computation start
3	RW	0	MNFail	'1': MNBist computation bit fail
2	RW	0	MNBad	'1': MNBist computation bad
1	RW	0	MNEnd	'1': MNBist computation finished
0	RW	0	MNAct	'1': MNBist computation start

6.5.2 Recombination control register 1 (0x5D)

D7	D6	D5	D4	D3	D2	D1	D0
Boost6db					mike_en	mike_byp	m_mode
0	0	0	0	0	0	0	0

Bit	RW	RST	Name	Description
7	RW	0	Boost6dB ⁽¹⁾	'1': Output (after recombination) multiplied x2 '0': Output (after recombination) as it is
6	RW	0		
5	RW	0		
4	RW	0		
3	RW	0		
2	RW	0	mike_en	'1': Microphone recombination IP is active '0': Microphone recombination IP is not active (acts like an HW Bypass)
1	RW	0	mike_byp	'1': Microphone recombination is bypassed '0': Microphone recombination is used
0	RW	0	m_mode	'1': Auto-configuration of the CLKOUT generator to Fout = sys_clk/32 '0': CLKOUT is configured only through COS bits

1. Microphone recombination only

6.5.3 PDM control register (0x5E)

D7	D6	D5	D4	D3	D2	D1	D0
AdvM6	AdvM5	AdvM4	AdvM3	AdvM2	AdvM1	PDMSM[1:0]	
0	0	0	0	0	0	0	0

Bit	RW	RST	Name	Description
7	RW		AdvM6	PDM channel x sampling edge configuration: '1': rising edge (of internal _CLK) '0': falling edge (of internal _CLK) (Active in Advance mode only, PDMSM = '11')
6	RW		AdvM5	
5	RW		AdvM4	
4	RW		AdvM3	
3	RW		AdvM2	
2	RW		AdvM1	
1	RW		PDMSM	00: Normal mode
0	RW			01: reserved
				10: Dual-membrane
				11: Advanced

6.5.4 Recombination control register 2, 3, and 4 (0x5F; 0x60; 0x61)

D7	D6	D5	D4	D3	D2	D1	D0
	bypRM1	CH1GG[5:0]					
0	0	1	0	0	0	0	0

D7	D6	D5	D4	D3	D2	D1	D0
	bypRM2	CH2GG[5:0]					
0	0	1	0	0	0	0	0

D7	D6	D5	D4	D3	D2	D1	D0
	bypRM3	CH3GG[5:0]					
0	0	1	0	0	0	0	0

Bit	RW	RST	Name	Description
7	RW		reserved	
6	RW		bypRMx	'1': Recombination of Mike_x is bypassed '0': Recombination of Mike_x is active
5	RW		CHxGG[5:0]	see Table 12
4	RW			
3	RW			
2	RW			
1	RW			
0	RW			

Table 12. Gain adjustment (sensitivity)

Index	dB	Index	dB	Index	dB
0x00	-4	0x16	-1.25	0x2C	1.5
0x01	-3.875	0x17	-1.125	0x2D	1.625
0x02	-3.75	0x18	-1	0x2E	1.75
0x03	-3.625	0x19	-0.875	0x2F	1.875
0x04	-3.5	0x1A	-0.75	0x30	2
0x05	-3.375	0x1B	-0.625	0x31	2.125
0x06	-3.25	0x1C	-0.5	0x32	2.25
0x07	-3.125	0x1D	-0.375	0x33	2.375
0x08	-3	0x1E	-0.25	0x34	2.5
0x09	-2.875	0x1F	-0.125	0x35	2.625
0x0A	-2.75	0x20	0	0x36	2.75
0x0B	-2.625	0x21	0.125	0x37	2.875
0x0C	-2.5	0x22	0.25	0x38	3
0x0D	-2.375	0x23	0.375	0x39	3.125
0x0E	-2.25	0x24	0.5	0x3A	3.25
0x0F	-2.125	0x25	0.625	0x3B	3.375
0x10	-2	0x26	0.75	0x3C	3.5
0x11	-1.875	0x27	0.875	0x3D	3.625
0x12	-1.75	0x28	1	0x3E	3.75
0x13	-1.625	0x29	1.125	0x3F	3.875
0x14	-1.5	0x2A	1.25		
0x15	-1.375	0x2B	1.375		

6.5.5 Recombination control register 5, 6, and 7 (0x62; 0x63; 0x64)

D7	D6	D5	D4	D3	D2	D1	D0
	LP1en	CH1NCA[5:0]					
0	1	1	0	0	0	0	0

D7	D6	D5	D4	D3	D2	D1	D0
	LP2en	CH2NCA[5:0]					
0	1	1	0	0	0	0	0

D7	D6	D5	D4	D3	D2	D1	D0
	LP3en	CH3NCA[5:0]					
0	1	1	0	0	0	0	0

Bit	RW	RST	Name	Description
7	RW			
6	RW		LPxen	'1': Low-pass filter of mike x is enabled '0': Low-pass filter of mike x is not enabled
5	RW		CHxNCA[5:0]	see Table 13
4	RW			
3	RW			
2	RW			
1	RW			
0	RW			

Table 13. Normal channel attenuation

Index	dB	Index	dB	Index	dB
0x00	0	0x16	18.75	0x2C	21.5
0x01	10.5	0x17	18.875	0x2D	21.625
0x02	11	0x18	19	0x2E	21.75
0x03	11.5	0x19	19.125	0x2F	21.875
0x04	12	0x1A	19.25	0x30	22
0x05	12.5	0x1B	19.375	0x31	22.5
0x06	13	0x1C	19.5	0x32	23
0x07	13.5	0x1D	19.625	0x33	23.5
0x08	14	0x1E	19.75	0x34	24
0x09	14.5	0x1F	19.875	0x35	24.5
0x0A	15	0x20	20	0x36	25
0x0B	15.5	0x21	20.125	0x37	25.5
0x0C	16	0x22	20.25	0x38	26
0x0D	16.5	0x23	20.375	0x39	26.5
0x0E	17	0x24	20.5	0x3A	27
0x0F	17.5	0x25	20.625	0x3B	27.5
0x10	18	0x26	20.75	0x3C	28
0x11	18.125	0x27	20.875	0x3D	28.5
0x12	18.25	0x28	21	0x3E	29
0x13	18.375	0x29	21.125	0x3F	29.5
0x14	18.5	0x2A	21.25		
0x15	18.625	0x2B	21.375		

6.5.6 Recombination control register 8, 9, and 10 (0x65; 0x66; 0x67)

D7	D6	D5	D4	D3	D2	D1	D0
		CH1TH_N[5:0]					
0	0	1	1	0	0	1	1

D7	D6	D5	D4	D3	D2	D1	D0
		CH2TH_N[5:0]					
0	0	1	1	0	0	1	1

D7	D6	D5	D4	D3	D2	D1	D0
		CH3TH_N[5:0]					
0	0	1	1	0	0	1	1

Bit	RW	RST	Name	Description
7	RW			Reserved
6	RW			
5	RW		CHxTH_N[5:0]	see Table 14
4	RW			
3	RW			
2	RW			
1	RW			
0	RW			

Table 14. Threshold configuration

Index	dB	Index	dB	Index	dB	Index	dB	Index	dB	Index	dB
0x00	0	0x0B	-11	0x16	-22	0x21	-33	0x2C	-44	0x37	-55
0x01	-1	0x0C	-12	0x17	-23	0x22	-34	0x2D	-45	0x38	-56
0x02	-2	0x0D	-13	0x18	-24	0x23	-35	0x2E	-46	0x39	-57
0x03	-3	0x0E	-14	0x19	-25	0x24	-36	0x2F	-47	0x3A	-58
0x04	-4	0x0F	-15	0x1A	-26	0x25	-37	0x30	-48	0x3B	-59
0x05	-5	0x10	-16	0x1B	-27	0x26	-38	0x31	-49	0x3C	-60
0x06	-6	0x11	-17	0x1C	-28	0x27	-39	0x32	-50	0x3D	-61
0x07	-7	0x12	-18	0x1D	-29	0x28	-40	0x33	-51	0x3E	-62
0x08	-8	0x13	-19	0x1E	-30	0x29	-41	0x34	-52	0x3F	-63
0x09	-9	0x14	-20	0x1F	-31	0x2A	-42	0x35	-53		
0x0A	-10	0x15	-21	0x20	-32	0x2B	-43	0x36	-54		

6.5.7 Recombination control register 11, 12, and 13 (0x68; 0x69; 0x6A)

D7	D6	D5	D4	D3	D2	D1	D0
CH1TH_H[5:0]							
0	0	0	1	1	0	1	1

D7	D6	D5	D4	D3	D2	D1	D0
CH2TH_H[5:0]							
0	0	0	1	1	0	1	1

D7	D6	D5	D4	D3	D2	D1	D0
CH3TH_H[5:0]							
0	0	0	1	1	0	1	1

Bit	RW	RST	Name	Description
7	RW	0		Reserved
6	RW	0		
5	RW	0	CHxHCT[5:0]	see Table 14
4	RW	1		
3	RW	1		
2	RW	0		
1	RW	1		
0	RW	1		

6.5.8 Zero-mute threshold/hysteresis and RMS zero-mute selectors (0x6F)

Zero-mute (0x6F)

D7	D6	D5	D4	D3	D2	D1	D0
RMSZS2	RMSZS1	RMSZS0	ZMTHS2	ZMTHS1	ZMTHS0	ZMHYS1	ZMHYS0
0	0	0	0	0	0	0	0

Bit	RW	RST	Name	Description
7	RW	0	RMSZS2	Select channel for reading the zero-mute RMS level on registers rmsZMH (0x7A) and rmsZML (0x7B).
6	RW	0	RMSZS1	
5	RW	0	RMSZS0	
4	RW	0	ZMTHS2	Select the zero-mute threshold level. If signal is below this level, output will be in switch off mode.
3	RW	0	ZMTHS1	
2	RW	0	ZMTHS0	
1	RW	0	ZMHYS1	Select the hysteresis window width.
0	RW	0	ZMHYS0	

The STA321MPL1 implements an RMS-based zero-detect function (on serial input interface data) which is able to detect in a very reliable way the presence of an input signal, so that the power bridge outputs can be automatically connected to ground. When active, the function mutes the output PWM when the input level becomes less than the threshold - hysteresis.

Once muted, the PWM “unmutes” when the input level is detected as greater than the threshold + hysteresis.

The measured level is then reported (each input channel is selected by the RMSZS[2:0] value) on registers 0x7A and 0x7B.

Table 15. RMS channel select

RMSZS[2:0]	Channel
000	1
001	2
010	3
011	4
100	5
101	6
110	7
111	8

Table 16. Zero-detect threshold

ZMTHS[2:0]	Equivalent input level (dB)
000	-78
001	-84
010	-90
011	-96
100	-102
101	-108
110	-114
111	-114

Table 17. Zero-detect hysteresis

ZMHYS[1:0]	Equivalent input level hysteresis (dB)
00	3
01	4
10	5
11	6

6.5.9 RMS post-processing selectors and Fs autodetection (0x70)

D7	D6	D5	D4	D3	D2	D1	D0
RMSOS2	RMSOS1	RMSOS0					FXLR0
0	0	0	0	0	0	0	0

RMS out selector

Bit	RW	RST	Name	Description
7	RW	0	RMSOS2	RMS post-processing selectors. For each channel, the current RMS value after the processing step is available on registers rmsPOH (0x7C) and rmsPOL (0x7D).
6	RW	0	RMSOS1	
5	RW	0	RMSOS0	

Table 18. RMS post-processing channel select

RMSOS[2:0]	Channel
000	1
001	2
010	3
011	4
100	5
101	6
110	7
111	8

Fs autodetection

Bit	RW	RST	Name	Description
0	RW	0	FXLR0	If set to 1, the IR and BST32K parameters are auto-selected by the Fs autodetection internal block; otherwise, the I ² C register values are used.

6.5.10 Clock manager configuration

PLL configuration registers (0x71, 0x72, 0x73, 0x74)

PLL multiplication factor (fractional part, H) (0x71)

D7	D6	D5	D4	D3	D2	D1	D0
PLLFI[15:8]							
0	0	0	0	0	0	0	0

PLL multiplication factor (fractional part, L) (0x72)

D7	D6	D5	D4	D3	D2	D1	D0
PLLFI[7:0]							
0	0	0	0	0	0	0	0

PLL multiplication factor (integral part) named as N Division Factor (NDIV) and dithering (0x73)

D7	D6	D5	D4	D3	D2	D1	D0
PLLDD[1:0]		PLLND[5:0]					
0	0	0	0	0	0	0	0

Bit	RW	RST	Name	Description
7	RW	0	PLLDD1	PLL dithering: 00: PLL clock dithering disabled 01: PLL clock dithering enabled (triangular) 10: PLLclock dithering enabled (rectangular) 11: reserved
6	RW	0	PLLDD0	
5	RW	0	PLLND5	N (loop) Division Factor This factor should be: $5 \leq NDIV \leq 55$
4	RW	0	PLLND4	
3	RW	0	PLLND3	
2	RW	1	PLLND2	
1	RW	0	PLLND1	
0	RW	1	PLLND0	

PLL input division factor and others (0x74)

D7	D6	D5	D4	D3	D2	D1	D0
PDPDC	PLLFC	PLSTRB	PLSTBB	PLIDF3	PLIDF2	PLIDF1	PLIDF0
0	0	0	0	0	0	0	0

By default the STA321MPL1 is able to configure the embedded PLL automatically depending on the MCS bits (reg 0x00). For certain applications and to provide flexibility to the user, a manual PLL configuration can be used (setting PLLFC to 1). The output PLL frequency formula is:

$$F_{out} = \frac{F_{in}}{IDF} \times \left(ND + \frac{FI}{2^{16}} \right) \quad \text{when PLLFC} = 1$$

$$F_{out} = \frac{F_{in}}{IDF} \times (ND) \quad \text{when PLLFC} = 0$$

Clock manager configuration register (0x75)

D7	D6	D5	D4	D3	D2	D1	D0
				PLLBYB	PLLDPR	LOWEN	BST32K
				0	0	0	0

Bit	RW	RST	Name	Description
3	RW	0	PLLBYB	PLL bypass enable '0': disabled '1': bypassed
2	RW	0	PLLDPR	PLL direct programming '0': PLL configuration depends on MCS '1': PLL configuration depends on I ² C regs (0x72, 0x73 and 0x74)
1	RW	0	LOWEN	Low clock enable '0': if input clock is too slow, master clock will become the internal oscillator clock (20 MHz), PLL bypassed '1': disabled
0	RW	0	BST32K	Boost oversampling for fs = 32 kHz '0': disabled '1': input oversampling is selected x 3

Clock manager status register (0x76)

D7	D6	D5	D4	D3	D2	D1	D0
				PLLBY5	PLLPDS	OSCOK	LOWCK5
				0	0	0	0

Bit	RW	RST	Name	Description
3	R	0	PLLBY5	PLL bypass status '0': normal '1': bypassed
2	R	0	PLLPDS	PLL power-down status '0': normal '1': standby
1	R	0	OSCOK	Oscillator clock OK '0': not ready '1': ready
0	R	0	LOWCK5	Low clock status '0': normal '1': input clock too slow

6.5.11 RMS level registers (0x7A, 0x7B, 0x7C, 0x7D)

Two sets of registers are available to monitor the RMS level detected by the zero-mute block after signal processing.

The measured level for a selected channel is given in 0x7A and 0x7B (zero-mute level) and 0x7C and 0x7D (PWM out level) according to the following expression:

$$\text{Value(dB)} = 20\text{Log}(\text{rms}[15:0]/(2^{16} \times 0.635))$$

Where rms[15:0] is an unsigned integer formed by:

rms[15:0] = rmsZMH[7:0], rmsZML[7:0] for zero-mute level
 or
 rms[15:0] = rmsPOH[7:0], rmsPOL[7:0] for PWM output level

rmsZMx

D7	D6	D5	D4	D3	D2	D1	D0
RZM15	RZM14	RZM13	RZM12	RZM11	RZM10	RZM9	RZM8
0	0	0	0	0	0	0	0
RZM7	RZM6	RZM5	RZM4	RZM3	RZM2	RZM1	RZM0
0	0	0	0	0	0	0	0

rmsZMH

Bit	RW	RST	Name	Description
7	R		RZM15	RMS zero-detect level register, H
6	R		RZM14	
5	R		RZM13	
4	R		RZM12	
3	R		RZM11	
2	R		RZM10	
1	R		RZM9	
0	R		RZM8	

rmsZML

Bit	RW	RST	Name	Description
7	R		RZM7	RMS zero detect level register, L
6	R		RZM6	
5	R		RZM5	
4	R		RZM4	
3	R		RZM3	
2	R		RZM2	
1	R		RZM1	
0	R		RZM0	

rmsPOx

D7	D6	D5	D4	D3	D2	D1	D0
RPO15	RPO14	RPO13	RPO12	RPO11	RPO10	RPO9	RPO8
0	0	0	0	0	0	0	0
RPO7	RPO6	RPO5	RPO4	RPO3	RPO2	RPO1	RPO0
0	0	0	0	0	0	0	0

rmsPOH

Bit	RW	RST	Name	Description
7	R		RPO15	RMS PWM out (post-processing) register, H
6	R		RPO14	
5	R		RPO13	
4	R		RPO12	
3	R		RPO11	
2	R		RPO10	
1	R		RPO9	
0	R		RPO8	

rmsPOL

Bit	RW	RST	Name	Description
7	R		RPO7	RMS PWM out (post-processing) register, L
6	R		RPO6	
5	R		RPO5	
4	R		RPO4	
3	R		RPO3	
2	R		RPO2	
1	R		RPO1	
0	R		RPO0	

7 Startup/shutdown pop noise removal

7.1 DPT: PWM and tristate delay (0x80)

D7	D6	D5	D4	D3	D2	D1	D0
			DPT4	DPT3	DPT2	DPT1	DPT0
			1	1	1	0	0

Bit	RW	RST	Name	Description
0	RW	0	DPT0	Set a delay between the PWM and the tristate signal to compensate the external amplifier delay.
1	RW	0	DPT1	
2	RW	1	DPT2	
3	RW	1	DPT3	
4	RW	1	DPT4	

7.2 Configuration register (0x81)

D7	D6	D5	D4	D3	D2	D1	D0
RL3	RL2	RL1	RL0	RD	SID1	FBYP	RTP
0	0	0	0	0	1	0	1

Bit	RW	RST	Name	Description
0	RW	1	RTP	Remove tristate initial pulses 1: remove the tristate initial pulses with frequency less than 16 kHz 0: the tristate initial pulses are not removed

Bit	RW	RST	Name	Description
1	RW	0	FBYP	Fault user-defined bypass mode 1: the fault internal management is disabled 0: the fault internal management is enabled

Bit	RW	RST	Name	Description
2	RW	1	SID1	Serial interface (I ² S out) 1: SDO_56 is connected to the fault signal and SDO_78 outputs the tristate signal 0: I ² S out normal

Bit	RW	RST	Name	Description
3	RW	0	RD	Startup/shutdown pop noise disable 1: the startup/shutdown tristate sequence used to remove the pop noise is disabled 0: the startup/shutdown tristate signal sequence used to remove the pop noise is enabled. This feature is available only when PWMS output speed is set to 384 kHz.

Bit	RW	RST	Name	Description
4	RW	0	RL0	Set a tristate duration (same value for startup/shutdown pop noise removal)
5	RW	0	RL1	
6	RW	0	RL2	
7	RW	0	RL3	

RL[3:0]	Tristate duration
0000	default duration equal to 116 ms
0001	default value x2
0010	default value x3
0011	default value x4
0100	default value x5
0101	default value x6
0110	default value x7

7.3 User-defined delay time (0x82) and (0x83)

D7	D6	D5	D4	D3	D2	D1	D0
UDDT15	UDDT14	UDDT13	UDDT12	UDDT11	UDDT10	UDDT9	UDDT8
0	0	0	0	0	0	0	0

D7	D6	D5	D4	D3	D2	D1	D0
UDDT7	UDDT6	UDDT5	UDDT4	UDDT3	UDDT2	UDDT1	UDDT0
1	1	1	1	1	1	1	1

8 Package information

In order to meet environmental requirements, ST offers these devices in different grades of ECOPACK[®] packages, depending on their level of environmental compliance. ECOPACK[®] specifications, grade definitions and product status are available at: www.st.com. ECOPACK[®] is an ST trademark.

8.1 TQFP64 (10 mm x 10 mm) package information

Figure 11. TQFP64 (10 mm x 10 mm) package outline

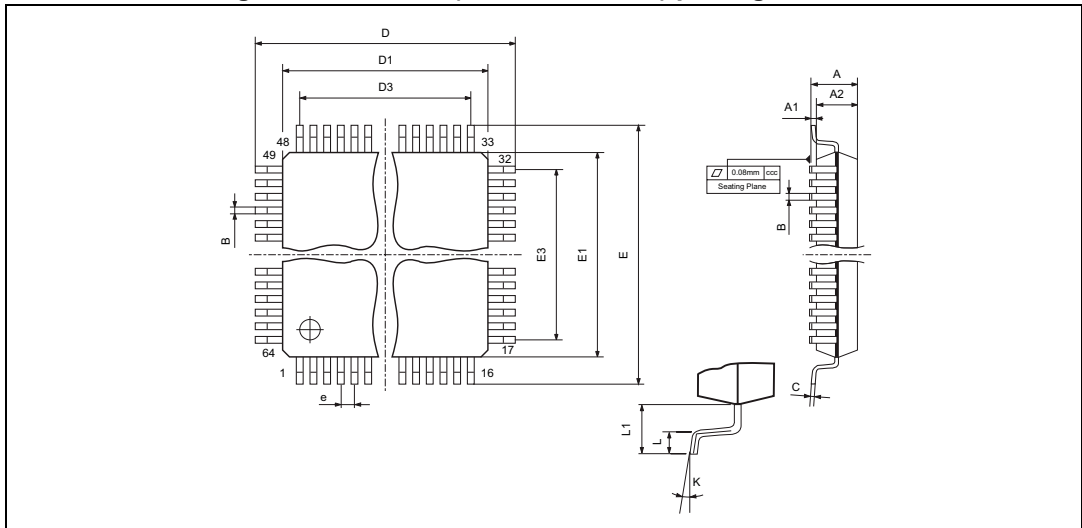

Table 19. TQFP64 (10 mm x 10 mm) mechanical data

Ref.	Dimensions					
	Millimeters			Inches		
	Min.	Typ.	Max.	Min.	Typ.	Max.
A			1.60			0.063
A1	0.05		0.15	0.002		0.006
A2	1.35	1.40	1.45	0.053	0.055	0.057
B	0.17	0.22	0.27	0.0066	0.0086	0.0106
C	0.09			0.0035		
D	11.80	12.00	12.20	0.464	0.472	0.480
D1	9.80	10.00	10.20	0.386	0.394	0.401
D3		7.50			0.295	
e		0.50			0.0197	
E	11.80	12.00	12.20	0.464	0.472	0.480
E1	9.80	10.00	10.20	0.386	0.394	0.401
E3		7.50			0.295	
L	0.45	0.60	0.75	0.0177	0.0236	0.0295
L1		1.00			0.0393	
K	0 ° min, 3.5 ° typ, 7 ° max					
ccc			0.080			0.0031

9 Revision history

Table 20. Document revision history

Date	Revision	Changes
28-Jun-2016	1	Initial release

IMPORTANT NOTICE – PLEASE READ CAREFULLY

STMicroelectronics NV and its subsidiaries (“ST”) reserve the right to make changes, corrections, enhancements, modifications, and improvements to ST products and/or to this document at any time without notice. Purchasers should obtain the latest relevant information on ST products before placing orders. ST products are sold pursuant to ST’s terms and conditions of sale in place at the time of order acknowledgement.

Purchasers are solely responsible for the choice, selection, and use of ST products and ST assumes no liability for application assistance or the design of Purchasers’ products.

No license, express or implied, to any intellectual property right is granted by ST herein.

Resale of ST products with provisions different from the information set forth herein shall void any warranty granted by ST for such product.

ST and the ST logo are trademarks of ST. All other product or service names are the property of their respective owners.

Information in this document supersedes and replaces information previously supplied in any prior versions of this document.

© 2016 STMicroelectronics – All rights reserved

Данный компонент на территории Российской Федерации

Вы можете приобрести в компании MosChip.

Для оперативного оформления запроса Вам необходимо перейти по данной ссылке:

<http://moschip.ru/get-element>

Вы можете разместить у нас заказ для любого Вашего проекта, будь то серийное производство или разработка единичного прибора.

В нашем ассортименте представлены ведущие мировые производители активных и пассивных электронных компонентов.

Нашей специализацией является поставка электронной компонентной базы двойного назначения, продукции таких производителей как XILINX, Intel (ex.ALTERA), Vicor, Microchip, Texas Instruments, Analog Devices, Mini-Circuits, Amphenol, Glenair.

Сотрудничество с глобальными дистрибьюторами электронных компонентов, предоставляет возможность заказывать и получать с международных складов практически любой перечень компонентов в оптимальные для Вас сроки.

На всех этапах разработки и производства наши партнеры могут получить квалифицированную поддержку опытных инженеров.

Система менеджмента качества компании отвечает требованиям в соответствии с ГОСТ Р ИСО 9001, ГОСТ РВ 0015-002 и ЭС РД 009

Офис по работе с юридическими лицами:

105318, г.Москва, ул.Щербаковская д.3, офис 1107, 1118, ДЦ «Щербаковский»

Телефон: +7 495 668-12-70 (многоканальный)

Факс: +7 495 668-12-70 (доб.304)

E-mail: info@moschip.ru

Skype отдела продаж:

moschip.ru

moschip.ru_4

moschip.ru_6

moschip.ru_9