

OM13584

PTN5150A USB Type-C CC Logic and PTN36043 SuperSpeed
Active Demux Application Board User's Manual
Rev. 2.0 - 8/8/16

Document information

Info	Content
Keywords	PTN5150A, PTN36043, NX5P3090, USB Type-C, CC Logic, Orientation Detection, SuperSpeed, Active Demux, Redriver, Load Switch, Discrete Logic
Abstract	This user manual presents demonstration / application board capability of interfacing an USB3.0 xHCI controller to USB Type-C port. The application board is intended for use as an evaluation and customer demonstration tool, as well as a reference design.

OM13584

PTN5150A USB Type-C CC Logic and PTN36043 SuperSpeed Active Demux Application Board User's Manual

Rev. 2.0 - 8/8/16

Revision history

Rev	Date	Description
2.0	8/8/2016	Update For New Reference Design (Revision A3)
1.0	5/28/2015	Initial release

OM13584

PTN5150A USB Type-C CC Logic and PTN36043 SuperSpeed
Active Demux Application Board User's Manual
Rev. 2.0 - 8/8/16

1. Introduction

PTN36043 is a very small, low power 2 differential channel 2 to 1 active demultiplexer with integrated SuperSpeed USB 3.0 redriver IC that can switch two differential signals to one of two locations. The active demux has optimized performance with minimized crosstalk, as required by the high-speed serial interface for type C connector. PTN36043 allows expansion of existing high speed ports for very low power consumption.

PTN5150A is a small thin low power CC Logic chip supporting the USB Type-C connector application with Configuration Channel (CC) control logic detection and indication functions. The features of PTN5150A enable USB Type-C connector to be used in both host and device ends of the Type-C cable. It can support Type-C to USB legacy cables and adapters defined in USB Type-C Spec. PTN5150A can work autonomously, or can connect to a controller through I2C-bus interface.

This document describes the user's manual of PTN36043 USB Type-C SuperSpeed Active Demux, and also PTN5150A CC logic chip for orientation detection on the USB Type-C cables, including

- Overall PCB connectors, jumpers, and power supplies
- Equipment/Tools that this board will be interfacing with for board testing
- System level connections such as cables and connectors that this board will be plugged into

1.1 Purposes

- For engineers to evaluate the performance of PTN36043, including verifying system level features/performances/functionalities such as
 - Signal integrity measurements such as jitter and eye diagrams
 - Verify power management schemes in U0/U1/U2/U3 states
 - Power consumption measurement during U0/U1/U2/U3 states.
 - Allow access to settings such as receiver equalizer and transmitter output swing level and de-emphasis for the channel facing the application processor side, or for the channel USB Type-C connector side.
- For engineers to evaluate the performance of PTN5150A, including verifying system level features/performances/functionalities such as
 - CC logic (CC1/CC2) orientation detection

OM13584

PTN5150A USB Type-C CC Logic and PTN36043 SuperSpeed Active Demux Application Board User's Manual

Rev. 2.0 - 8/8/16

- Various DFP current mode settings, and other interrupt functions thru I²C interface
- Generic non-I2C (GPIO) mode to interface with PTN36043.
- Verify power management schemes in active and power down states

2. General Description

2.1 *Layout of PTN36043 and PTN5150A*

This application board is designed to evaluate PTN36043 and PTN5150A specifically. Socket footprints are no longer available on the evaluation board, and only IC footprints are provided for direct soldering purpose.

There are two possible configurations to use this application board

1. Host (DFP) Mode – connect to a host PC via a standard A-A cable (cables are not provided), and connect to a device via a USB-Type-C to Type-A receptacle.
2. Device (UFP) Mode – connect to a host PC (such as Macbook or Chromebook) via a standard type-C cable, and connect to a device (such as thumb drive) via on-board Type-A receptacle.

PTN5150A has special EXT_SEL feature that can be used to select which path to enable on PTN36043, based on the type-C cable's orientation. Note that PTN5150A does not have this feature, and thus won't be easy to demonstrate the selection function. If customers would like to evaluation PTN5150, please make a special request to marketing, and we can provide the correct part number for evaluation.

OM13584

PTN5150A USB Type-C CC Logic and PTN36043 SuperSpeed
Active Demux Application Board User's Manual
Rev. 2.0 - 8/8/16

2.3 Demo Board Features

- Configuration jumpers for PT36043 AP & CONN channels.
- PTN5150A Type-C CC Controller
 - LED status indications and probing headers for PTN5150A
 - I2C interface header (compatible with Aardvark I²C/SPI Host Adapter)
- Host (DFP) Mode and Device (UFP) Mode
- Load switch for sourcing 5V to Type-C connector (DFP mode)
- Load switch for sinking 5V from Type-C connector (UFP mode)
- On board 3.3V and 1.8V LDOs for PTN36043 and PTN5150A
- Powered From USB Type-A VBus, or USB Type-C VBus, or External +5V power supply input header.

OM13584

PTN5150A USB Type-C CC Logic and PTN36043 SuperSpeed
Active Demux Application Board User's Manual
Rev. 2.0 - 8/8/16

3.3 Source Load Switch

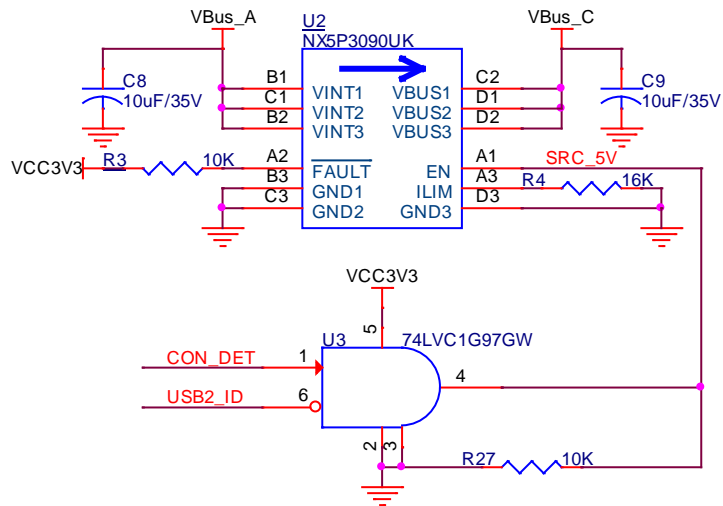

3.4 Sink Load Switch

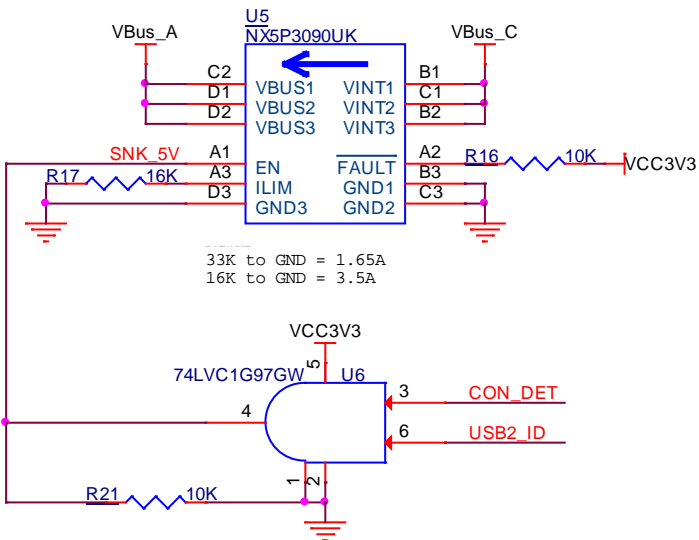

OM13584

PTN5150A USB Type-C CC Logic and PTN36043 SuperSpeed Active Demux Application Board User's Manual
Rev. 2.0 - 8/8/16

3.5 VBus Discharge Circuit

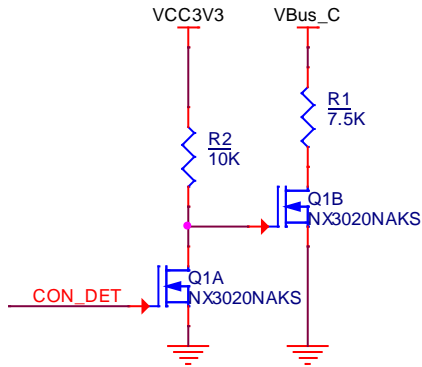

3.6 On-Board LDOs

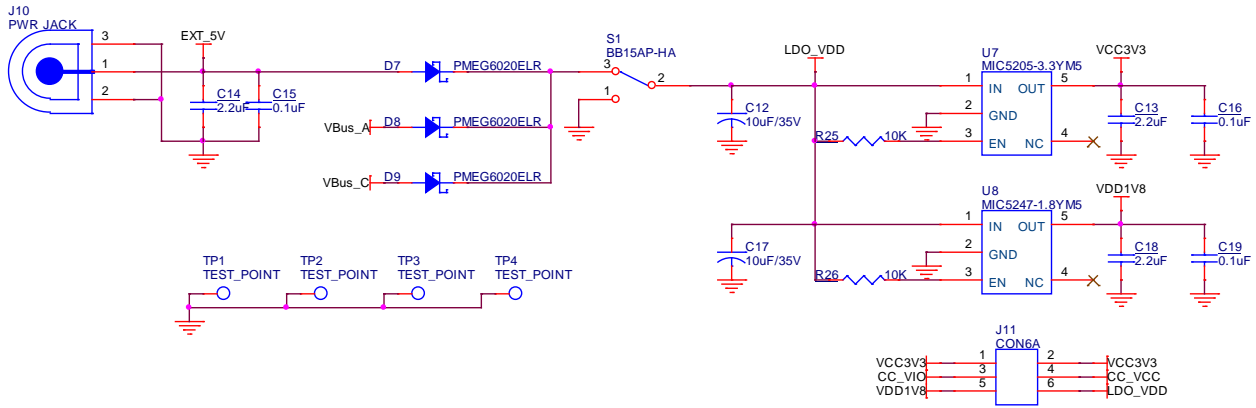

3.7 LEDs and Headers

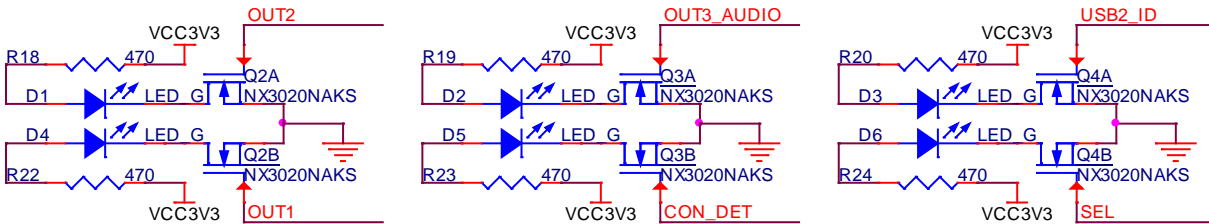

OM13584

PTN5150A USB Type-C CC Logic and PTN36043 SuperSpeed
Active Demux Application Board User's Manual
Rev. 2.0 - 8/8/16

4. Connector Functions

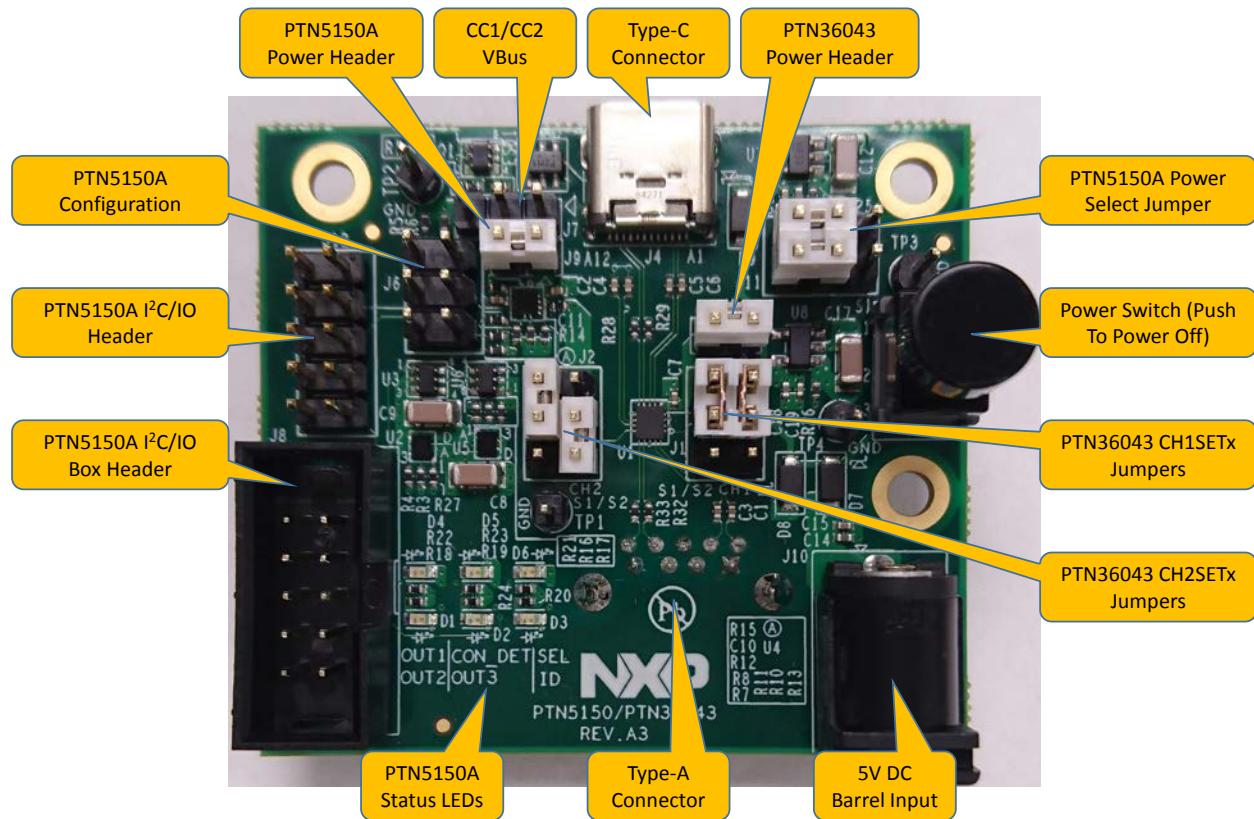

4.1 Board Power

This demo board can be powered from three different power sources:

- USB Type-A (DFP mode, from a Type-A host)
- USB Type-C (UFP mode, from a Type-C host)
- DC Barrel (5V)

Three different power paths are diode-ORed together through D7/D8/D9 to provide power input to 3.3V and 1.8V LDOs. A momentary toggle switch (S1) is used to disconnect power inputs to LDOs while pressing down. By default, the momentary toggle switch is in the ON position.

4.2 Power Measurement

Customers can use J5 for PTN36043 power measurement, and J9 for PTN5150A power measurement. Note that PTN5150A's VDD can be up to 5.5V, and IO voltage

OM13584

PTN5150A USB Type-C CC Logic and PTN36043 SuperSpeed Active Demux Application Board User's Manual Rev. 2.0 - 8/8/16

can be varied by changing J11 setting. For normal operation, jumpers should be installed on J5 and J11.

4.3 PTN36043 Channel Settings

PTN36043 channel settings can be adjusted through J1 (CH1SETx) and J2 (CH2SETx). CH1SETx is used to set channel condition on the USB Type-A side, and CH2SETx is used to set channel condition on the USB Type-C side. The following tables describes detail DE/OS/EQ settings of each header.

CH1_SET1	CH1_SET2	RX_AP± DE	RX_AP± OS	TX_AP± EQ
Low	Low	-3.9 dB	1100 mV	3.0 dB
Low	Open	-3.5 dB	900 mV	3.0 dB
Low	High	0 dB	1100 mV	3.0 dB
Open	Low	0 dB	900 mV	3.0 dB
Open	Open	-3.9 dB	1100 mV	0 dB
Open	High	-3.5 dB	900 mV	0 dB
High	Low	0 dB	1100 mV	0 dB
High	Open	0 dB	900 mV	0 dB
High	High	-5.3 dB	1100 mV	6.0 dB

CH2_SET1	CH2_SET2	TX_CON_1/2± DE	TX_CON_1/2± OS	RX_CON_1/2± EQ
Low	Low	-5.3 dB	1100 mV	0 dB
Low	Open	-3.9 dB	1100 mV	0 dB
Low	High	-3.5 dB	900 mV	0 dB
Open	Low	-5.1 dB	900 mV	0 dB
Open	Open	-3.9 dB	1100 mV	6.0 dB
Open	High	-3.5 dB	900 mV	6.0 dB
High	Low	-5.3 dB	1100 mV	6.0 dB
High	Open	-5.1 dB	900 mV	6.0 dB
High	High	-5.3 dB	1100 mV	9.0 dB

OM13584

PTN5150A USB Type-C CC Logic and PTN36043 SuperSpeed Active Demux Application Board User's Manual Rev. 2.0 - 8/8/16

4.4 PTN5150A I²C Mode

By default, PTN5150A operates in non-I²C mode, and OUT1/OUT2/OUT3 pins are configured as outputs. In order to place PTN5150A in I²C mode, customers should configure pin 5 (ADR/CON_DET) with either a pull up resistor or a pull down resistor during power up, and OUT1/OUT2/OUT3 are re-configured as I²C_SDA/I²C_SCL/INTB functions.

Note that when operating in I²C mode, CON_DET output function is disabled by default. However, CON_DET is used by on-board discrete logic to enable/disable 5V power source and sink load switches, as well as VBus discharge circuit on the Type-C connector side. In order for these control circuits to operate correctly, customers should always write 0x00 to PTN5150A's internal address 0x09 to enable CON_DET output.

5. Different Operation Modes

PTN5150A/PTN36043 application board can be configured to operate in either one of the following configurations.

- Host (DFP) Mode – connect to a host PC via a standard A-A cable (cables are not provided), and connect to a device via a USB-Type-C to Type-A adapter.

In this mode, the demo board can be powered by the USB3 host, and 5V source load switch (U2) is enabled to pass VBus power from Type-A side to Type-C side.



- Device (UFP) Mode – connect to a host PC (such as Macbook or Chromebook) via a standard type-C cable, and connect to a device (such as thumb drive) via on-board Type-A receptacle.

In this mode, the demo board can be powered by the USB3 Type-C host, and 5V sink load switch (U5) is enabled to pass VBus power from Type-C side to Type-A side.

OM13584

PTN5150A USB Type-C CC Logic and PTN36043 SuperSpeed
Active Demux Application Board User's Manual
Rev. 2.0 - 8/8/16

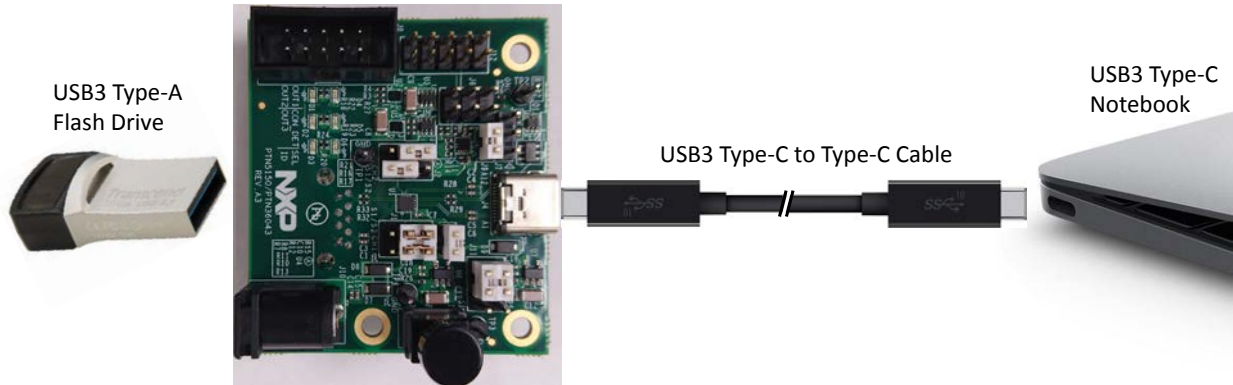

6. Conclusion

Using PTN5150A/PTN36043 application board, customer can validate most of the functions on both USB3 redriver for type-C application, and also CC logic chip for orientation detection. On board load-switches can be enabled/disabled based on the detecting status of PTN5150A through simple discrete logic without any firmware control.

Данный компонент на территории Российской Федерации

Вы можете приобрести в компании MosChip.

Для оперативного оформления запроса Вам необходимо перейти по данной ссылке:

<http://moschip.ru/get-element>

Вы можете разместить у нас заказ для любого Вашего проекта, будь то серийное производство или разработка единичного прибора.

В нашем ассортименте представлены ведущие мировые производители активных и пассивных электронных компонентов.

Нашей специализацией является поставка электронной компонентной базы двойного назначения, продукции таких производителей как XILINX, Intel (ex.ALTERA), Vicor, Microchip, Texas Instruments, Analog Devices, Mini-Circuits, Amphenol, Glenair.

Сотрудничество с глобальными дистрибьюторами электронных компонентов, предоставляет возможность заказывать и получать с международных складов практически любой перечень компонентов в оптимальные для Вас сроки.

На всех этапах разработки и производства наши партнеры могут получить квалифицированную поддержку опытных инженеров.

Система менеджмента качества компании отвечает требованиям в соответствии с ГОСТ Р ИСО 9001, ГОСТ РВ 0015-002 и ЭС РД 009

Офис по работе с юридическими лицами:

105318, г.Москва, ул.Щербаковская д.3, офис 1107, 1118, ДЦ «Щербаковский»

Телефон: +7 495 668-12-70 (многоканальный)

Факс: +7 495 668-12-70 (доб.304)

E-mail: info@moschip.ru

Skype отдела продаж:

moschip.ru

moschip.ru_4

moschip.ru_6

moschip.ru_9