

**FLUKE**®

## CLKT, CLKTO, CLV Infrared Window Installation Guide

### Introduction

The Infrared Window is a precision made accessory which, when accurately installed, will give years of trouble free service. Read and understand these instructions thoroughly before attempting to install the units.

All of the items in Table 1 are available from Fluke.

Table 1.

Model	Application	Type	Size
CLKT	Outdoor	3, 12	2", 3", 4"
CLKTO, CLV	Indoor	1	3"

PN 3783652  
June 2010 Rev.1, 3/11  
© 2010-11 Fluke Corporation. Product specifications are subject to change without notice. All rights reserved. Printed in UK.

### How to Contact Fluke

To contact Fluke, call one of the following telephone numbers:

- Technical Support USA: 1-800-44-FLUKE (1-800-443-5853)
- Calibration/Repair USA: 1-888-99-FLUKE (1-888-993-5853)
- Canada: 1-800-36-FLUKE (1-800-363-5853)
- Europe: +31 402-675-200
- Japan: +81-3-3434-0181
- Singapore: +65-738-5655
- Anywhere in the world: +1-425-446-5500

Or, visit Fluke's website at <http://www.fluke.com/irwindows>.

To view, print, or download the latest manual supplement, visit <http://us.fluke.com/usen/support/manuals>.

### Safety Information



**Warning**

To prevent damage or injury:

- Follow these instructions.
- Comply with local and national safety requirements when working in hazardous locations.
- Wear appropriate eye and ear protection.

### Before You Start

The installation may be carried out by using either an electro-hydraulic hole punch (Figure 1, Item 1) or a circular hole saw (Figure 2, Item 1).

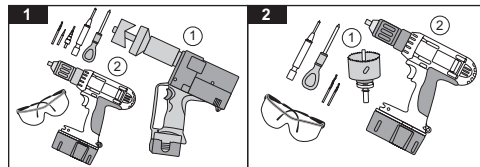

Tools required:

1. Electro-hydraulic punch (Figure 1) or hole saw (Figure 2)
2. Drilling machine
3. Conedrill
4. Pozidrive screwdriver
5. Center punch
6. 6 mm (1/4") high-speed twist drill
7. Tapping drill:
  - for 50 mm (2") units use 2.78 mm (7/64")
  - for 75 mm (3") units use 3.57 mm (9/64")
  - for 100 mm (4") units use 3.57 mm (9/64")
8. Digital vernier calipers.

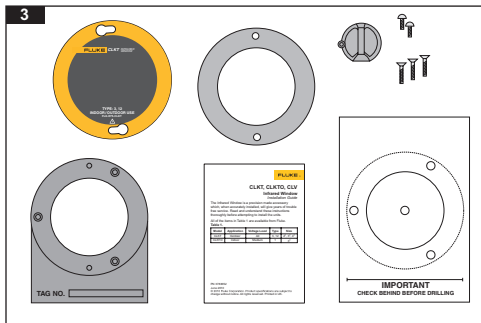

## Getting Started

### Step 1: Unpack and Check

When your Infrared Window arrives, carefully unpack the unit.

Remove the two front security screws and lay out the components. Check that you have all of the parts (Figure 3).

1. Security screws (2)
2. Security cover (1)
3. 2-hole gasket (1)
4. Fixing screws (various)
5. Drilling template (1)

6. Installation instructions (1)

7. Mounting frame (1)

### Step 2: Fit the Drilling Template onto a Flat Surface

Having decided on the correct position for the unit, select the drilling template. Peel off the back and stick to the panel with the wording horizontal (Figure 4).

### Step 3: Center Punch

Using the center punch, punch the fixing holes and center hole as marked (Figure 5).

### Step 4: Drill Center Hole

Using the 6 mm (1/4") twist drill, drill out the center hole (B) (Figure 6).

- For 50 mm (2") unit, proceed to step 5.
- For 75 mm (3") and 100 mm (4") units, proceed to step 6.

### Step 5: Drill Fixing Holes

Using the 2.78 mm (7/64") twist drill, drill out the fixing holes (Figure 7).

- If using hole saws, proceed to step 7(A).
- If using the hole punch, proceed to step 8(A).

### Step 6: Drill Fixing Holes

Using the 3.57 mm (9/64") twist drill, drill out the fixing holes (Figure 8).

- If using hole saws, proceed to step 7(A).
- If using the hole punch, proceed to step 8(A).

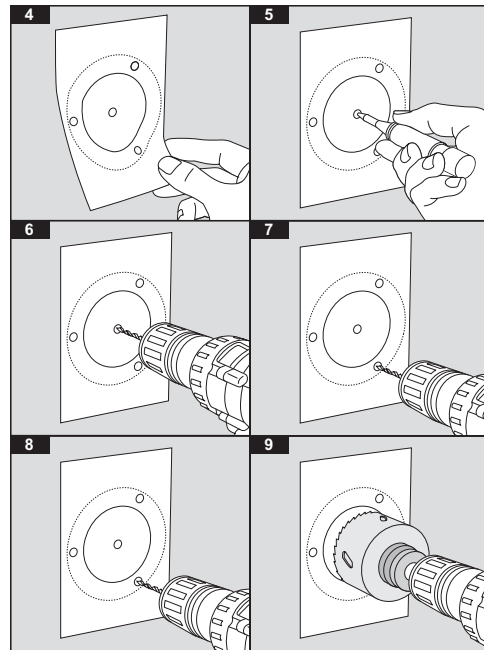

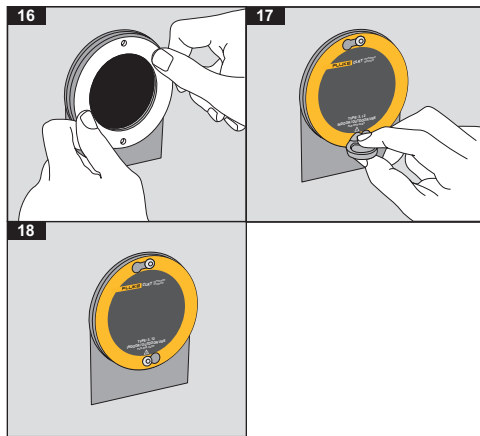
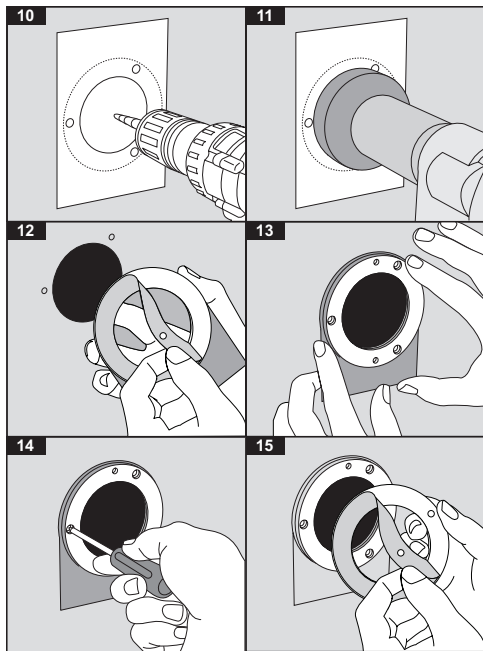

**Step 7(A): Enlarging the Center Hole (Hole Saw)**

From Table 2, select the correct size of hole saw. Proceed to step 7(B).

**Table 2.**

Infrared Window Size	Hole Saw Size
50 mm (2")	43 mm (1-3/4")
75 mm (3")	68 mm (2-5/8")
100 mm (4")	93 mm (3-5/8")

**Step 7(B): Enlarging the Center Hole (Hole Saw)**

Using the 6 mm (1/4") hole as a pilot hole, enlarge the center hole using the selected hole saw (Figure 9). Deburr all of the holes and treat as required. Proceed to step 9.

**Step 8(A): Enlarging the Center Hole (Hole Punch)**

Refer to the hole punch manual and follow all safety procedures.

From Table 3, select the correct drawbar/punch/die/kwik stepper combination.

Using the Kwik Stepper, enlarge the 6mm center hole (Figure 10) to the size shown in Table 3. Proceed to step 8(B).

**Table 3.**

Infrared Window Size	Size	K/Step	Greenlee Punch/Die/PN
50 mm (2")	43.2 mm/1.7"	20 mm/0.8"	06974/04013
75 mm (3")	69.9 mm/2.75"	20 mm/0.8"	04247/04246
100 mm (4")	92 mm/3.62"	20 mm/0.8"	Hole Saw Only

**Step 8(B): Enlarging the Center Hole (Hole Punch)**

Referring to Table 3, and following the instructions in the hole punch manual, punch out the center hole (Figure 11).

**Step 9: De-Burr the Holes, Remove any Shavings and the Self Adhesive Template**

Degrease the front panel.

**Step 10: Fix Infrared Window**

Peel off the protective cover from the rear panel gasket on the Infrared Window's mounting frame (Figure 12).

Align the fixing holes and firmly press the Infrared Window into place (Figure 13).

Using the correct sized screwdriver and the countersunk screws provided, fix back the Infrared Window (Figure 14).

Gradually advance each fixing until the gasket is seen to compress evenly. Refer to Table 4.

**Step 11 - Fitting Security Cover**

Peel off the cover from the 2-hole gasket (Figure 15).

Align the gasket with the two fixing holes positioned vertically and press the gasket into position (Figure 16).

Fit the security cover using the two security screws provided (Figure 17).

The Infrared Window is ready to use. Remember to remove the cover before imaging (Figure 18).

**Gasket Compression Table**

Tighten tapite screws until gasket compresses as listed in Table 4.

*Note*

*Take all measurements with digital vernier calipers.*

**Table 4.**

<b>2" Compression Table</b>			
<b>Standard Gasket</b>		<b>Premier Gasket</b>	
<b>U/C</b>	<b>C</b>	<b>U/C</b>	<b>C</b>
16.8 mm	16.3 mm	16.3 mm	15.0 mm
0.663"	0.643"	0.643"	0.591"
<b>3" Compression Table</b>			
16.8 mm	16.3 mm	16.3 mm	15.0 mm
0.663"	0.643"	0.643"	0.591"
<b>4" Compression Table</b>			
20.4 mm	19.9 mm	N/A	N/A
0.805"	0.784"	N/A	N/A
U/C = Overall dimension - Exterior of security cover to front face of the panel with gasket uncompressed.			
C = Overall dimension - Exterior of security cover to front face of the panel with gasket compressed.			

## Данный компонент на территории Российской Федерации

### Вы можете приобрести в компании MosChip.

Для оперативного оформления запроса Вам необходимо перейти по данной ссылке:

<http://moschip.ru/get-element>

Вы можете разместить у нас заказ для любого Вашего проекта, будь то серийное производство или разработка единичного прибора.

В нашем ассортименте представлены ведущие мировые производители активных и пассивных электронных компонентов.

Нашей специализацией является поставка электронной компонентной базы двойного назначения, продукции таких производителей как XILINX, Intel (ex.ALTERA), Vicor, Microchip, Texas Instruments, Analog Devices, Mini-Circuits, Amphenol, Glenair.

Сотрудничество с глобальными дистрибьюторами электронных компонентов, предоставляет возможность заказывать и получать с международных складов практически любой перечень компонентов в оптимальные для Вас сроки.

На всех этапах разработки и производства наши партнеры могут получить квалифицированную поддержку опытных инженеров.

Система менеджмента качества компании отвечает требованиям в соответствии с ГОСТ Р ИСО 9001, ГОСТ РВ 0015-002 и ЭС РД 009

### Офис по работе с юридическими лицами:

105318, г.Москва, ул.Щербаковская д.3, офис 1107, 1118, ДЦ «Щербаковский»

Телефон: +7 495 668-12-70 (многоканальный)

Факс: +7 495 668-12-70 (доб.304)

E-mail: [info@moschip.ru](mailto:info@moschip.ru)

Skype отдела продаж:

moschip.ru

moschip.ru\_4

moschip.ru\_6

moschip.ru\_9