

# Bolt Style EMI Filters

## SA Series – 4-40 Thread - Epoxy Sealed – Circuits Available – C & L

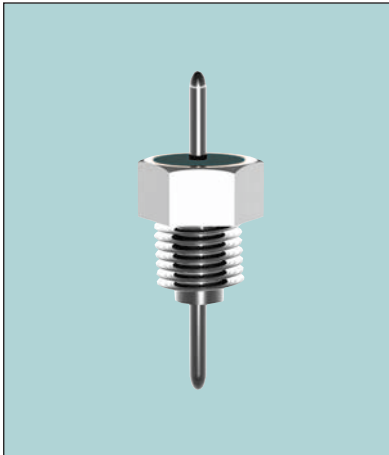

### APPLICATIONS

The SA series provides effective filtering in the RF and MICROWAVE frequency spectrums from 10 MHz through 26 GHz. Designed for mounting in a tapped bulkhead or with the standard nut and lockwasher provided, it is ideal for high impedance circuits where large capacitance values are not practical. In the “L” section version an internal ferrite bead

element provides both inductance and series resistance (lossy characteristic) which improves insertion loss and provides superior transient performance. The SA series comes with a standard .020 diameter beryllium copper lead. Alternate lead lengths, diameters of .016 or .026 and alternate materials in steel or half-hard copper are available.

### CHARACTERISTICS

- Meets or exceeds the applicable portions of MIL-F-28861/6. See QPL listings.
- Smallest screwbody filter available.
- Features rugged monolithic discoidal capacitor construction.
- Epoxy seal on both ends.

### SPECIFICATIONS

1. Plating: Silver standard – Electro-tin or gold available
2. Material:
  - Case: Cold rolled steel
  - Leads: Beryllium copper (steel or half/hard copper leads available)
3. Operating Temperature Range: -55°C to +125°C
4. Insulation Resistance:
  - At 25°C: 1,000 megohm-microfarad min., or 100,000 megohms min., whichever is less
  - At 125°C: 100 megohm-microfarad min., or 10,000 megohms min., whichever is less
5. Dielectric Withstanding Voltage (DWW):
  - R-level designs: 2.0 times rated DC voltage
  - Class B, Class S designs: 2.5 times rated DC voltage
6. DC Resistance (DCR): .02 ohm, maximum
7. Dissipation Factor (DF): 3% maximum
8. Rated DC Current: 5 Amps, maximum
9. Recommended Mounting Torque: 32 oz-in. ± 4 oz-in.
10. Supplied with mounting nut and lockwasher - See Filter Design Guide Screw and Locking Washer Table
11. Insertion Loss for the “C” and “L” sections are equivalent due to the saturation characteristic of the ferrite bead element at rated current. At lower currents the “L” becomes much more effective.

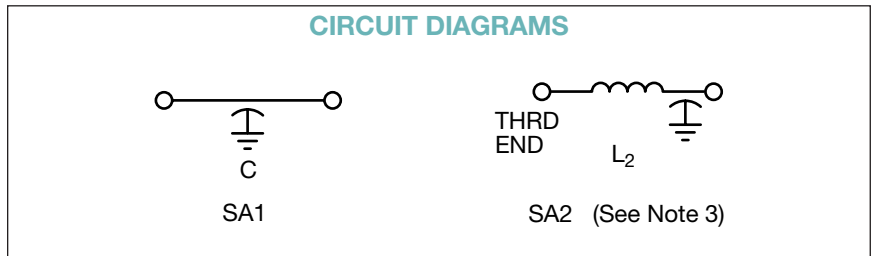
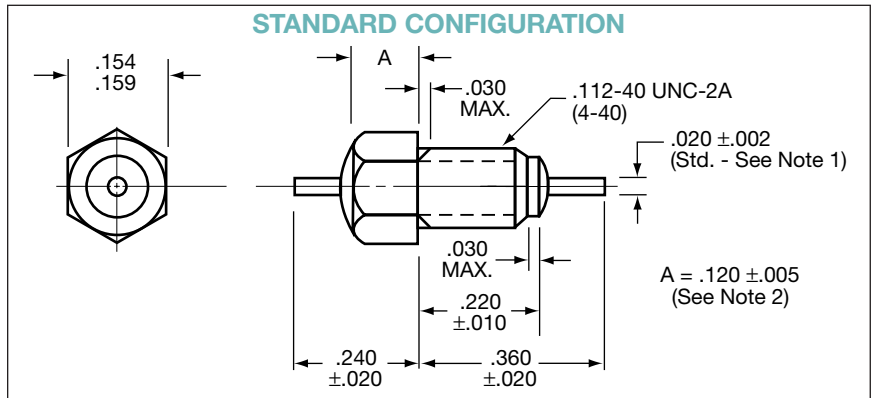

millimeters (inches)	
0.05 (.002)	3.05 (.120)
0.13 (.005)	3.68 (.145)
0.25 (.010)	3.91 (.154)
0.41 (.016)	4.04 (.159)
0.51 (.020)	5.59 (.220)
0.66 (.026)	6.10 (.240)
0.76 (.030)	9.14 (.360)
2.84 (.112)	—

(See Note 4)

#### Notes:

1. Standard catalog designs have .020" dia. lead. MIL-F-28861/6 calls for .026" dia. .026" dia. will not be supplied unless specified.
2. "A" dimension of .120 ± .005 will satisfy M28861/6-003 requirement for .145 ± .030. All "SA" series are supplied A = .120 ± .005.
3. All SA2 L-Section Filters have inductor (bead) at threaded end.
4. Metric equivalent dimensions given for information only.

# Bolt Style EMI Filters

## SA Series – 4-40 Thread - Epoxy Sealed – Circuits Available – C & L



### SPECIFICATIONS

AVX P/N	CKT	CAP <sup>1</sup>	DC Voltage	DCR	Insertion Loss <sup>2</sup> Per MIL-STD-220, +25°C					
					1 MHz	10 MHz	100 MHz	200 MHz	1 GHz	10 GHz
SA1C1-102	C	1000	50	.02	–	4	20	25	25	55
SA1C1-502	C	5000	50	.02	–	15	34	41	42	55
SA1C1-103	C	.01	50	.02	4	21	35	42	50	70
SA1C1-273	C	.027	50	.02	10	30	39	43	65	70
SA1C1-503	C	.05	50	.02	15	35	42	45	70	70
SA2C1-102	L2	1000	50	.02	–	4	20	27	30	60
SA2C1-502	L2	5000	50	.02	–	15	35	41	45	60
SA2C1-103	L2	.01	50	.02	4	21	35	44	50	70
SA2C1-273	L2	.027	50	.02	10	30	50	45	65	70
SA2C1-503	L2	.05	50	.02	15	37	45	45	70	70
SA1A1-102	C	1000	100	.02	–	4	20	25	25	55
SA1A1-502	C	5000	100	.02	–	15	35	41	42	55
SA1A1-103	C	.01	100	.02	4	21	35	42	50	70
SA1A1-273	C	.027	100	.02	10	30	39	43	65	70
SA1A1-453	C	.045	100	.02	14	35	42	45	70	70
SA2A1-102	L2	1000	100	.02	–	4	20	27	30	60
SA2A1-502	L2	5000	100	.02	–	15	35	41	45	60
SA2A1-103	L2	.01	100	.02	4	21	35	44	50	70
SA2A1-273	L2	.027	100	.02	10	30	50	45	70	70
SA2A1-453	L2	.045	100	.02	14	37	45	45	70	70
SA1B1-102	C	1000	200	.02	–	4	20	25	25	55
SA1B1-502	C	5000	200	.02	–	15	34	41	42	55
SA1B1-103	C	.01	200	.02	4	21	35	42	50	70
SA2B1-102	L2	1000	200	.02	–	4	20	27	30	60
SA2B1-502	L2	5000	200	.02	–	15	35	41	45	60
SA2B1-103	L2	.01	200	.02	4	21	35	44	50	70

<sup>1</sup> Decimal point values indicate capacitance in microfarads.  
Non-decimal point values indicate capacitance in picofarads.

<sup>2</sup> Insertion loss limits are based on theoretical values.  
Actual measurements may vary due to internal capacitor  
resonances and other design constraints.

## Данный компонент на территории Российской Федерации

### Вы можете приобрести в компании MosChip.

Для оперативного оформления запроса Вам необходимо перейти по данной ссылке:

<http://moschip.ru/get-element>

Вы можете разместить у нас заказ для любого Вашего проекта, будь то серийное производство или разработка единичного прибора.

В нашем ассортименте представлены ведущие мировые производители активных и пассивных электронных компонентов.

Нашей специализацией является поставка электронной компонентной базы двойного назначения, продукции таких производителей как XILINX, Intel (ex.ALTERA), Vicor, Microchip, Texas Instruments, Analog Devices, Mini-Circuits, Amphenol, Glenair.

Сотрудничество с глобальными дистрибьюторами электронных компонентов, предоставляет возможность заказывать и получать с международных складов практически любой перечень компонентов в оптимальные для Вас сроки.

На всех этапах разработки и производства наши партнеры могут получить квалифицированную поддержку опытных инженеров.

Система менеджмента качества компании отвечает требованиям в соответствии с ГОСТ Р ИСО 9001, ГОСТ РВ 0015-002 и ЭС РД 009

### Офис по работе с юридическими лицами:

105318, г.Москва, ул.Щербаковская д.3, офис 1107, 1118, ДЦ «Щербаковский»

Телефон: +7 495 668-12-70 (многоканальный)

Факс: +7 495 668-12-70 (доб.304)

E-mail: [info@moschip.ru](mailto:info@moschip.ru)

Skype отдела продаж:

moschip.ru

moschip.ru\_4

moschip.ru\_6

moschip.ru\_9