

SMART Position Sensor, Rotary Configuration

Superior Measurement. Accurate. Reliable. Thinking.



DESCRIPTION

Honeywell's SMART Position Sensors are some of the most durable, adaptable, and lightweight absolute position sensors available in the industry, enabling highly accurate motion control and improving operation efficiency and safety.

Why is the SMART Position Sensor smart? SMART means that this is a sensor that can essentially think for itself. With the SMART position technology, Honeywell has utilized MR (magneto-resistive) technology through the ASIC (Application-Specific Integrated Circuit) at a level never before accomplished. The rotary configuration joins Honeywell's SMART Position Sensor family of proven linear and arc configurations.

The SMART Position Sensor, Rotary Configuration, is a non-contacting sensing solution for absolute position sensing with enhanced accuracy. It senses the position of a magnet relative to the sensor in a range of 0° to 360°.

Honeywell uses a patented combination of an ASIC and an array of MR sensors to accurately and reliably determine the position of a magnet collar attached to a rotating object so that the object's position can be determined or controlled. The output and the MR sensor sequence determine the nearest pair of MR sensors to the center of the magnet location. The output of these two MR sensors is then used to determine the position of the magnet between them.

The SMART Position Sensor, Rotary Configuration, fits on a 25,4 mm [1 in] shaft. A mounting tool fixture (purchased separately) provides repeatable installation.

VALUE PROPOSITIONS (★ = competitive differentiator)

- ★ **Non-contact design:** Eliminates mechanical failure mechanisms, reducing wear, which improves reliability and durability, and minimizes downtime
- ★ **Combined patented MR sensor and ASIC technology provides absolute position sensing:**
 - Helps OEMs reduce warranty costs because they don't have to replace worn or broken component parts
 - Helps end-users reduce downtime due to fewer calibration requirements
- ★ **No internal moving parts:** Automotive-grade potting makes the sensor more resistant to vibration, shock, and extreme temperatures, improving reliability
- ★ **Repeatable output:** Occurs within a 3,0 mm ±2,0 mm [0.118 in ±0.079 in] air gap between the sensor and magnet collar, expanding application opportunities
- **High accuracy:** Measures values down to 0.01°; better sensor accuracy can provide better system accuracy in the application
- ★ **IP67 and IP69K sealing:** Allows for use in harsh environments such as dust, immersion up to 1 m [39.37 in] of water for 30 minutes, and high pressure water sprays
- ★ **High shock and vibration resistance:** Allows for use in a wide variety of tough applications

FEATURES AND BENEFITS

- **Minimal signal error:** Exists up to 2,50 mm [0.10 in] of radial error, simplifying design-in
- **RoHS-compliant:** Materials meet Directive 2002/95/EC

SMART Position Sensor

POTENTIAL APPLICATIONS

Transportation:

- Steering angle
- Articulation angle
- Boom arm detection

Industrial:

- Solar panels
- Wind turbines

Table 1. Specifications¹

| Characteristic | Component | Parameter | Note |
|--|--|---|------------------------------------|
| Sensing range | sensor only | 360° | – |
| Resolution | | 0.01° | – |
| Supply voltage | | 12 Vdc to 30 Vdc | – |
| Output | | 4 mA to 20 mA | – |
| Supply current | | 90 mA max. | – |
| Linearity: 25 °C [77 °F] TC: >85 °C [158 °F] | | -0.03 %FS min., 0.030 %FS max. 0.0011 %FS/°C | 2, 4, 7 |
| Offset: 25 °C [77 °F] TC: >85 °C [158 °F] | | -0.044 %FS min., -0.011 %FS typ., 0.022 %FS max. 0.0033 %FS/°C | 3, 4, 5, 7 |
| Accuracy | | -0.069 %FS min., 0.069 %FS max. | 4 |
| Sensitivity: 25 °C [77 °F] TC: >85 °C [158 °F] | | 44.43 µA/° min., 44.43 µA/° typ., 44.48 µA/° max. 80 ppm/°C | 6, 7 |
| Reverse polarity | | -12 Vdc to -30 Vdc | – |
| Initial startup time | | 130 ms typ. | – |
| Termination | | M12 connector, male 5 pin | – |
| Operating temperature | | sensor and magnet collar | -40 °C to 85 °C [-40 °F to 185 °F] |
| Storage temperature | -40 °C to 150 °C [-40 °F to 302 °F] | | – |
| Air gap | 3,0 mm ±2,0 mm [0.118 in ±0.079 in] typ. | | – |
| Sealing | IP67, IP69K | | – |
| Shock | 50 G half sine wave with 11 ms duration | | – |
| Vibration | 20 G from 10 Hz to 2000 Hz | | – |
| Housing material | aluminum with powder coating | | – |
| Approvals | CE | | – |
| Mounting: screws recommended torque | M5 or UNC 10-24 5 N m to 7 N m [44.25 in lb to 61.95 in lb] | | – |
| Material | magnet only | | neodymium (sintered NdFeB) |
| Strength | only | 3700 Gauss | – |

Notes:

1. Specifications are based on a non-ferrous shaft.
2. Linearity: Deviations from a best fit straight line through the output, expressed as a percentage of the full scale signal range (% of 16 mA).
3. Accuracy: Deviations from the ideal output line expressed as a percentage of the full scale signal range (% of 16 mA).
4. %FS: Error expressed as a percentage of the output span of the sensor (% of 16 mA).
5. Offset: Deviation from the ideal output at the minimum input condition, expressed as a percentage of the full scale signal range (% of 16 mA).
6. Sensitivity: The slope of the output signal vs magnet travel, expressed as µA of output per degree of travel.
7. TC: Temperature coefficient of a given parameter, as a percentage of the full scale signal range (% of 16 mA) per degree of temperature rise from 25 °C [77 °F].

Rotary Configuration

Table 2. % Linearity

| | | Radial Error (mm) | | | | | | | | | |
|--------------------|----|-------------------|-------|-------|-------|-------|-------|-------|-------|-------|-------|
| | | 0 | 0.05 | 0.1 | 0.25 | 0.5 | 0.75 | 1 | 1.5 | 2 | 2.5 |
| Air Gap Error (mm) | -2 | -0.005 | 0.001 | 0.007 | 0.027 | 0.066 | 0.113 | 0.166 | 0.294 | 0.450 | 0.635 |
| | -1 | -0.002 | 0.003 | 0.008 | 0.025 | 0.060 | 0.101 | 0.150 | 0.269 | 0.417 | 0.593 |
| | 0 | 0.000 | 0.004 | 0.008 | 0.023 | 0.053 | 0.090 | 0.135 | 0.245 | 0.383 | 0.550 |
| | 1 | 0.002 | 0.005 | 0.009 | 0.021 | 0.047 | 0.079 | 0.119 | 0.220 | 0.350 | 0.508 |
| | 2 | 0.005 | 0.007 | 0.009 | 0.019 | 0.040 | 0.068 | 0.104 | 0.196 | 0.317 | 0.466 |
| | 3 | 0.007 | 0.008 | 0.010 | 0.017 | 0.033 | 0.057 | 0.088 | 0.172 | 0.284 | 0.424 |

Table 3. % Accuracy

| | | Radial Error (mm) | | | | | | | | | |
|--------------------|----|-------------------|-------|-------|-------|-------|-------|-------|-------|-------|-------|
| | | 0 | 0.05 | 0.1 | 0.25 | 0.5 | 0.75 | 1 | 1.5 | 2 | 2.5 |
| Air Gap Error (mm) | -2 | 0 | 0.006 | 0.012 | 0.033 | 0.076 | 0.129 | 0.191 | 0.263 | 0.538 | 0.770 |
| | -1 | 0 | 0.005 | 0.011 | 0.029 | 0.069 | 0.118 | 0.176 | 0.245 | 0.509 | 0.733 |
| | 0 | 0 | 0.004 | 0.009 | 0.026 | 0.061 | 0.106 | 0.162 | 0.226 | 0.479 | 0.697 |
| | 1 | 0 | 0.004 | 0.008 | 0.022 | 0.054 | 0.095 | 0.147 | 0.208 | 0.450 | 0.660 |
| | 2 | 0 | 0.003 | 0.006 | 0.018 | 0.047 | 0.084 | 0.132 | 0.190 | 0.420 | 0.623 |
| | 3 | 0 | 0.002 | 0.005 | 0.015 | 0.039 | 0.073 | 0.117 | 0.171 | 0.391 | 0.586 |

Figure 1. Sensor

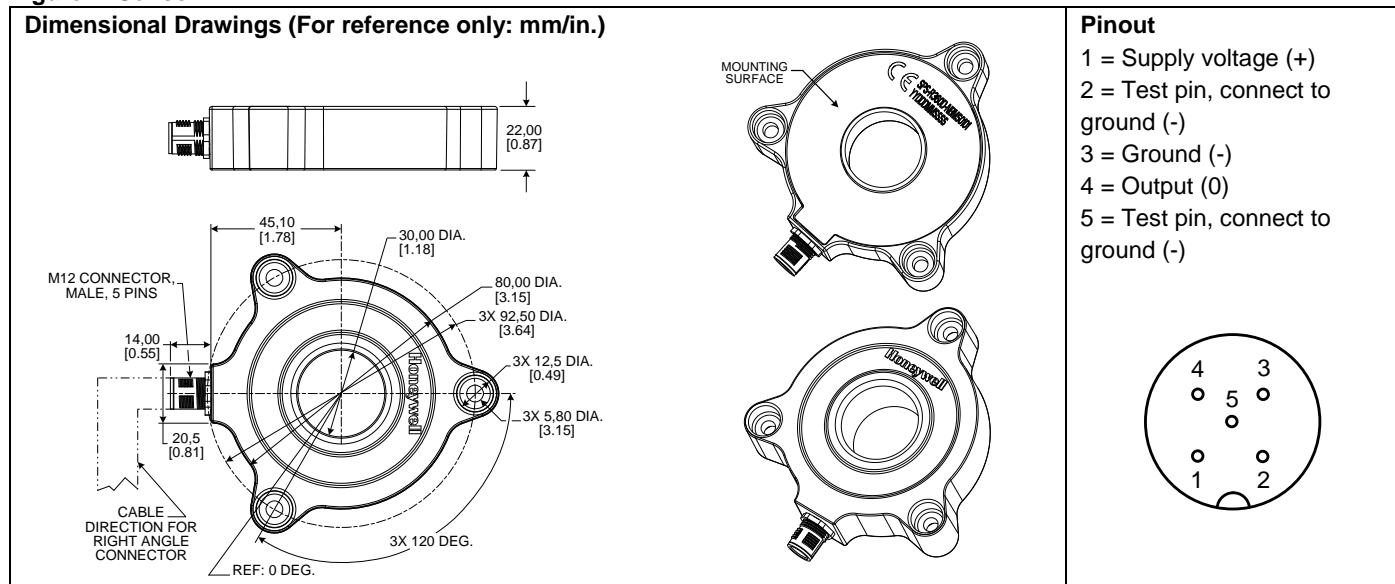
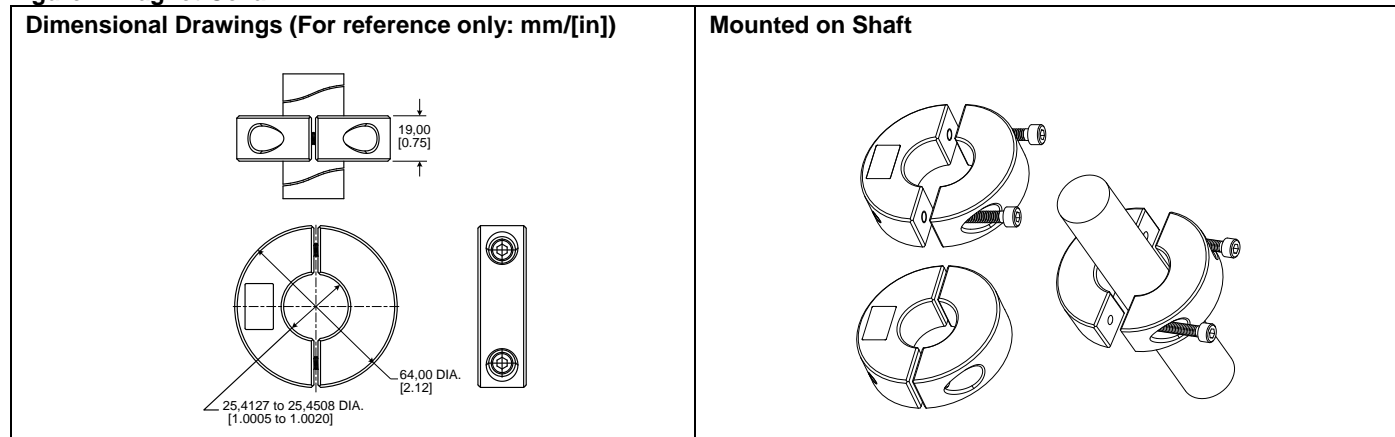

Figure 2. Magnet Collar



SMART Position Sensor

NOTICE

Stationary ferrous material often creates an initial offset upon installation. If the stationary ferrous material never moves in relation to the sensor after the installation, and the environment remains ferrous-free, performance should be repeatable. Ensure the sensor is tested in the application.

Figure 3. Assembly Tools

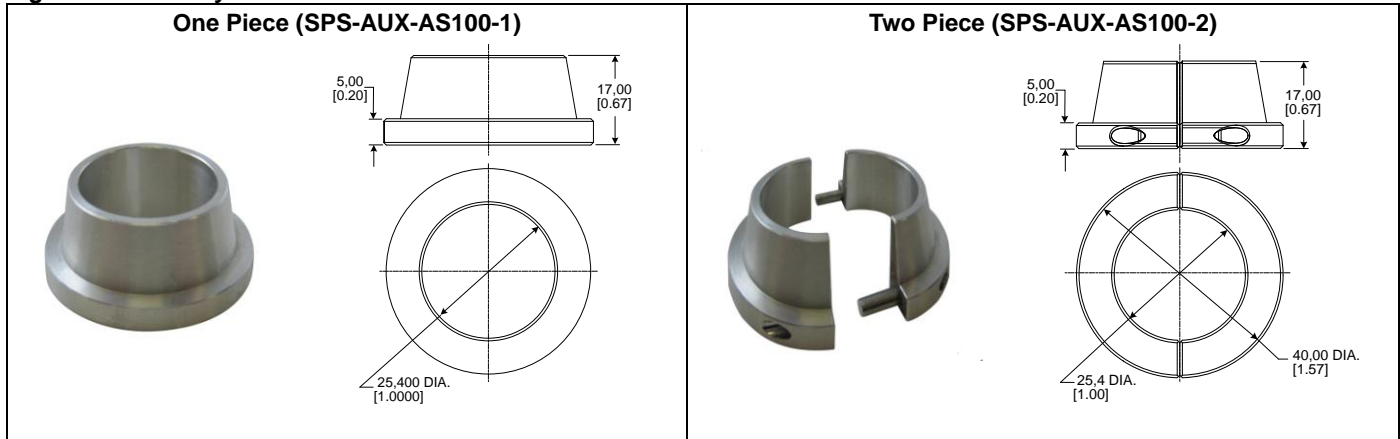

NOTICE

ASSEMBLY TOOL USE

Honeywell recommends using an assembly tool to help align the magnetic axis of rotation to the inside diameter of the Sensor.

Assembly Tool Use

1. Place the sensor over the shaft with its epoxy side facing the mating surface of the mounting plate.
2. Loosely assemble the mounting screws in the sensor.
3. Install the assembly tool on the shaft.
4. Push the assembly tool into the rotary sensor to center on the shaft.
5. Tighten the sensor mounting screws while maintaining pressure on the assembly tool.
6. Remove the assembly tool.

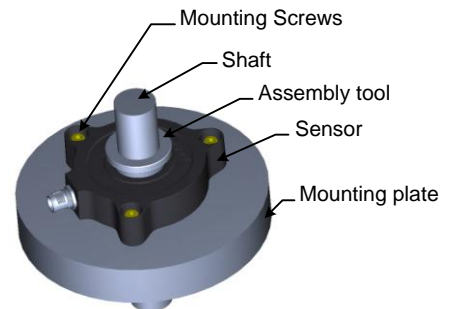

Rotary Configuration

Figure 4. Sensor Mounting Examples

General

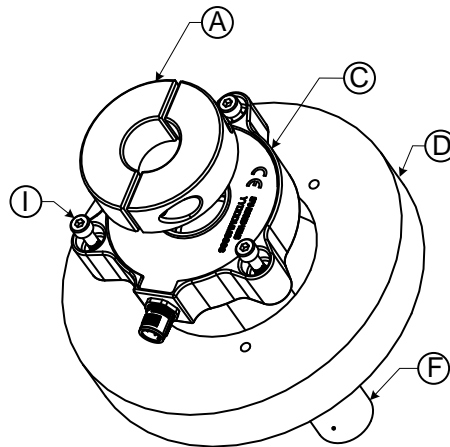

Through Shaft

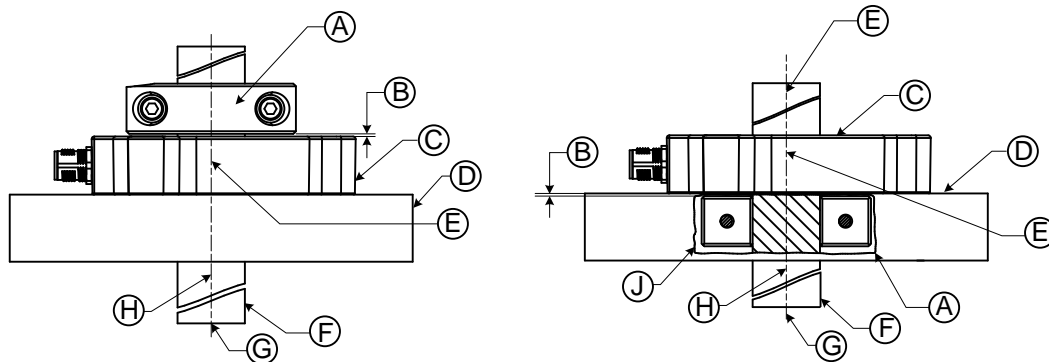



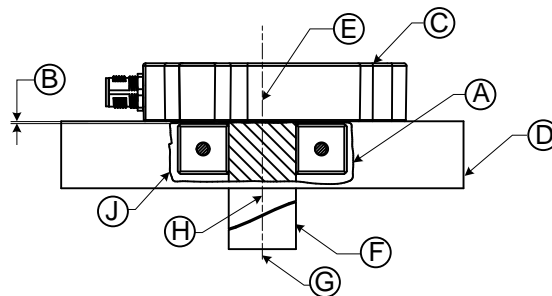

Blind Shaft



- A** = Magnet collar (purchased separately)
- B** = Air gap (3,0 mm \pm 2,0 mm [0.118 in \pm 0.079 in] typ.)
- C** = Sensor
- D** = Mounting plate (customer supplied - provides surface to mount sensor)
- E** = Sensor axis
- F** = Shaft (customer supplied - provides shaft to attach magnet actuator)
- G** = Radial alignment (see Table 1)
- H** = Shaft axis
- I** = Mounting screws (customer supplied - M5 or UNC 10-24)
- J** = Recess

Order Guide

| Catalog Listing | Description | |
|------------------------------|--|---|
| SPS-R360D-NBMS0101 | SMART Position Sensor, rotary configuration, 360° sensing range, 4 mA to 20 mA output (magnet collar not included) |  |
| SPS-MAG-002 ¹ | Magnet collar for 25,4 mm [1 in] corresponding shaft diameter (sold separately) |  |
| SPS-AUX-AS100-1 ¹ | Assembly tool, one piece, 25,4 mm [1 in], aluminum (sold separately) |  |
| SPS-AUX-AS100-2 ¹ | Assembly tool, two piece, 25,4 mm [1 in], aluminum (sold separately) |  |

Note 1: Custom sizes are available if volume thresholds are met.

WARNING

PERSONAL INJURY

DO NOT USE these products as safety or emergency stop devices or in any other application where failure of the product could result in personal injury.

Failure to comply with these instructions could result in death or serious injury.

WARRANTY/REMEDY

Honeywell warrants goods of its manufacture as being free of defective materials and faulty workmanship. Honeywell's standard product warranty applies unless agreed to otherwise by Honeywell in writing; please refer to your order acknowledgement or consult your local sales office for specific warranty details. If warranted goods are returned to Honeywell during the period of coverage, Honeywell will repair or replace, at its option, without charge those items it finds defective. **The foregoing is buyer's sole remedy and is in lieu of all other warranties, expressed or implied, including those of merchantability and fitness for a particular purpose. In no event shall Honeywell be liable for consequential, special, or indirect damages.**

While we provide application assistance personally, through our literature and the Honeywell web site, it is up to the customer to determine the suitability of the product in the application.

Specifications may change without notice. The information we supply is believed to be accurate and reliable as of this printing. However, we assume no responsibility for its use.

WARNING

MISUSE OF DOCUMENTATION

- The information presented in this product sheet is for reference only. Do not use this document as a product installation guide.
- Complete installation, operation, and maintenance information is provided in the instructions supplied with each product.

Failure to comply with these instructions could result in death or serious injury.

SALES AND SERVICE

Honeywell serves its customers through a worldwide network of sales offices, representatives and distributors. For application assistance, current specifications, pricing or name of the nearest Authorized Distributor, contact your local sales office or:

E-mail: info.sc@honeywell.com

Internet: www.honeywell.com/sensing

Phone and Fax:

| | |
|---------------|---|
| Asia Pacific | +65 6355-2828 +65 6445-3033 Fax |
| Europe | +44 (0) 1698 481481 +44 (0) 1698 481676 Fax |
| Latin America | +1-305-805-8188 +1-305-883-8257 Fax |
| USA/Canada | +1-800-537-6945 +1-815-235-6847 +1-815-235-6545 Fax |

Sensing and Control
Honeywell
1985 Douglas Drive North
Golden Valley, MN 55422
www.honeywell.com

005948-2-EN
July 2012

Copyright © 2012 Honeywell International Inc. All rights reserved.

Honeywell

Данный компонент на территории Российской Федерации

Вы можете приобрести в компании MosChip.

Для оперативного оформления запроса Вам необходимо перейти по данной ссылке:

<http://moschip.ru/get-element>

Вы можете разместить у нас заказ для любого Вашего проекта, будь то серийное производство или разработка единичного прибора.

В нашем ассортименте представлены ведущие мировые производители активных и пассивных электронных компонентов.

Нашей специализацией является поставка электронной компонентной базы двойного назначения, продукции таких производителей как XILINX, Intel (ex.ALTERA), Vicor, Microchip, Texas Instruments, Analog Devices, Mini-Circuits, Amphenol, Glenair.

Сотрудничество с глобальными дистрибьюторами электронных компонентов, предоставляет возможность заказывать и получать с международных складов практически любой перечень компонентов в оптимальные для Вас сроки.

На всех этапах разработки и производства наши партнеры могут получить квалифицированную поддержку опытных инженеров.

Система менеджмента качества компании отвечает требованиям в соответствии с ГОСТ Р ИСО 9001, ГОСТ РВ 0015-002 и ЭС РД 009

Офис по работе с юридическими лицами:

105318, г.Москва, ул.Щербаковская д.3, офис 1107, 1118, ДЦ «Щербаковский»

Телефон: +7 495 668-12-70 (многоканальный)

Факс: +7 495 668-12-70 (доб.304)

E-mail: info@moschip.ru

Skype отдела продаж:

moschip.ru

moschip.ru_4

moschip.ru_6

moschip.ru_9