

GMT HAND TOOL RATCHET ADJUSTMENT (WHERE APPLICABLE)

DMC DANIELS
MANUFACTURING
CORPORATION
DATASHEET

THIS HAND TOOL MUST NOT BE USED IN ANY POWERED "PRESS" AS DEFINED BY OSHA CFR 1910.211 (46)

SEE PAGE 3 FOR IMPORTANT INFORMATION CONCERNING LIMITED WARRANTY, AND LIMITATION OF LIABILITY.

Construct a Calibration Fixture and position tool assembly as shown in Figure 1. Compress handles and gage by turning the drive screw clockwise. Note the compression force required for the pawl to release from the last tooth of the ratchet. To adjust ratchet, tool must be in open position. Using a 1/2 inch wrench, loosen the screw cap about 1/2 a turn. Next, turn the eccentric screw clockwise to increase the compression force (causing a tighter crimp) and counter clockwise to decrease the compression force. While holding eccentric screw in desired position, tighten screw cap about 1/8 turn after snug. **CAUTION: DO NOT OVER TIGHTEN SCREW CAP – TOOL WILL JAM.** Repeat this procedure until desired force of 40 ± 5 lb. is achieved.

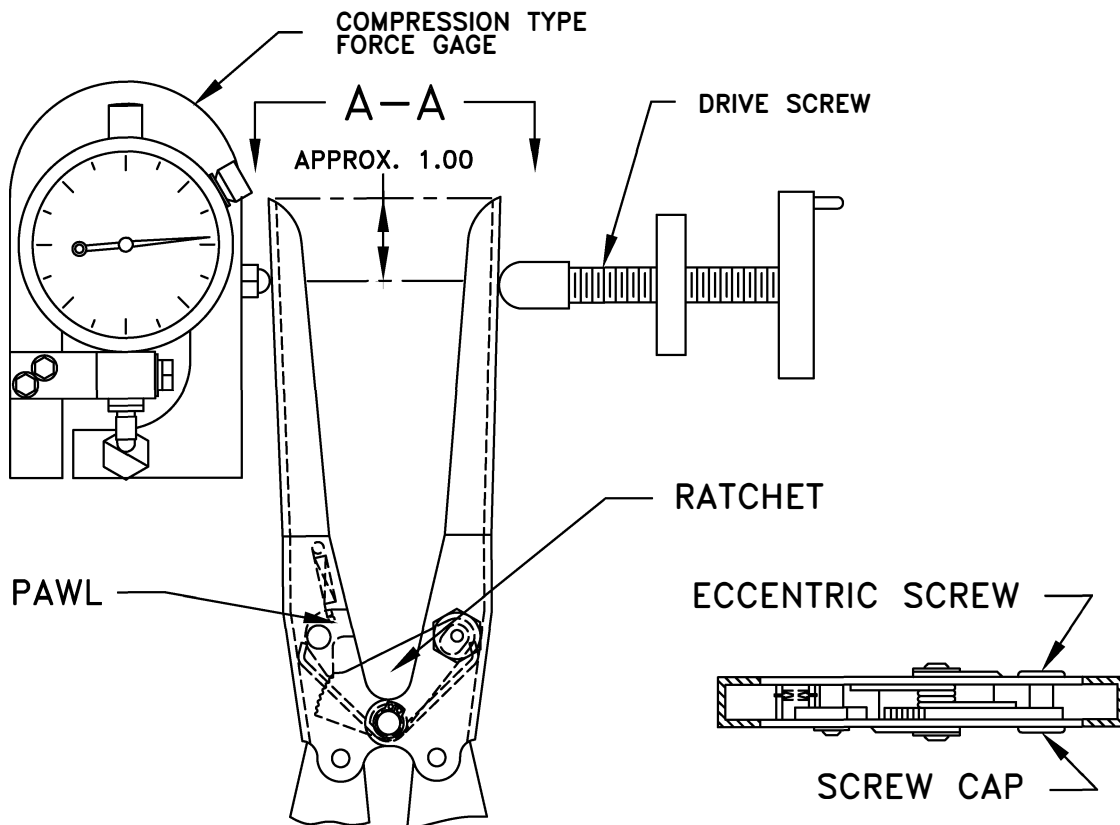

FIGURE 1

**VIEW A-A
FIGURE 2**

DAILY MAINTENANCE

A properly crimped terminal is controlled by the following maintenance and inspection procedures.

- A. Clean all dust, dirt, moisture and other foreign matter from the crimp jaws that could damage the crimp area of the dies.
- B. The pivot pin and ratched pawl bearing surface should be lubricated to ensure a smooth operation.
- C. When storing the tool, close the handles until the ratchet pawl is about to be released from the last tooth of the ratchet. This will help prevent the dies from being damaged.

PERIODIC INSPECTION PROCEDURE

Visual inspections should be performed on the tool based on the amount of use, working conditions and operator skill and care.

- A. Clean tool die area with solvent or brush.
- B. Check crimp area of dies for damage.
- C. If tool jams or locks, check the ratchet for dirt and lubrication.

CARE OF TOOL

It is a good practice to keep indenter tips free of residual color band deposits and other debris. A small wire brush may be used for this purpose.

We strongly recommend that you:

1. DO NOT immerse tools in cleaning solution.
2. DO NOT spray oil into tool to lubricate except as noted in Section B under Daily Manitenance.
3. DO NOT attempt to disassemble tool or make repairs.

This is a precision hand crimping tool and should be handled as such.

DMC offers complete refurbishing and recalibration services.

DMC engineers and manufactures complete tool kits to satisfy individual customer requirements, such as total aircraft support, general shop maintenance or production, on board ship and vehicle service, etc.

LIMITATION OF LIABILITY

DANIELS MANUFACTURING CORPORATION IS NOT LIABLE FOR CONSEQUENTIAL OR SPECIAL DAMAGES OF ANY NATURE OR KIND RESULTING FROM THE USE, OR MISUSE, OF ANY OF ITS PRODUCTS. OWNERS AND USERS OF DMC PRODUCTS ASSUME FULL RESPONSIBILITY FOR INSTRUCTING THEIR EMPLOYEES IN THE PROPER AND SAFE USE OF SUCH PRODUCTS.

LIMITED WARRANTY

DMC (Daniels Manufacturing Corporation) warrants each new product sold by it to be free from defects in material and workmanship under normal use and service. DMC's obligation under this warranty is limited to the free correction or, at DMC's option, the refund of the purchase price of any such product which proves defective in normal service within ninety (90) days after delivery to the first user, provided that the product is returned to DMC with all transportation charges prepaid and which shall appear to DMC's satisfaction, after DMC's inspection, to have been defective in material or workmanship, it being understood that DMC products are not consumer products. This warranty shall not cover any damage to any product which, in the opinion of DMC, was caused by normal wear, misuse, improper operation, tampering, neglect or accident. This warranty is in lieu of all other warranties express or implied. No warranty, express or implied, is made or authorized to be made or assumed with respect to products of Daniels Manufacturing Corporation other than those herein set forth.

Данный компонент на территории Российской Федерации

Вы можете приобрести в компании MosChip.

Для оперативного оформления запроса Вам необходимо перейти по данной ссылке:

<http://moschip.ru/get-element>

Вы можете разместить у нас заказ для любого Вашего проекта, будь то серийное производство или разработка единичного прибора.

В нашем ассортименте представлены ведущие мировые производители активных и пассивных электронных компонентов.

Нашей специализацией является поставка электронной компонентной базы двойного назначения, продукции таких производителей как XILINX, Intel (ex.ALTERA), Vicor, Microchip, Texas Instruments, Analog Devices, Mini-Circuits, Amphenol, Glenair.

Сотрудничество с глобальными дистрибьюторами электронных компонентов, предоставляет возможность заказывать и получать с международных складов практически любой перечень компонентов в оптимальные для Вас сроки.

На всех этапах разработки и производства наши партнеры могут получить квалифицированную поддержку опытных инженеров.

Система менеджмента качества компании отвечает требованиям в соответствии с ГОСТ Р ИСО 9001, ГОСТ РВ 0015-002 и ЭС РД 009

Офис по работе с юридическими лицами:

105318, г.Москва, ул.Щербаковская д.3, офис 1107, 1118, ДЦ «Щербаковский»

Телефон: +7 495 668-12-70 (многоканальный)

Факс: +7 495 668-12-70 (доб.304)

E-mail: info@moschip.ru

Skype отдела продаж:

moschip.ru

moschip.ru_4

moschip.ru_6

moschip.ru_9