



# LOW-VOLTAGE QUAD 2:1MUX/DEMUX BUS SWITCH

IDT74CBTLV3257

## FEATURES:

- Functionally equivalent to QS3257
- $5\Omega$  bi-directional switch connection between two ports
- Isolation under power-off conditions
- Over-voltage tolerant
- Latch-up performance exceeds 100mA
- $V_{CC} = 2.3V - 3.6V$ , Normal Range
- ESD > 2000V per MIL-STD-883, Method 3015;  
> 200V using machine model (C = 200pF, R = 0)
- Available in QSOP and TSSOP packages

## APPLICATIONS:

- 3.3V High Speed Bus Switching, Multiplexing, and Bus Isolation

## DESCRIPTION:

The CBTLV3257 is a quad 2:1 multiplexer/demultiplexer. The low on-state resistance of the switch allows connections to be made with minimal propagation delay.

The select (S) input controls the data flow. The multiplexers/demultiplexers are enabled when the output-enable ( $\overline{OE}$ ) input is low.

To ensure the high-impedance state during power up or power down,  $\overline{OE}$  should be tied to  $V_{CC}$  through a pullup resistor; the minimum value of the resistor is determined by the current-sinking capability of the driver.

## FUNCTIONAL BLOCK DIAGRAM

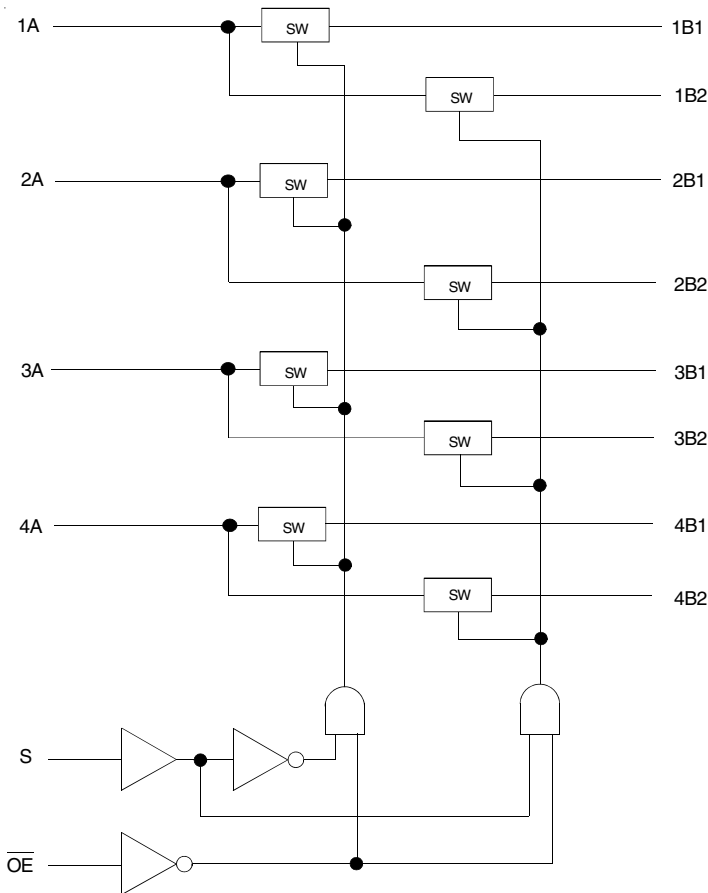

## SIMPLIFIED SCHEMATIC, EACH SWITCH

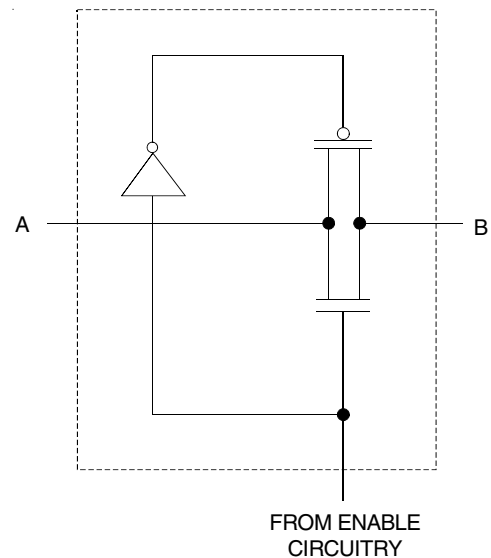

PIN CONFIGURATION

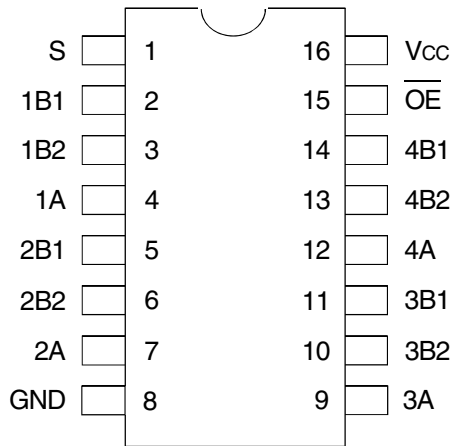

QSOP / TSSOP  
TOP VIEW

ABSOLUTE MAXIMUM RATINGS<sup>(1)</sup>

Symbol	Description	Max	Unit
V <sub>CC</sub>	Supply Voltage Range	-0.5 to +4.6	V
V <sub>I</sub>	Input Voltage Range	-0.5 to +4.6	V
	Continuous Channel Current	128	mA
I <sub>IK</sub>	Input Clamp Current, V <sub>I/O</sub> < 0	-50	mA
T <sub>STG</sub>	Storage Temperature	-65 to +150	°C

NOTE:

- Stresses greater than those listed under ABSOLUTE MAXIMUM RATINGS may cause permanent damage to the device. This is a stress rating only and functional operation of the device at these or any other conditions above those indicated in the operational sections of this specification is not implied. Exposure to absolute maximum rating conditions for extended periods may affect reliability.

FUNCTION TABLE<sup>(1)</sup>

Inputs		Function
$\overline{OE}$	S	
L	L	A Port = B1 Port
L	H	A Port = B2 Port
H	X	Disconnect

NOTE:

- H = HIGH Voltage Level  
L = LOW Voltage Level  
X = Don't Care

OPERATING CHARACTERISTICS, T<sub>A</sub> = 25°C<sup>(1)</sup>

Symbol	Parameter	Test Conditions	Min.	Max.	Unit
V <sub>CC</sub>	Supply Voltage		2.3	3.6	V
V <sub>IH</sub>	High-Level Control Input Voltage	V <sub>CC</sub> = 2.3V to 2.7V	1.7	—	V
		V <sub>CC</sub> = 2.7V to 3.6V	2	—	
V <sub>IL</sub>	Low-Level Control Input Voltage	V <sub>CC</sub> = 2.3V to 2.7V	—	0.7	V
		V <sub>CC</sub> = 2.7V to 3.6V	—	0.8	
T <sub>A</sub>	Operating Free-Air Temperature		-40	85	°C

NOTE:

- All unused control inputs of the device must be held at V<sub>CC</sub> or GND to ensure proper device operation.

## DC ELECTRICAL CHARACTERISTICS OVER OPERATING RANGE

Following Conditions Apply Unless Otherwise Specified:

Operating Conditions:  $T_A = -40^\circ\text{C}$  to  $+85^\circ\text{C}$

Symbol	Parameter	Test Conditions		Min.	Typ. <sup>(1)</sup>	Max.	Unit
$V_{IK}$	Control Inputs, Data Inputs	$V_{CC} = 3V, I_I = -18\text{mA}$		—	—	-1.2	V
$I_I$	Control Inputs	$V_{CC} = 3.6V, V_I = V_{CC}$ or GND		—	—	$\pm 1$	$\mu\text{A}$
$I_{OZ}$	Data I/O	$V_{CC} = 3.6V, V_O = 0$ or $3.6V$ , switch disabled		—	—	20	$\mu\text{A}$
$I_{OFF}$		$V_{CC} = 0, V_I$ or $V_O = 0$ to $3.6V$		—	—	50	$\mu\text{A}$
$I_{CC}$		$V_{CC} = 3.6V, I_O = 0, V_I = V_{CC}$ or GND		—	—	10	$\mu\text{A}$
$\Delta I_{CC}^{(2)}$	Control Inputs	$V_{CC} = 3.6V$ , one input at $3V$ , other inputs at $V_{CC}$ or GND		—	—	300	$\mu\text{A}$
$C_I$	Control Inputs	$V_I = 3V$ or $0$		—	4	—	pF
$C_{IO(OFF)}$	A Port	$V_O = 3V$ or $0, \overline{OE} = V_{CC} = 3.3V$		—	13	—	pF
	B Port			—	6	—	
$R_{ON}^{(3)}$	$V_{CC} = 2.3V$ Typ. at $V_{CC} = 2.5V$	$V_I = 0$	$I_O = 64\text{mA}$	—	5	8	$\Omega$
			$I_O = 24\text{mA}$	—	5	8	
		$V_I = 1.7V$	$I_O = 15\text{mA}$	—	27	40	
	$V_{CC} = 3V$	$V_I = 0$	$I_O = 64\text{mA}$	—	5	7	
			$I_O = 24\text{mA}$	—	5	7	
		$V_I = 2.4V$	$I_O = 15\text{mA}$	—	10	15	

NOTES:

- Typical values are at  $V_{CC} = 3.3V, +25^\circ\text{C}$  ambient.
- The increase in supply current is attributable to each current that is at the specified voltage level rather than  $V_{CC}$  or GND.
- This is measured by the voltage drop between the A and B terminals at the indicated current through the switch. On-state resistance is determined by the lower of the voltages of the two (A or B) terminals.

## SWITCHING CHARACTERISTICS

Symbol	Parameter	$V_{CC} = 2.5V \pm 0.2V$		$V_{CC} = 3.3V \pm 0.3V$		Unit
		Min.	Max.	Min.	Max.	
$t_{PD}^{(1)}$	Propagation Delay A to B or B to A	—	0.15	—	0.25	ns
$t_{SEL}$	Select Time S to A or B	1	6.1	1	5.3	ns
$t_{EN}$	Enable Time S to B	1	6.1	1	5.3	ns
$t_{DIS}$	Disable Time S to B	1	4.8	1	4.5	ns
$t_{EN}$	Output Enable Time $\overline{OE}$ to A or B	1	5.6	1	5	ns
$t_{DIS}$	Output Disable Time $\overline{OE}$ to A or B	1	5.5	1	5.5	ns

- NOTE:
- The propagation delay is the calculated RC time constant of the typical on-state resistance of the switch and the specified load capacitance driven by an ideal voltage source (zero output impedance).

## TEST CIRCUITS AND WAVEFORMS

### TEST CONDITIONS

Symbol	$V_{CC}^{(1)} = 3.3V \pm 0.3V$	$V_{CC}^{(2)} = 2.5V \pm 0.2V$	Unit
$V_{LOAD}$	6	$2 \times V_{CC}$	V
$V_{IH}$	3	$V_{CC}$	V
$V_T$	1.5	$V_{CC} / 2$	V
$V_{LZ}$	300	150	mV
$V_{HZ}$	300	150	mV
$C_L$	50	30	pF

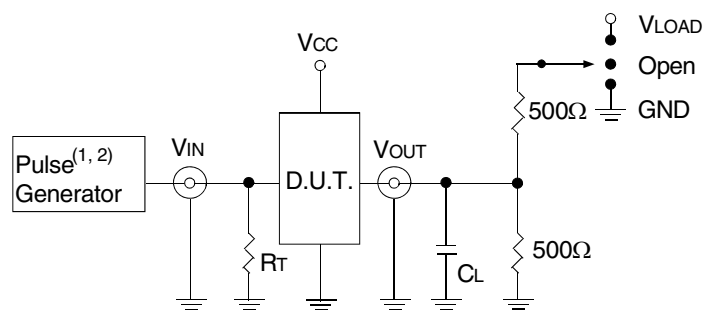

Test Circuits for All Outputs

#### DEFINITIONS:

$C_L$  = Load capacitance: includes jig and probe capacitance.  
 $R_T$  = Termination resistance: should be equal to  $Z_{OUT}$  of the Pulse Generator.

#### NOTES:

1. Pulse Generator for All Pulses: Rate  $\leq 10\text{MHz}$ ;  $t_r \leq 2.5\text{ns}$ ;  $t_f \leq 2.5\text{ns}$ .
2. Pulse Generator for All Pulses: Rate  $\leq 10\text{MHz}$ ;  $t_r \leq 2\text{ns}$ ;  $t_f \leq 2.5\text{ns}$ .

### SWITCH POSITION

Test	Switch
$t_{PLZ}/t_{PZL}$	$V_{LOAD}$
$t_{PHZ}/t_{PZH}$	GND
$t_{SEL}$	Open
$t_{PD}$	Open

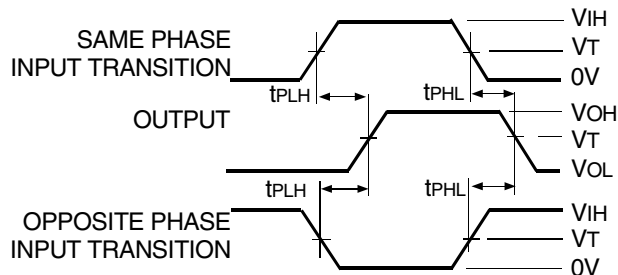

Propagation Delay

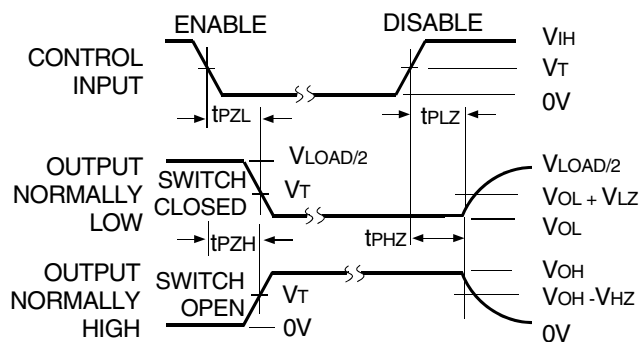

Enable and Disable Times

## ORDERING INFORMATION

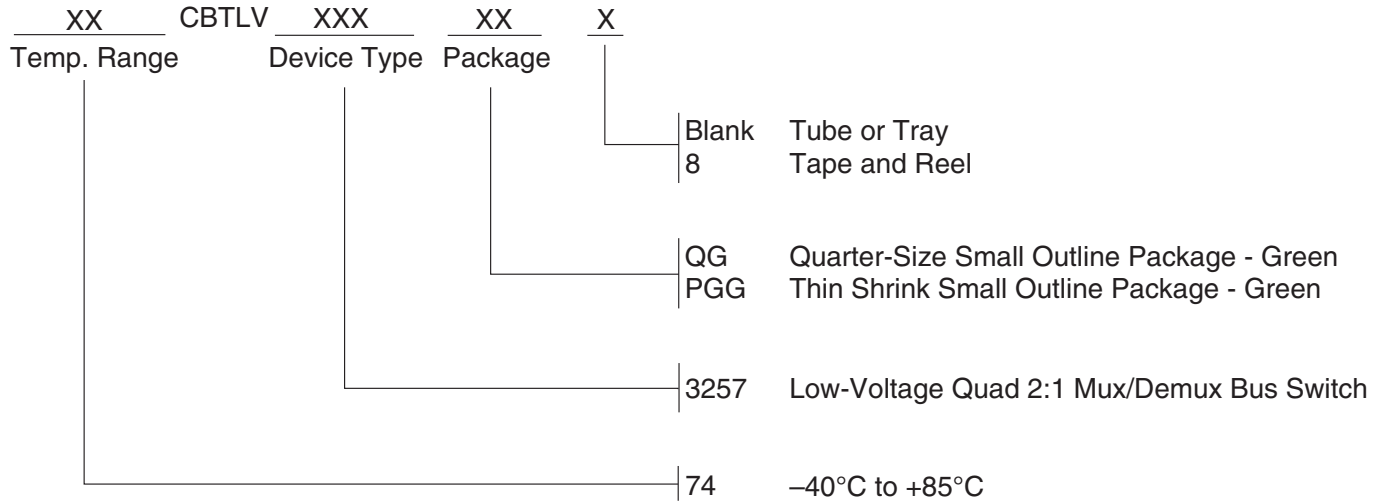

## Datasheet Document History

12/18/2014 Pg. 5 Updated the ordering information by removing non RoHS part and by adding Tape and Reel information.



**CORPORATE HEADQUARTERS**  
6024 Silver Creek Valley Road  
San Jose, CA 95138

**for SALES:**  
800-345-7015 or 408-284-8200  
fax: 408-284-2775  
www.idt.com

**for Tech Support:**  
logichelp@idt.com

## Данный компонент на территории Российской Федерации

### Вы можете приобрести в компании MosChip.

Для оперативного оформления запроса Вам необходимо перейти по данной ссылке:

<http://moschip.ru/get-element>

Вы можете разместить у нас заказ для любого Вашего проекта, будь то серийное производство или разработка единичного прибора.

В нашем ассортименте представлены ведущие мировые производители активных и пассивных электронных компонентов.

Нашей специализацией является поставка электронной компонентной базы двойного назначения, продукции таких производителей как XILINX, Intel (ex.ALTERA), Vicor, Microchip, Texas Instruments, Analog Devices, Mini-Circuits, Amphenol, Glenair.

Сотрудничество с глобальными дистрибьюторами электронных компонентов, предоставляет возможность заказывать и получать с международных складов практически любой перечень компонентов в оптимальные для Вас сроки.

На всех этапах разработки и производства наши партнеры могут получить квалифицированную поддержку опытных инженеров.

Система менеджмента качества компании отвечает требованиям в соответствии с ГОСТ Р ИСО 9001, ГОСТ РВ 0015-002 и ЭС РД 009

### Офис по работе с юридическими лицами:

105318, г.Москва, ул.Щербаковская д.3, офис 1107, 1118, ДЦ «Щербаковский»

Телефон: +7 495 668-12-70 (многоканальный)

Факс: +7 495 668-12-70 (доб.304)

E-mail: [info@moschip.ru](mailto:info@moschip.ru)

Skype отдела продаж:

moschip.ru

moschip.ru\_4

moschip.ru\_6

moschip.ru\_9