

Product Overview

The QPQ1287 is a high performance Bulk Acoustic Wave (BAW) filter designed to meet the strict LTE rejection requirements for use in B40, Full Band 2300-2400 MHz. The QPQ1287 is specifically designed to meet the high performance expectations of insertion loss and rejection for LTE TDD systems under all operating conditions.

The QPQ1287 is manufactured using Qorvo's world class BAW technology and is housed in a compact, industry standard 2.0 mm x 1.6 mm x 0.73 mm package that is lead free and RoHS compliant.

The QPQ1287 is part of Qorvo's extensive portfolio of RF BAW and SAW filters.

Functional Block Diagram

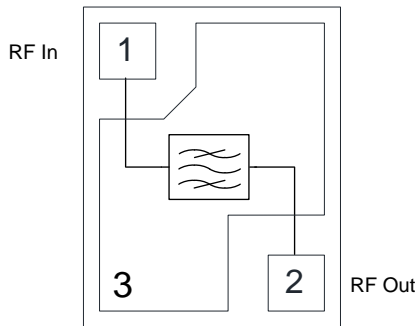

Pin Configuration - Single Ended

Pin No.	Label
1	RF Input
2	RF Output
3	Ground



3 Pad 2.0 mm x 1.6 mm x 0.73 mm SMT Package

Key Features

- Highly Selective BAW Filter
- Low Insertion Loss Over Full Bandwidth and Operating Conditions
- Performance over -20 to +90 °C
- Excellent Wi-Fi Rejection
- Single-Ended Operation
- Internally Matched to 50 Ohms
- High Power Handling for Small Cells
- Small Size: 2.00 x 1.60 x 0.73 mm
- **RoHS** compliant (2002/95/EC), **Pb-free**

Applications

- Band 40 TD-LTE
- 2300 – 2400 MHz Band
- Small Cells Base Stations

Ordering Information

Part No.	Description
QPQ1287SB	Sample Bag with 5 pieces
QPQ1287SR	Sample Reel with 100 pieces
QPQ1287TR7	7" Taped Reel with 2500 pieces
QPQ1287EVB	Assembled Evaluation Board

Absolute Maximum Ratings ⁽¹⁾

Parameter	Rating
Storage Temperature	-40 to +125 °C
Operating Temperature ⁽²⁾	-40 to +105 °C

Notes:

1. Operation of this device outside the parameter ranges given may cause permanent damage.
2. Device will function but it is not guaranteed to meet electrical specifications

Electrical Specifications ⁽¹⁾

Test conditions unless otherwise specified. Temperature Range: -20 to +90 °C

Parameter	Conditions ^(1, 2)	Min	Typ ⁽⁶⁾	Max	Unit
Average Insertion Loss ⁽²⁾	2300 – 2310 MHz	-	3.1	3.9	dB
	2310 – 2380 MHz	-	2.2	3.0	
	2380 – 2390 MHz	-	2.2	3.2	
	2390 – 2400 MHz	-	2.7	3.9	
Input / Output VSWR	2300.0 – 2400.0 MHz	-	2.0:1	2.25:1	-
Input / Output Return Loss	2300.0 – 2400.0 MHz	8.3	9.3	-	dB
Amplitude Variation ⁽³⁾ (over any 10 MHz window)	2300.0 – 2400.0 MHz	-	1.2	2.5	dB
	2305.0 – 2395.0 MHz	-	0.8	1.5	
Group Delay Variation ⁽⁴⁾ (over any 10 MHz window)	2300.0 – 2400.0 MHz	-	9.1	25	ns p-p
Phase Ripple ⁽⁴⁾ (over any 10 MHz window)	2300.0 – 2400.0 MHz	-	4.2	20	Deg. p-p
Attenuation in WIFI Band ⁽⁵⁾ (Average per Channel using 802.11b Spectrum mask)	2401 – 2423 MHz (Channel 1)	5	16	-	dB
	2406 – 2428 MHz (Channel 2)	10	28	-	
	2411 – 2433 MHz (Channel 3)	20	40	-	
	2416 – 2463 MHz (Channel 4–9)	45	54	-	
	2446 – 2468 MHz (Channel 10)	45	51	-	
	2451 – 2473 MHz (Channel 11)	45	49	-	
	2456 – 2478 MHz (Channel 12)	43	48	-	
	2461 – 2483 MHz (Channel 13)	43	47	-	
2473 – 2495 MHz (Channel 14)	40	45	-		
Attenuation ⁽⁷⁾	10 – 766 MHz	50	54	-	dB
	869 – 894 MHz	47	50	-	
	1150 – 1195 MHz	40	44	-	
	1574.4 – 1576.4 MHz	35	38	-	
	1710 – 2170 MHz	34	36	-	
	2500 – 2690 MHz	35	38	-	
	3400 – 3500 MHz	30	36	-	
	4600 – 4800 MHz	27	33	-	
5150 – 5850 MHz	23	27	-		
6000 – 8000 MHz	25	30	-		
2 nd Harmonic ⁽⁸⁾	Pin = +29 dBm (2300–2400 MHz)	55	65	-	dBc
Source/Load Impedance ⁽⁹⁾	Single-ended	-	50	-	Ω

Notes:

1. All specifications are based on the QORVO schematic for the main reference design shown on page 5.
2. Average Insertion Loss is calculated by averaging |S₂₁| in dB for each measured point within defined frequency range .
3. Amplitude Variation is defined as the difference between the lowest loss and the highest loss within 10 MHz channels.
4. This is defined as the worst difference between a peak and adjacent valley within defined frequency points.
5. WIFI attenuation is calculated by averaging |S₂₁| in dB referenced to ZERO dB for each measured point within defined frequency range.
6. Typical values are an average of 20 pieces measured at a temperature of +25 °C.
7. Attenuation is referenced to zero dB
8. Non-Linear Response is not the same for Pin 2 input.
9. This is the optimum impedance in order to achieve the performance shown.

Life Test

Conditions	Rating
P _{IN} =+29 dBm, Temp.=+90 °C, FD-LTE, 5 MHz, 16QAM, PAR=8 dB	>87600 hrs.

Evaluation Board and Schematic – QPQ1287EVB

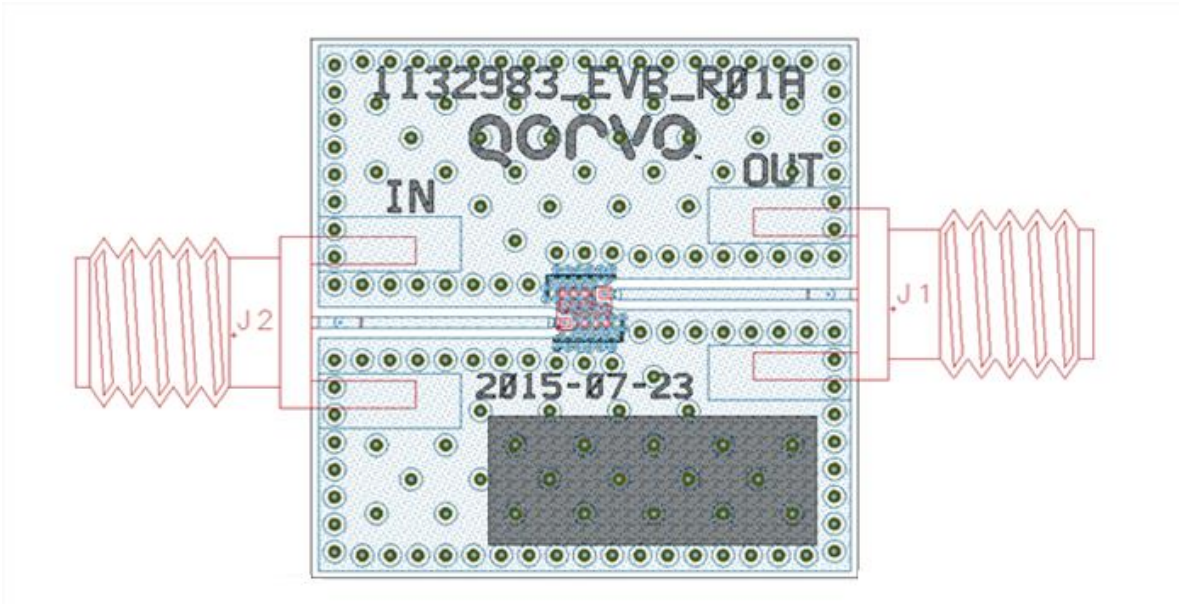

- Notes:
1. Top, middle & bottom layers: 1/2 oz copper, Substrates: FR4 dielectric, .062" thick, Finish plating: Nickel: 3-8 μ m thick, Gold: .03-.2 μ m thick, Hole plating: Copper min .0008 μ m thick.

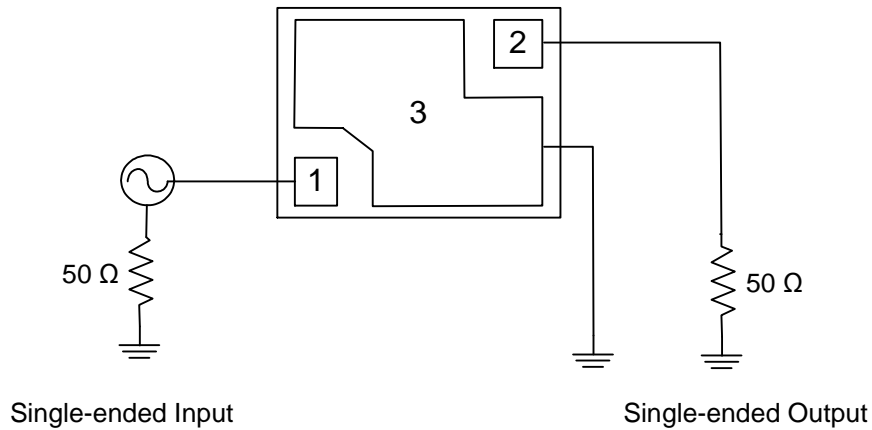

Bill of Material – QPQ1287EVB

Ref. Des.	Value	Description	Manufacturer	Part Number
U1	N/A	2350.0 MHz BAW Filter	Qorvo	QPQ1287
N/A	N/A	Printed Circuit Board	Qorvo	1132983
N/A	N/A	SMA Edge Connector	Radial	9602-1111-018

Performance Plots – QPQ1287EVB

Test conditions unless otherwise noted: Temp.= +25 °C

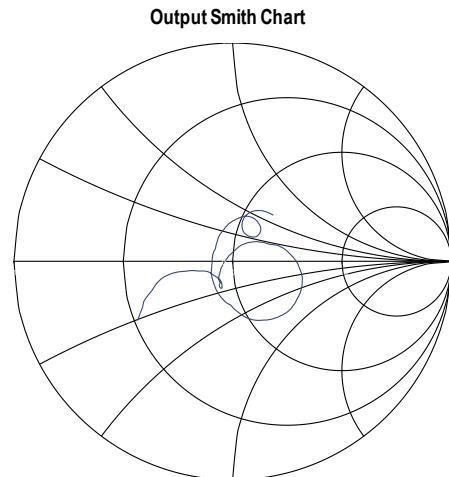
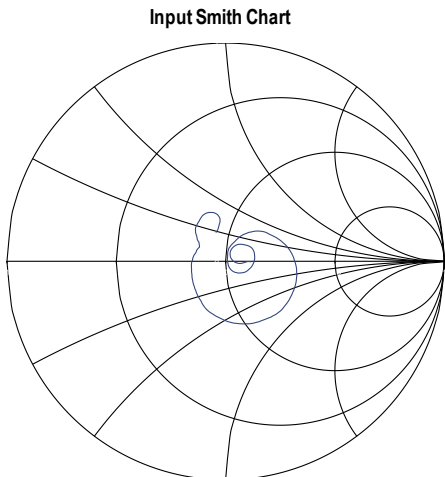
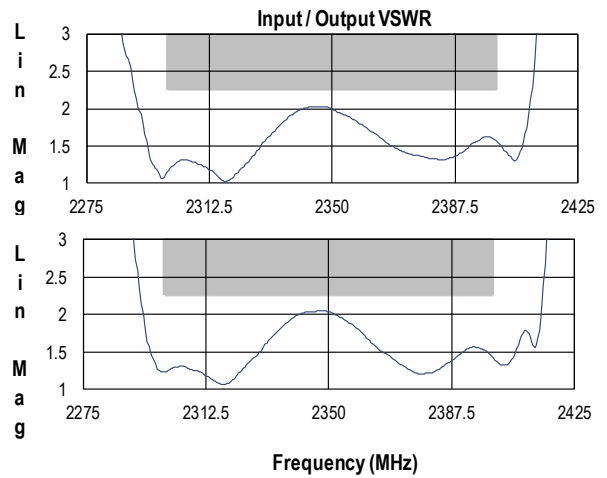
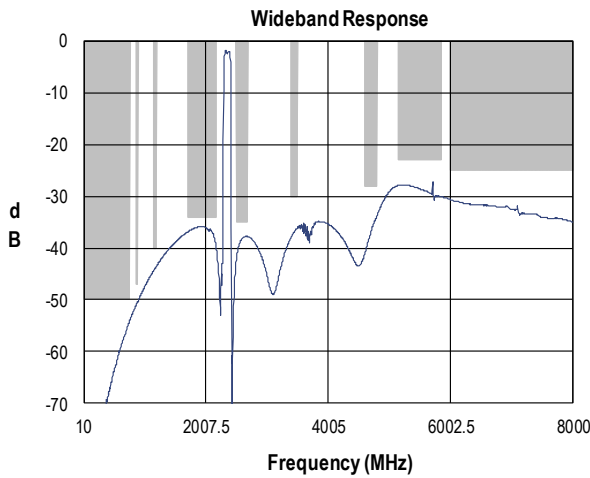
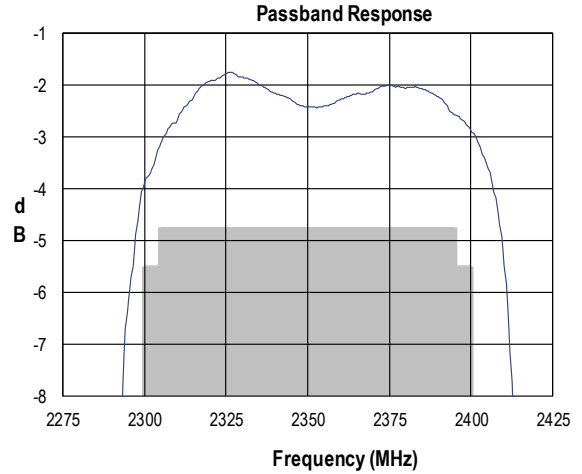
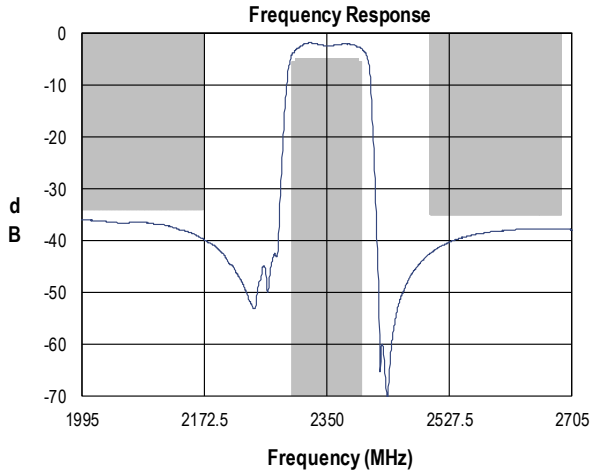

Package Marking and Dimensions

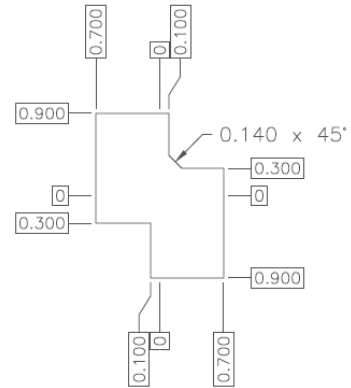
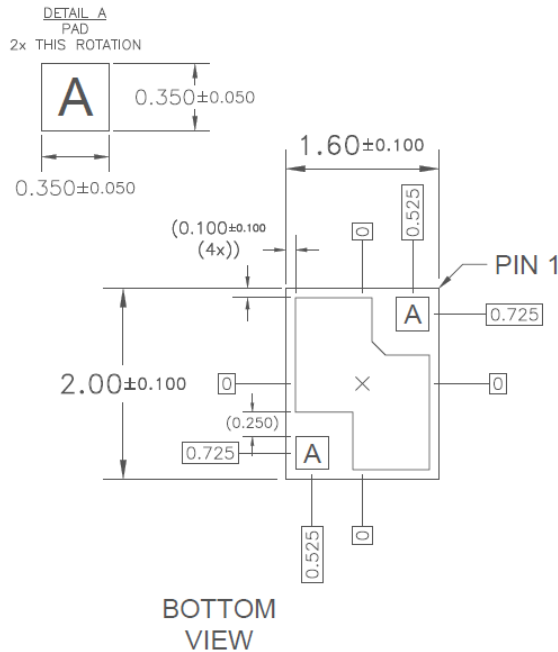
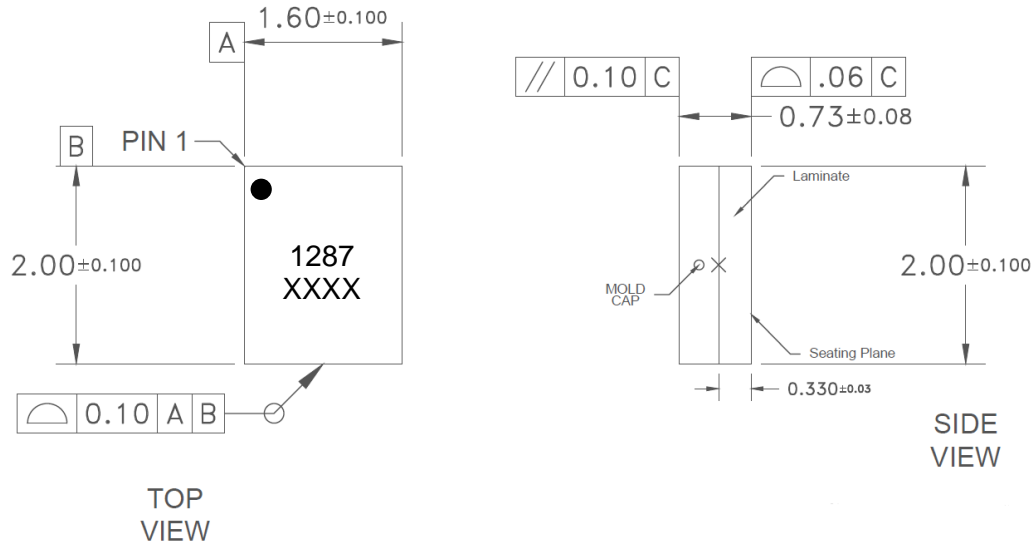

Notes:

1. All dimensions are in millimeters. Angles are in degrees.
2. Dimension and tolerance formats conform to ASME Y14.4M-1994.
3. The terminal #1 identifier and terminal numbering conform to JESD 95-1 SPP-012.
4. Body: Al_2O_3 ceramic
5. Lid: Kovar, Au over Ni plating
6. Terminations: Au plating 0.5 - 1.0 μ m, over a 2-6 μ m Ni plating
7. An asterisk (*) in front of the marking code indicates prototype.

PCB Mounting Pattern

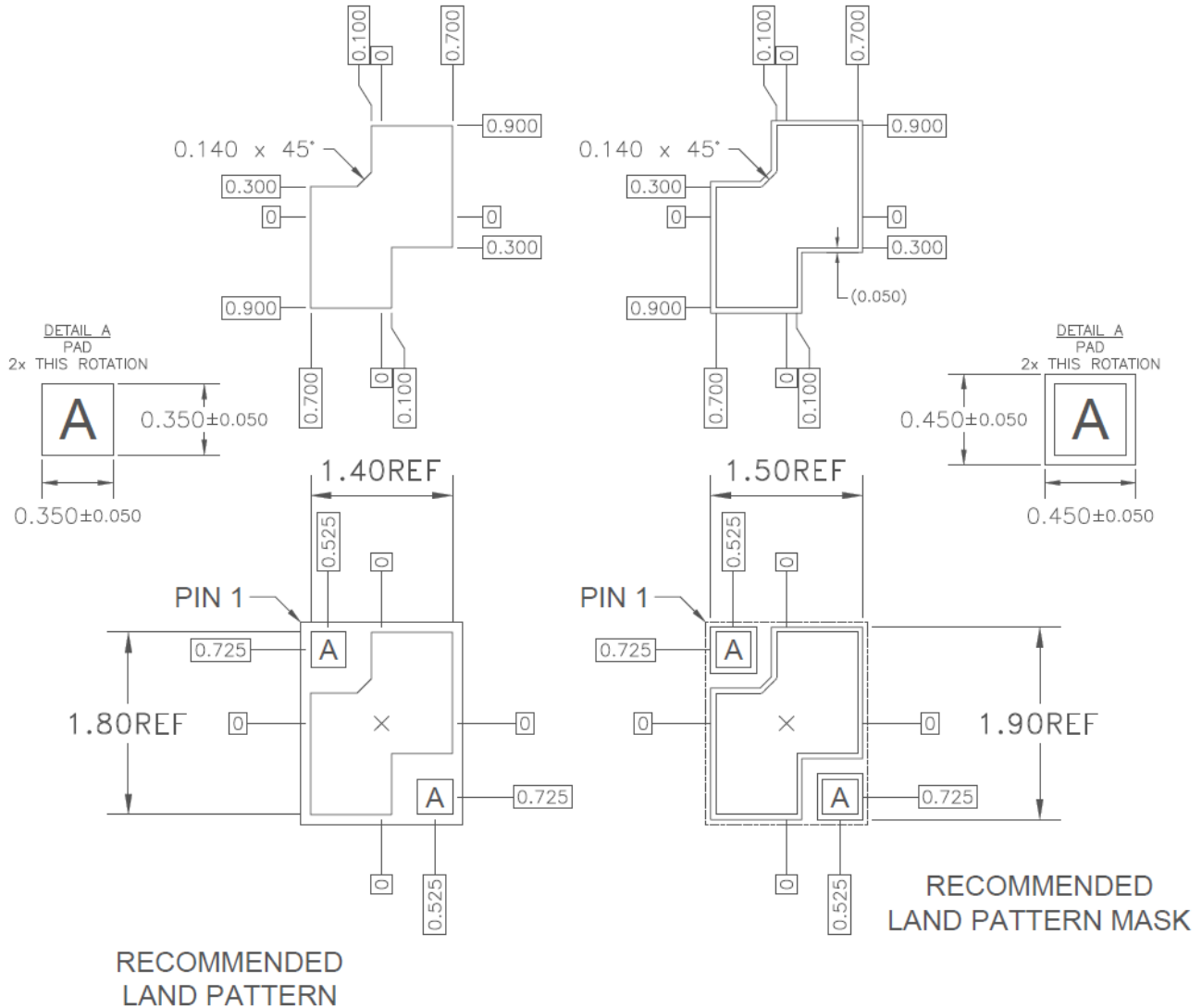

Notes:

1. All dimensions are in millimeters. Angles are in degrees.
2. Use 1 oz. copper minimum for top and bottom layer metal.

Tape and Reel Information – Carrier and Cover Tape Dimensions

Tape and reel specifications for this part are also available on the Qorvo website.
 Standard T/R size = 2500 pieces on a 7” reel.

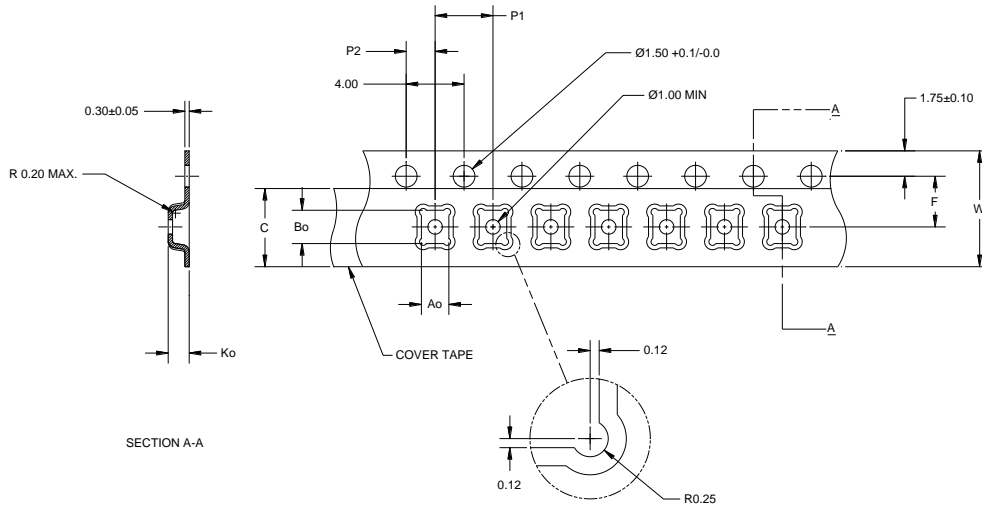

Feature	Measure	Symbol	Size (in)	Size (mm)
Cavity	Length	A0	0.077	1.95
	Width	B0	0.093	2.35
	Depth	K0	0.045	1.15
	Pitch	P1	0.157	4.00
Centerline Distance	Cavity to Perforation - Length Direction	P2	0.079	2.00
	Cavity to Perforation - Width Direction	F	0.138	3.50
Cover Tape	Width	C	0.213	5.40
Carrier Tape	Width	W	0.315	8.00

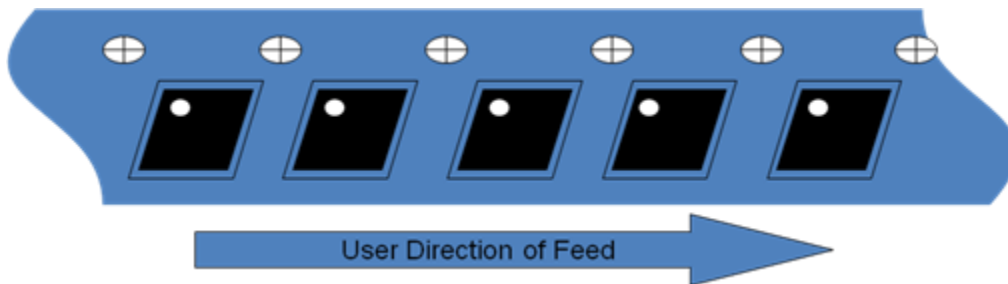

Tape and Reel Information – Reel Dimensions

Tape and reel specifications for this part are also available on the Qorvo website.
 Standard T/R size = 2500 pieces on a 7" reel.

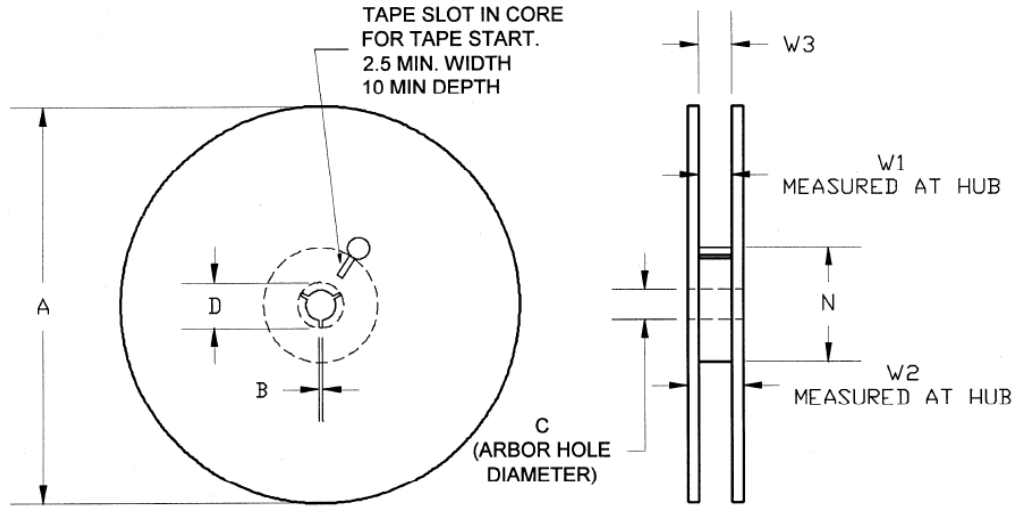

Feature	Measure	Symbol	Size (in)	Size (mm)
Flange	Diameter	A	6.969	177.0
	Thickness	W2	0.559	14.2
	Space Between Flange	W1	0.346	8.8
Hub	Outer Diameter	N	2.283	58.0
	Arbor Hole Diameter	C	0.512	13.0
	Key Slit Width	B	0.079	2.0
	Key Slit Diameter	D	0.787	20.0

Handling Precautions

Parameter	Rating	Standard
ESD – Human Body Model (HBM)	Class 3B	ESDA / JEDEC JS-001-2012
ESD – Charged Device Model (CDM)	Class C3	ESDA / JEDEC JS-002-2014
MSL – Moisture Sensitivity Level	Level 3	IPC/JEDEC J-STD-020



Caution!
 ESD-Sensitive Device

Solderability

Compatible with both lead-free (260°C max. reflow temp.) and tin/lead (245°C max. reflow temp.) soldering processes. Solder profiles available upon request.

Contact Plating: Au plating 0.5 - 1.0µm, over a 2-6µm Ni plating

RoHS Compliance

This part is compliant with 2011/65/EU RoHS directive (Restrictions on the Use of Certain Hazardous Substances in Electrical and Electronic Equipment) as amended by Directive 2015/863/EU.

This product also has the following attributes:

- Lead Free
- Halogen Free (Chlorine, Bromine)
- Antimony Free
- TBBP-A (C₁₅H₁₂Br₄O₂) Free
- PFOS Free
- SVHC Free



Contact Information

For the latest specifications, additional product information, worldwide sales and distribution locations:

Web: www.qorvo.com

Tel: 1-844-890-8163

Email: customer.support@qorvo.com

For technical questions and application information: **Email:** appsupport@qorvo.com

Important Notice

The information contained herein is believed to be reliable; however, Qorvo makes no warranties regarding the information contained herein and assumes no responsibility or liability whatsoever for the use of the information contained herein. All information contained herein is subject to change without notice. Customers should obtain and verify the latest relevant information before placing orders for Qorvo products. The information contained herein or any use of such information does not grant, explicitly or implicitly, to any party any patent rights, licenses, or any other intellectual property rights, whether with regard to such information itself or anything described by such information. **THIS INFORMATION DOES NOT CONSTITUTE A WARRANTY WITH RESPECT TO THE PRODUCTS DESCRIBED HEREIN, AND QORVO HEREBY DISCLAIMS ANY AND ALL WARRANTIES WITH RESPECT TO SUCH PRODUCTS WHETHER EXPRESS OR IMPLIED BY LAW, COURSE OF DEALING, COURSE OF PERFORMANCE, USAGE OF TRADE OR OTHERWISE, INCLUDING THE IMPLIED WARRANTIES OF MERCHANTABILITY AND FITNESS FOR A PARTICULAR PURPOSE.**

Without limiting the generality of the foregoing, Qorvo products are not warranted or authorized for use as critical components in medical, life-saving, or life-sustaining applications, or other applications where a failure would reasonably be expected to cause severe personal injury or death.

Copyright 2017 © Qorvo, Inc. | Qorvo is a registered trademark of Qorvo, Inc.

Данный компонент на территории Российской Федерации

Вы можете приобрести в компании MosChip.

Для оперативного оформления запроса Вам необходимо перейти по данной ссылке:

<http://moschip.ru/get-element>

Вы можете разместить у нас заказ для любого Вашего проекта, будь то серийное производство или разработка единичного прибора.

В нашем ассортименте представлены ведущие мировые производители активных и пассивных электронных компонентов.

Нашей специализацией является поставка электронной компонентной базы двойного назначения, продукции таких производителей как XILINX, Intel (ex.ALTERA), Vicor, Microchip, Texas Instruments, Analog Devices, Mini-Circuits, Amphenol, Glenair.

Сотрудничество с глобальными дистрибьюторами электронных компонентов, предоставляет возможность заказывать и получать с международных складов практически любой перечень компонентов в оптимальные для Вас сроки.

На всех этапах разработки и производства наши партнеры могут получить квалифицированную поддержку опытных инженеров.

Система менеджмента качества компании отвечает требованиям в соответствии с ГОСТ Р ИСО 9001, ГОСТ РВ 0015-002 и ЭС РД 009

Офис по работе с юридическими лицами:

105318, г.Москва, ул.Щербаковская д.3, офис 1107, 1118, ДЦ «Щербаковский»

Телефон: +7 495 668-12-70 (многоканальный)

Факс: +7 495 668-12-70 (доб.304)

E-mail: info@moschip.ru

Skype отдела продаж:

moschip.ru

moschip.ru_4

moschip.ru_6

moschip.ru_9