

features

- Monolithic structure provides high reliability in a wide temperature and humidity range
- High quality ceramic material and unique manufacturing process provides high Q at high frequency
- Nickel barrier with solder overcoat for excellent solderability
- Marking: Brown body color with no marking (1E)
White body color with with black stripe and no marking (1J)
- Products with lead-free terminations meet EU RoHS requirements

dimensions and construction

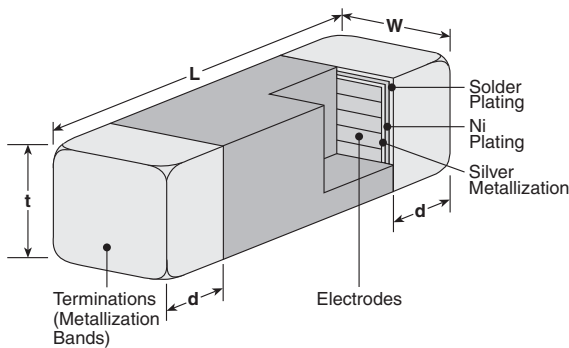

Size Code	Dimensions inches (mm)			
	L	W	t	d
1E (0402)	.039±.004 (1.0±0.1)	.02±.004 (0.5±0.1)	.02±.004 (0.5±0.1)	.01±.004 (0.25±0.1)
1J (0603)	.063±.006 (1.6±0.15)	.031±.006 (0.8±0.15)	.031±.006 (0.8±0.15)	.014±.006 (0.36±0.15)

ordering information

New Part #	MHL	1E	C	T	TE	3N9	S
	Type	Size Code	Material	Termination Material	Packaging	Nominal Inductance	Tolerance
		1E 1J	Permeability Code: C T	T: Sn	TP: 7" paper tape 2 mm pitch (1E only - 10,000 pieces/reel) TD: 7" paper tape (1J - 4,000 pieces/reel)	3N9 = 3.9nH R10 = 100nH	S: ±0.3nH J: ±5%

For further information on packaging, please refer to Appendix A.

applications and ratings

Part Designation	Inductance L (nH)	Inductance Tolerance	Q			Self Resonant Frequency Typical (MHz)	DC Resistance Maximum (Ω)	Allowable DC Current Maximum (mA)	Operating Temperature Range
			Minimum (100MHz)	Typical (100MHz)	Typical (800MHz)				
MHL1ECTTP1N0*	1.0	S: ±0.3nH	8	11	42	10000	0.12	300	-55°C to +125°C
MHL1ECTTP1N2*	1.2				40	8000	0.13		
MHL1ECTTP1N5*	1.5				35	6000	0.14		
MHL1ECTTP1N8*	1.8						0.16		
MHL1ECTTP2N2*	2.2						0.17		
MHL1ECTTP2N7*	2.7				32	4000	0.19		
MHL1ECTTP3N3*	3.3						0.22		
MHL1ECTTP3N9*	3.9						0.24		
MHL1ECTTP4N7*	4.7						0.27		
MHL1ECTTP5N6*	5.6								

Specifications given herein may be changed at any time without prior notice. Please confirm technical specifications before you order and/or use.

1/13/11

applications and ratings (continued)

Part Designation	Inductance L (nH)	Inductance Tolerance	Q			Self Resonant Frequency Typical (MHz)	DC Resistance Maximum (Ω)	Allowable DC Current Maximum (mA)	Operating Temperature Range				
			Minimum (100MHz)	Typical (100MHz)	Typical (800MHz)								
MHL1ECTTP6N8*	6.8	J: ±5%	8	11	32	3900	0.32	300	-55°C to +125°C				
MHL1ECTTP8N2*	8.2					3500	0.37						
MHL1ECTTP10N*	10					31	3200			0.42			
MHL1ECTTP12N*	12						2600			0.50			
MHL1ECTTP15N*	15					30	2300			0.55			
MHL1ECTTP18N*	18						2000			0.65			
MHL1ECTTP22N*	22					1600	0.8	200					
MHL1ECTTP27N*	27					28	1400			0.9			
MHL1ECTTP33N*	33					26	1200			1.0			
MHL1ECTTP39N*	39					24	1100			1.2			
MHL1ECTTP47N*	47					23	900			1.3			
MHL1ECTTP56N*	56					21	750			1.4	180		
MHL1ECTTP68N*	68					19							
MHL1ECTTP82N*	82					10	16	600		1.6	150		
MHL1ECTTPR10*	100						—				100		
NEW MHL1ECTTPR12*	120						—						
MHL1JCTTD1N5*	1.5					S: ±0.3nH	8	14		6000	0.10	1000	-55°C to +125°C
MHL1JCTTD1N8*	1.8												
MHL1JCTTD2N2*	2.2												
MHL1JCTTD2N7*	2.7												
MHL1JCTTD3N3*	3.3												
MHL1JCTTD3N9*	3.9												
MHL1JCTTD4N7*	4.7												
MHL1JCTTD5N6*	5.6	10	46	4000	0.20								
MHL1JCTTD6N8*	6.8				0.23								
MHL1JCTTD8N2*	8.2	J: ±5%	12	15	0.25	600							
MHL1JCTTD10N*	10				0.28								
MHL1JCTTD12N*	12				0.30								
MHL1JCTTD15N*	15				0.35								
MHL1JCTTD18N*	18				0.40								
MHL1JCTTD22N*	22				0.45								
MHL1JCTTD27N*	27				18	1600	0.50						
MHL1JCTTD33N*	33					1400	0.55						
MHL1JCTTD39N*	39				17	1200	0.60	500					
MHL1JCTTD47N*	47					1100	0.65						
MHL1JCTTD56N*	56	15	15	39	0.70	400							
MHL1JCTTD68N*	68			37	0.75								
MHL1JCTTD82N*	82			36	0.80								
MHL1JCTTD82N*	82			29	0.85								
MHL1JCTTDR10*	100	8	13	16	600	0.90	300						
MHL1JCTTDR12*	120				500	1.0							
MHL1JCTTDR15*	150				500	1.2							
MHL1JCTTDR18*	180				—	1.3							
MHL1JCTTDR22*	220				400	1.5							

*Add tolerance character (S, J)

For complete environmental specifications, please refer to www.koaspeer.com

Данный компонент на территории Российской Федерации

Вы можете приобрести в компании MosChip.

Для оперативного оформления запроса Вам необходимо перейти по данной ссылке:

<http://moschip.ru/get-element>

Вы можете разместить у нас заказ для любого Вашего проекта, будь то серийное производство или разработка единичного прибора.

В нашем ассортименте представлены ведущие мировые производители активных и пассивных электронных компонентов.

Нашей специализацией является поставка электронной компонентной базы двойного назначения, продукции таких производителей как XILINX, Intel (ex.ALTERA), Vicor, Microchip, Texas Instruments, Analog Devices, Mini-Circuits, Amphenol, Glenair.

Сотрудничество с глобальными дистрибьюторами электронных компонентов, предоставляет возможность заказывать и получать с международных складов практически любой перечень компонентов в оптимальные для Вас сроки.

На всех этапах разработки и производства наши партнеры могут получить квалифицированную поддержку опытных инженеров.

Система менеджмента качества компании отвечает требованиям в соответствии с ГОСТ Р ИСО 9001, ГОСТ РВ 0015-002 и ЭС РД 009

Офис по работе с юридическими лицами:

105318, г.Москва, ул.Щербаковская д.3, офис 1107, 1118, ДЦ «Щербаковский»

Телефон: +7 495 668-12-70 (многоканальный)

Факс: +7 495 668-12-70 (доб.304)

E-mail: info@moschip.ru

Skype отдела продаж:

moschip.ru

moschip.ru_4

moschip.ru_6

moschip.ru_9