

### FEATURES

- Powered from 3.15 V to 26 V
- Precision current sense amplifier
- Precision voltage input
- 12-bit ADC for current and voltage readback
- ALERT output allows basic P-channel FET hot swap up to 26 V
- SETV input for setting overcurrent alert threshold
- Programmable overcurrent filtering via TIMER pin
- CLRB input pin
- I<sup>2</sup>C fast mode-compliant interface (400 kHz maximum)
- 10-lead MSOP

### APPLICATIONS

- Power monitoring/power budgeting
- Central office equipment
- Telecommunications and data communications equipment
- PCs/servers

### GENERAL DESCRIPTION

The [ADM1192](#) is an integrated current sense amplifier that offers digital current and voltage monitoring via an on-chip 12-bit analog-to-digital converter (ADC), communicated through an I<sup>2</sup>C<sup>®</sup> interface.

An internal current sense amplifier measures voltage across the sense resistor in the power path via the VCC pin and the SENSE pin.

A 12-bit ADC can measure the current seen in the sense resistor and in the supply voltage on the VCC pin. An industry-standard I<sup>2</sup>C interface allows a controller to read current and voltage data from the ADC. Measurements can be initiated by an I<sup>2</sup>C command. Alternatively, the ADC can run continuously, and the user can read the latest conversion data whenever it is required. Up to four unique I<sup>2</sup>C addresses can be created, depending on the way the ADR pin is connected.

A SETV pin is also included. A voltage applied to this pin is internally compared with the output voltage on the current sense amplifier. The output of the SETV comparator asserts when the current sense amplifier output exceeds the SETV voltage. This event is detected at the ALERT block. The ALERT block then charges up the external TIMER capacitor with a fixed current. When this timing cycle is complete, the ALERT output asserts.

### FUNCTIONAL BLOCK DIAGRAM

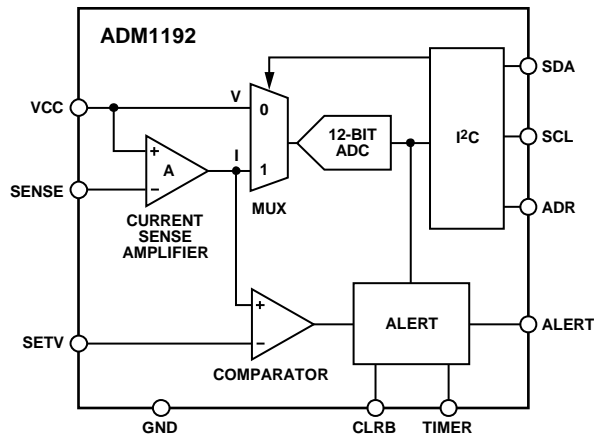

Figure 1.

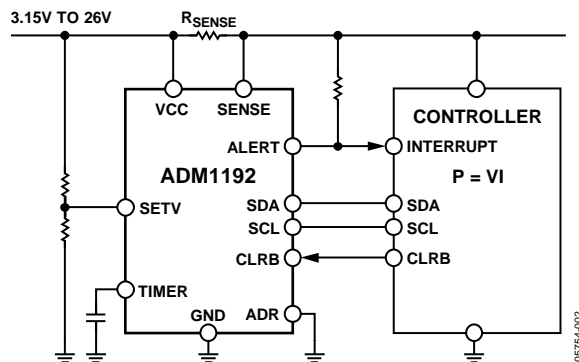

Figure 2. Applications Diagram

The ALERT output can be used as a flag to warn a microcontroller or field programmable gate array (FPGA) of an overcurrent condition. ALERT outputs of multiple [ADM1192](#) devices can be tied together and used as a combined alert.

A basic P-channel FET hot swap circuit can be implemented with the ALERT output. The value of the TIMER capacitor should be set so that the charging time of this capacitor is much longer than the period during which a higher than nominal inrush current may be flowing.

The [ADM1192](#) is packaged in a 10-lead MSOP.

## TABLE OF CONTENTS

Features .....	1
Applications .....	1
General Description .....	1
Functional Block Diagram .....	1
Revision History .....	2
Specifications .....	3
Absolute Maximum Ratings .....	5
Thermal Characteristics .....	5
ESD Caution .....	5
Pin Configuration and Function Descriptions .....	6
Typical Performance Characteristics .....	7
Voltage and Current Readback .....	10
Serial Bus Interface .....	10

## REVISION HISTORY

### 7/13—Rev. C to Rev. D

Changed SETV Pin Rating, Table 2 .....	5
Changes to CLR_B Pin and ALERT Pin Descriptions, Table 4 ...	6
Changes to Table 15 .....	15
Changes to the Implementing a Basic Hot Swap Circuit and the SETV Pin Sections .....	16
Changes to Figure 28 .....	16
Moved the Kelvin Sense Resistor Connection Section .....	16

### 6/12—Rev. B to Rev. C

Changes to Low Level Input Voltage, $V_{IL}$ Parameter, Test Conditions/Comments Column, Table 1 and High Level Input Voltage, $V_{IH}$ Parameter, Test Conditions/Comments Column, Table 1 .....	3
Changes to SETV Pin Parameter, Rating Column, Table 2 .....	5
Changes to Pin 3, Description Column, Table 4 and Pin 10 Description Column, Table 4 .....	6
Changes to Bit 2, Function Column, Table 9 .....	13
Changes to Overcurrent Flag Section .....	16
Changes to Kelvin Sense Resistor Connection Section .....	17
Deleted Figure 30; Renumbered Sequentially .....	17
Updated Outline Dimensions .....	18

### 2/08—Rev. A to Rev. B

Changes to Figure 2 .....	1
Changed $V_{VCC}$ to $V_{CC}$ Throughout .....	3

Identifying the ADM1192 on the I <sup>2</sup> C Bus .....	10
General I <sup>2</sup> C Timing .....	10
Write and Read Operations .....	12
Quick Command .....	12
Write Command Byte .....	12
Write Extended Command Byte .....	13
Read Voltage and/or Current Data Bytes .....	14
Applications Information .....	16
ALERT Output .....	16
SETV Pin .....	16
Kelvin Sense Resistor Connection .....	16
Outline Dimensions .....	17
Ordering Guide .....	17

Added ADC Conversion Time Parameter .....	3
Changes to Input Current for 00 Decode, $I_{ADRLOW}$ , Parameter ...	4
Changes to Input Current for 11 Decode, $I_{ADRHIGH}$ , Parameter ...	4
Added Endnote 2 .....	4
Changes to Figure 6 .....	7
Changes to Figure 17 .....	9
Changes to General I <sup>2</sup> C Timing Section, Step 3 .....	10
Changes to Table 5 .....	10
Changes to Quick Command Section .....	12
Changes to Figure 21 .....	12
Changes to Table 7 .....	12
Changes to Write Extended Command Byte Section .....	13
Changes to Figure 23 .....	13
Changes to Table 9 and Table 11 .....	13
Changes to Converting ADC Codes to Voltage and Current Readings Section .....	14
Changes to Figure 27 .....	16

### 4/07—Rev. 0 to Rev. A

Changes to Table 5 .....	10
Changes to Figure 18 and Figure 19 .....	11
Changes to Figure 23 .....	13
Changes to Figure 25 and Figure 26 .....	14
Added Applications Information Heading .....	16

### 9/06—Revision 0: Initial Version

## SPECIFICATIONS

$V_{CC} = 3.15\text{ V to }26\text{ V}$ ,  $T_A = -40^\circ\text{C to }+85^\circ\text{C}$ , typical values at  $T_A = 25^\circ\text{C}$ , unless otherwise noted.

Table 1.

Parameter	Min	Typ	Max	Unit	Test Conditions/Comments
<b>VCC PIN</b>					
Operating Voltage Range, $V_{CC}$	3.15		26	V	VCC rising
Supply Current, $I_{CC}$		1.7	2	mA	
Undervoltage Lockout, $V_{UVLO}$		2.8		V	
Undervoltage Lockout Hysteresis, $V_{UVLOHYST}$		80		mV	
<b>MONITORING ACCURACY<sup>1</sup></b>					
Current Sense Absolute Accuracy					
0°C to +70°C	-1.45		+1.45	%	$V_{SENSE} = 75\text{ mV}$
	-1.8		+1.8	%	$V_{SENSE} = 50\text{ mV}$
	-2.8		+2.8	%	$V_{SENSE} = 25\text{ mV}$
	-5.7		+5.7	%	$V_{SENSE} = 12.5\text{ mV}$
0°C to +85°C	-1.5		+1.5	%	$V_{SENSE} = 75\text{ mV}$
	-1.8		+1.8	%	$V_{SENSE} = 50\text{ mV}$
	-2.95		+2.95	%	$V_{SENSE} = 25\text{ mV}$
	-6.1		+6.1	%	$V_{SENSE} = 12.5\text{ mV}$
-40°C to +85°C	-1.95		+1.95	%	$V_{SENSE} = 75\text{ mV}$
	-2.45		+2.45	%	$V_{SENSE} = 50\text{ mV}$
	-3.85		+3.85	%	$V_{SENSE} = 25\text{ mV}$
	-6.7		+6.7	%	$V_{SENSE} = 12.5\text{ mV}$
$V_{SENSE}$ for ADC Full Scale <sup>2</sup>		105.84		mV	
Voltage Sense Accuracy					
0°C to +70°C	-0.85		+0.85	%	$V_{CC} = 3.0\text{ V to }5.5\text{ V}$ (low range)
	-0.9		+0.9	%	$V_{CC} = 10.8\text{ V to }16.5\text{ V}$ (high range)
0°C to +85°C	-0.85		+0.85	%	$V_{CC} = 3.0\text{ V to }5.5\text{ V}$ (low range)
	-0.9		+0.9	%	$V_{CC} = 10.8\text{ V to }16.5\text{ V}$ (high range)
-40°C to +85°C	-0.9		+0.9	%	$V_{CC} = 3.0\text{ V to }5.5\text{ V}$ (low range)
	-1.15		+1.15	%	$V_{CC} = 10.8\text{ V to }16.5\text{ V}$ (high range)
$V_{CC}$ for ADC Full Scale <sup>3</sup>					
Low Range ( $VRANGE = 1$ )		6.65		V	
High Range ( $VRANGE = 0$ )		26.52		V	
<b>CLRB PIN</b>					
Logic Low Threshold, $V_{CLRB_L}$			0.8	V	$V_{CLRB} = 0\text{ V to }0.8\text{ V}$
Input Current for Logic Low Input, $I_{CLRB_L}$	-40	-22		$\mu\text{A}$	
Logic High Threshold, $V_{CLRB_H}$	1.6			mV	$V_{CLRB} = 1.6\text{ V to }5.5\text{ V}$
Input Current for Logic High Input, $I_{CLRB_H}$		3	6	$\mu\text{A}$	
<b>ADC CONVERSION TIME<sup>4</sup></b>					
		150		$\mu\text{s}$	
<b>SENSE PIN</b>					
Input Current, $I_{SENSE}$	-1		+1	$\mu\text{A}$	$V_{SENSE} = V_{CC}$
<b>SETV PIN</b>					
Overcurrent Trip Threshold	98	100	102	mV	$V_{SETV} = 1.8\text{ V}$
	49.5	50	50.5	mV	$V_{SETV} = 0.9\text{ V}$
Overcurrent Trip Gain, $V_{SETV}/(V_{CC} - V_{SENSE})$		18			$V_{SETV} = 0.9\text{ V to }1.9\text{ V}$
Input Current, $I_{SETVLEAK}$	-1		+1	$\mu\text{A}$	$V_{SETV} = 0.9\text{ V to }1.9\text{ V}$
Glitch Filter, $t_{SETVGLITCH}$		3		$\mu\text{s}$	

Parameter	Min	Typ	Max	Unit	Test Conditions/Comments
<b>TIMER PIN</b>					
Pull-Up Current (Overcurrent Fault), $I_{TIMERUPOC}$	-46	-62	-78	$\mu\text{A}$	$(18.125 \times V_{SENSE}) > V_{SETV}$ , $V_{TIMER} = 1\text{ V}$
Pull-Down Current, $I_{TIMERDN}$		100		$\mu\text{A}$	Normal operation, $V_{TIMER} = 1\text{ V}$
Pin Threshold High, $V_{TIMERH}$	1.275	1.3	1.325	V	TIMER rising
<b>ALERT PIN</b>					
Output Low Voltage, $V_{ALERTOL}$		0.05	0.1	V	$I_{ALERT} = -100\ \mu\text{A}$
		1	1.5	mA	$I_{ALERT} = -2\ \text{mA}$
Input Current, $I_{ALERT}$	-1		+1	$\mu\text{A}$	$V_{ALERT} = V_{CC}$ ; ALERT asserted
<b>ADR PIN</b>					
Set Address to 00, $V_{ADRL0W}$	0		0.8	V	Low state
Set Address to 01, $R_{ADRL0W}$	80	120	160	k $\Omega$	Resistor to ground state, load pin with specified resistance for 01 decode
Set Address to 10, $I_{ADRHIGH}$	-0.3		+0.3	$\mu\text{A}$	Open state, maximum load allowed on ADR pin for 10 decode
Set Address to 11, $V_{ADRHIGH}$	2		5.5	V	High state
Input Current for 00 Decode, $I_{ADRL0W}$	-40	-25		$\mu\text{A}$	$V_{ADR} = 0\text{ V to }0.8\text{ V}$
Input Current for 11 Decode, $I_{ADRHIGH}$		3	6	$\mu\text{A}$	$V_{ADR} = 2.0\text{ V to }5.5\text{ V}$
<b>I<sup>2</sup>C TIMING</b>					
Low Level Input Voltage, $V_{IL}$			$0.3 V_{BUS}$	V	$V_{BUS} = 3.0\text{ V to }5.5\text{ V}$
High Level Input Voltage, $V_{IH}$	$0.7 V_{BUS}$			V	$V_{BUS} = 3.0\text{ V to }5.5\text{ V}$
Low Level Output Voltage on SDA, $V_{OL}$			0.4	V	$I_{OL} = 3\ \text{mA}$
Output Fall Time on SDA from $V_{IHMIN}$ to $V_{ILMAX}$	$20 + 0.1 C_{BUS}$		250	ns	$C_{BUS} = \text{bus capacitance from SDA to GND}$
Maximum Width of Spikes Suppressed by Input Filtering on SDA Pin and SCL Pin	50		250	ns	
Input Current, $I_I$ , on SDA/SCL When Not Driving a Logic Low Output	-10		+10	$\mu\text{A}$	
Input Capacitance on SDA/SCL		5		pF	
SCL Clock Frequency, $f_{SCL}$			400	kHz	
Low Period of the SCL Clock	600			ns	
High Period of the SCL Clock	1300			ns	
Setup Time for Repeated Start Condition, $t_{SU,STA}$	600			ns	
SDA Output Data Hold Time, $t_{HD,DAT}$	100		900	ns	
Setup Time for a Stop Condition, $t_{SU,STO}$	600			ns	
Bus Free Time Between a Stop and a Start Condition, $t_{BUF}$	1300			ns	
Capacitive Load for Each Bus Line			400	pF	

<sup>1</sup> Monitoring accuracy is a measure of the error in a code that is read back for a particular voltage/current. This is a combination of amplifier error, reference error, ADC error, and error in ADC full-scale code conversion factor.

<sup>2</sup> This is an absolute value to be used when converting ADC codes to current readings; any inaccuracy in this value is factored into absolute current accuracy values (see the Specifications for the Current Sense Absolute Accuracy parameter).

<sup>3</sup> These are absolute values to be used when converting ADC codes to voltage readings; any inaccuracy in these values is factored into voltage accuracy values (see the Specifications for the Voltage Sense Accuracy parameter).

<sup>4</sup> Time between the receipt of the command byte and the actual ADC result being placed in the register.

## ABSOLUTE MAXIMUM RATINGS

Table 2.

Parameter	Rating
VCC Pin	30 V
SENSE Pin	30 V
TIMER Pin	-0.3 V to +6 V
CLRB Pin	-0.3 V to +6 V
SETV Pin	30 V
ALERT Pin	30 V
SDA Pin, SCL Pin	-0.3 V to +6 V
ADR Pin	-0.3 V to +6 V
Storage Temperature Range	-65°C to +125°C
Operating Temperature Range	-40°C to +85°C
Lead Temperature (Soldering 10 sec)	300°C
Junction Temperature	150°C

Stresses above those listed under Absolute Maximum Ratings may cause permanent damage to the device. This is a stress rating only; functional operation of the device at these or any other conditions above those indicated in the operational section of this specification is not implied. Exposure to absolute maximum rating conditions for extended periods may affect device reliability.

## THERMAL CHARACTERISTICS

$\theta_{JA}$  is specified for the worst-case conditions, that is, a device soldered in a circuit board for surface-mount packages.

Table 3. Thermal Resistance

Package Type	$\theta_{JA}$	Unit
10-Lead MSOP	137.5	°C/W

## ESD CAUTION



**ESD (electrostatic discharge) sensitive device.** Charged devices and circuit boards can discharge without detection. Although this product features patented or proprietary protection circuitry, damage may occur on devices subjected to high energy ESD. Therefore, proper ESD precautions should be taken to avoid performance degradation or loss of functionality.

## PIN CONFIGURATION AND FUNCTION DESCRIPTIONS

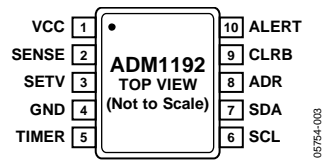

Figure 3. Pin Configuration

Table 4. Pin Function Descriptions

Pin No.	Mnemonic	Description
1	VCC	Positive Supply Input Pin. The operating supply voltage range is 3.15 V to 26 V. An undervoltage lockout (UVLO) circuit resets the ADM1192 when a low supply voltage is detected.
2	SENSE	Current Sense Input Pin. A sense resistor between the VCC pin and the SENSE pin generates a voltage across a sense resistor. This voltage is proportional to the load current. A current sense amplifier amplifies this voltage before it is digitized by the ADC.
3	SETV	Input Pin. The voltage driven onto this pin is compared with the output of the internal current sense amplifier. The lower the voltage on the SETV, the lower the current level that causes the ALERT output to assert. Typical response time is 1 $\mu$ s to 2 $\mu$ s.
4	GND	Chip Ground Pin.
5	TIMER	Timer Input Pin. An external capacitor, $C_{TIMER}$ , sets the timing period for masking overcurrent conditions. This timing period should be sufficient to allow the inrush current to completely charge up the load without tripping an overcurrent fault. This makes the device robust against false triggering due to current transients.
6	SCL	I <sup>2</sup> C Clock Pin. Open-drain input; requires an external resistive pull-up.
7	SDA	I <sup>2</sup> C Data I/O Pin. Open-drain input/output; requires an external resistive pull-up.
8	ADR	I <sup>2</sup> C Address Pin. This pin can be tied low, tied high, left floating, or tied low through a resistor to set four I <sup>2</sup> C addresses.
9	CLR B	Clear Pin. A latched overcurrent condition can be cleared by toggling this pin low. Holding this pin low disables the ALERT output.
10	ALERT	Alert Output Pin. Active high, open-drain configuration. This pin asserts high when an overcurrent condition is present. The level at which an overcurrent condition is detected depends on either the voltage on the SETV pin or the value in the ALERT_TH register. The ALERT_EN register determines which is used in the comparison. This pin has a latching function and must be cleared manually using either the ALERT_EN register or the CLR B pin.

# TYPICAL PERFORMANCE CHARACTERISTICS

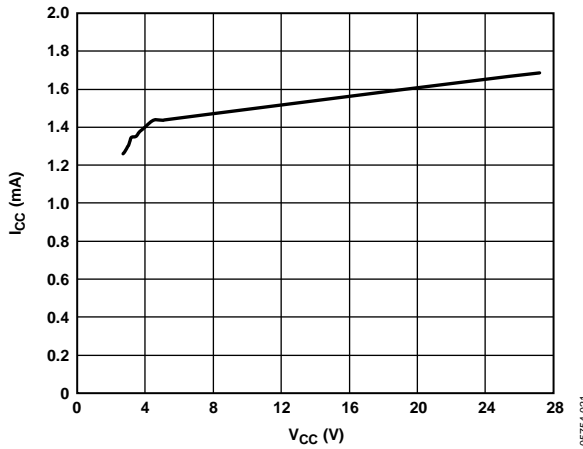

Figure 4. Supply Current vs. Supply Voltage

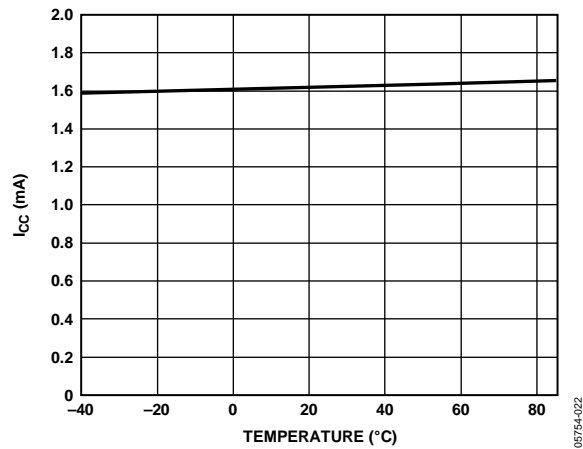

Figure 5. Supply Current vs. Temperature

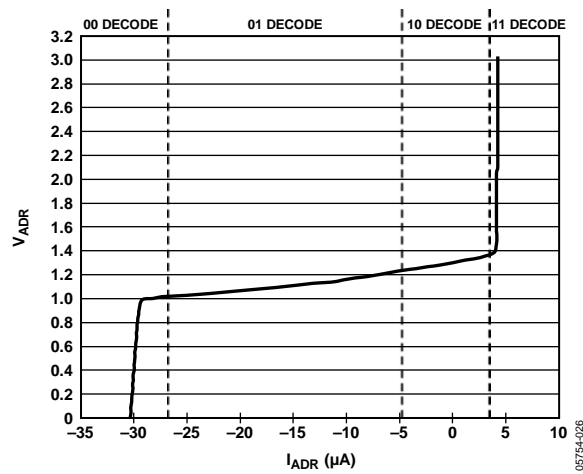

Figure 6. Address Pin Voltage vs. Address Pin Current for Four Addressing Options on Each Address Pin

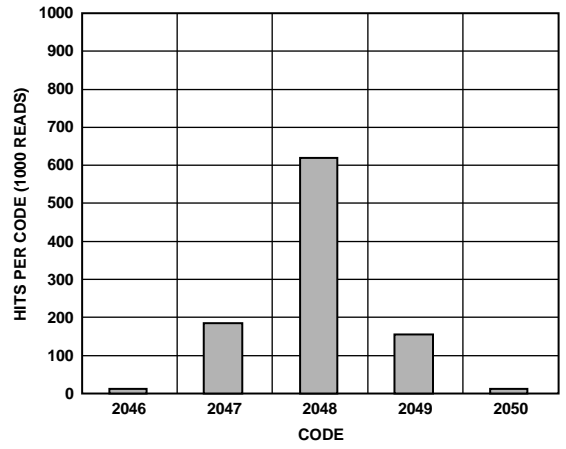

Figure 7. ADC Noise with Current Channel, Midcode Input, and 1000 Reads

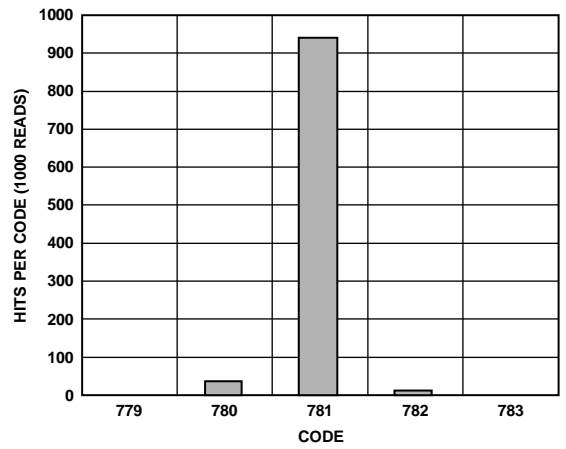

Figure 8. ADC Noise with 14:1 Voltage Channel, 5 V Input, and 1000 Reads

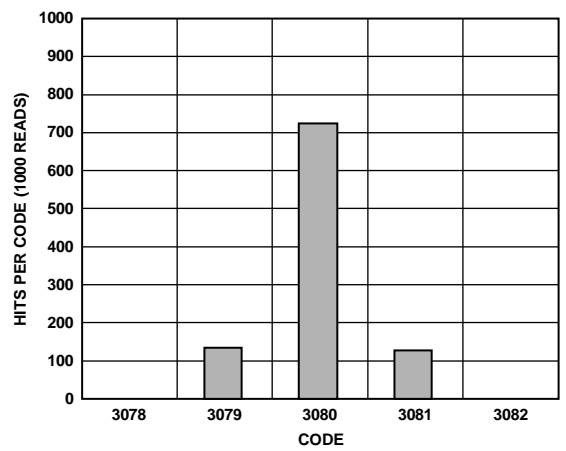

Figure 9. ADC Noise with 7:1 Voltage Channel, 5 V Input, and 1000 Reads

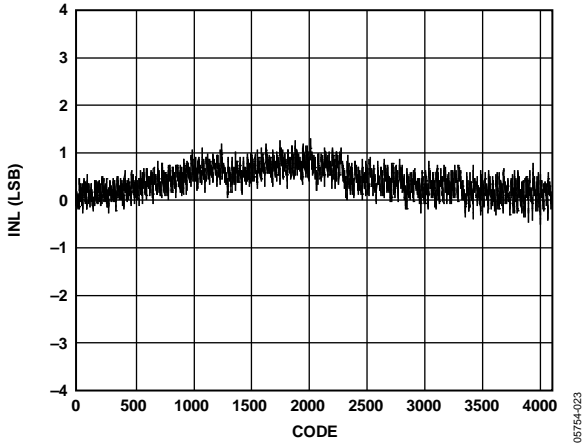

Figure 10. INL for ADC

05754-023

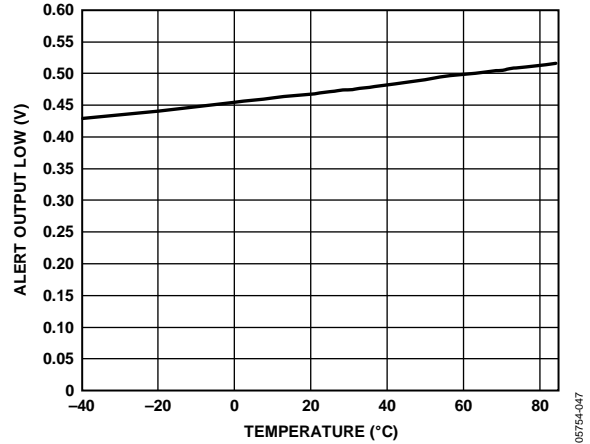

Figure 13. ALERT Output Low Voltage vs. Temperature at 1 mA

05754-047

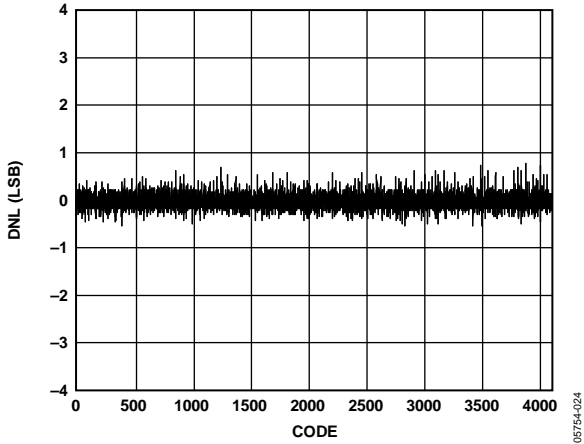

Figure 11. DNL for ADC

05754-024

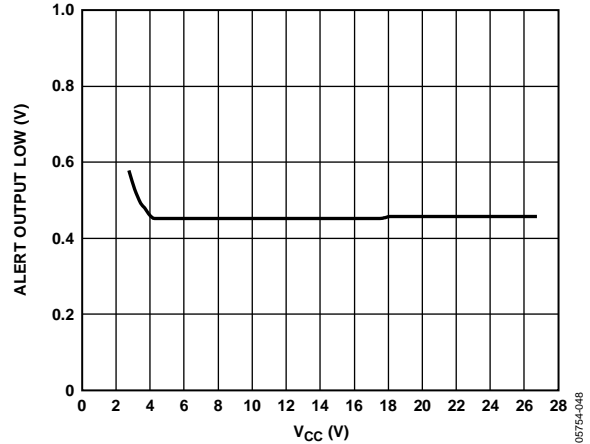

Figure 14. ALERT Output Low Voltage vs. Supply Voltage at 1 mA

05754-048

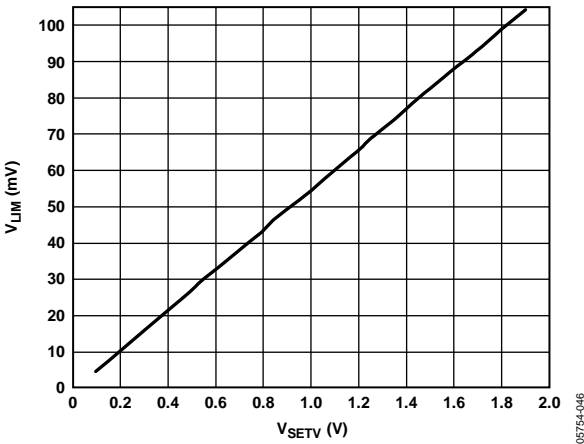

Figure 12. Overcurrent Limit Threshold vs. SETV Pin Voltage

05754-046

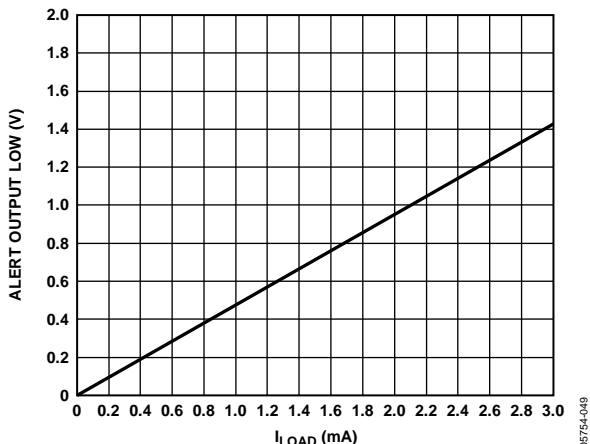
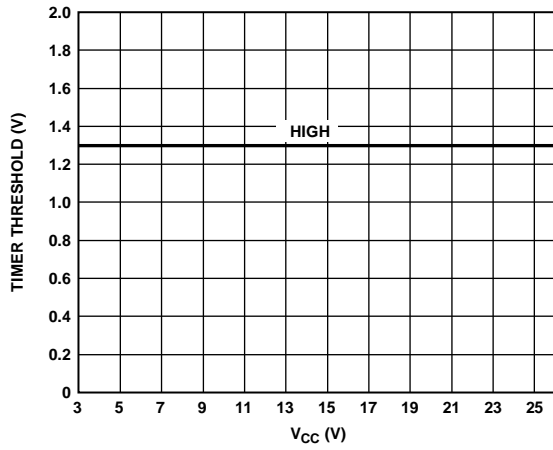

Figure 15. ALERT Output Low Voltage vs. Load Current

05754-049





05754-038

Figure 16. Timer Threshold vs. Supply Voltage

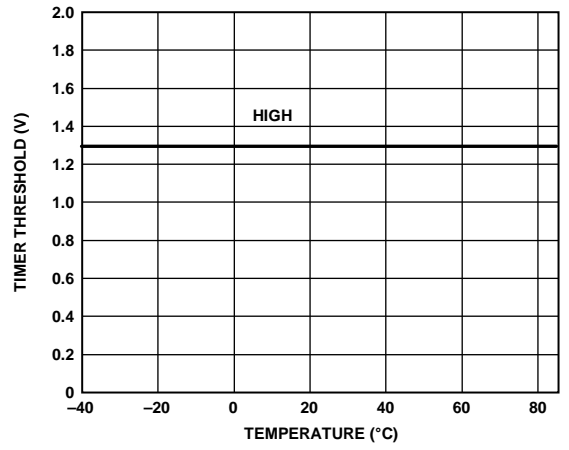

05754-038

Figure 17. Timer Threshold vs. Temperature

## VOLTAGE AND CURRENT READBACK

The ADM1192 contains the components to allow voltage and current readback over an I<sup>2</sup>C bus. The voltage output of the current sense amplifier and the voltage on the VCC pin are fed into a 12-bit ADC via a multiplexer. The device can be instructed to convert voltage and/or current at any time during operation via an I<sup>2</sup>C command. When all conversions are complete, the voltage and/or current values can be read back with 12-bit accuracy in two or three bytes.

### SERIAL BUS INTERFACE

Control of the ADM1192 is carried out via the serial system management bus (I<sup>2</sup>C). This interface is compatible with the I<sup>2</sup>C fast mode (400 kHz maximum). The ADM1192 is connected to this bus as a slave device, under the control of a master device.

### IDENTIFYING THE ADM1192 ON THE I<sup>2</sup>C BUS

The ADM1192 has a 7-bit serial bus slave address. When the device powers up, it does so with a default serial bus address. The five MSBs of the address are set to 01011; the two LSBs are determined by the state of the ADR pin. There are four configurations available on the ADR pin that correspond to four I<sup>2</sup>C addresses for the two LSBs (see Table 5). This scheme allows four ADM1192 devices to operate on a single I<sup>2</sup>C bus.

### GENERAL I<sup>2</sup>C TIMING

Figure 18 and Figure 19 show timing diagrams for general write and read operations using the I<sup>2</sup>C. The I<sup>2</sup>C specification defines conditions for different types of read and write operations, which are discussed in the Write and Read Operations section. The general I<sup>2</sup>C protocol operates as follows:

1. The master initiates a data transfer by establishing a start condition, defined as a high-to-low transition on the serial data line, SDA, while the serial clock line, SCL, remains high. This indicates that a data stream is to follow. All slave peripherals connected to the serial bus respond to the start condition and shift in the next eight bits, consisting of a 7-bit slave address (MSB first) plus an R/W bit that determines the direction of the data transfer, that is, whether data is written to or read from the slave device (0 = write, 1 = read).

The peripheral whose address corresponds to the transmitted address responds by pulling the data line low during the low period before the ninth clock pulse, known as the acknowledge bit, and holding it low during the high period of this clock pulse. All other devices on the bus now remain idle while the selected device waits for data to be read from it or written to it. If the R/W bit is 0, the master writes to the slave device. If the R/W bit is 1, the master reads from the slave device.

2. Data is sent over the serial bus in sequences of nine clock pulses: eight bits of data followed by an acknowledge bit from the slave device. Data transitions on the data line must occur during the low period of the clock signal and remain stable during the high period because a low-to-high transition when the clock is high can be interpreted as a stop signal.

If the operation is a write operation, the first data byte after the slave address is a command byte. This tells the slave device what to expect next. It can be an instruction, such as telling the slave device to expect a block write, or it can be a register address that tells the slave where subsequent data is to be written.

Because data can flow in only one direction, as defined by the R/W bit, it is not possible to send a command to a slave device during a read operation. Before performing a read operation, it may be necessary to first execute a write operation to tell the slave what sort of read operation to expect and/or the address from which data is to be read.

3. When all data bytes are read or written, stop conditions are established. In write mode, the master pulls the data line high during the 10<sup>th</sup> clock pulse to assert a stop condition. In read mode, the master device releases the SDA line during the SCL low period before the ninth clock pulse, but the slave device does not pull it low. This is known as a no acknowledge. The master then takes the data line low during the SCL low period before the 10<sup>th</sup> clock pulse, and then high during the 10<sup>th</sup> clock pulse to assert a stop condition.

Table 5. Setting I<sup>2</sup>C Addresses via the ADR Pin

Base Address	ADR Pin State	ADR Pin Logic State	Address in Binary <sup>1</sup>	Address in Hex
01011	Ground	00	0101100X	0x58
	Resistor to ground	01	0101101X	0x5A
	Floating	10	0101110X	0x5C
	High	11	0101111X	0x5E

<sup>1</sup> X = don't care.

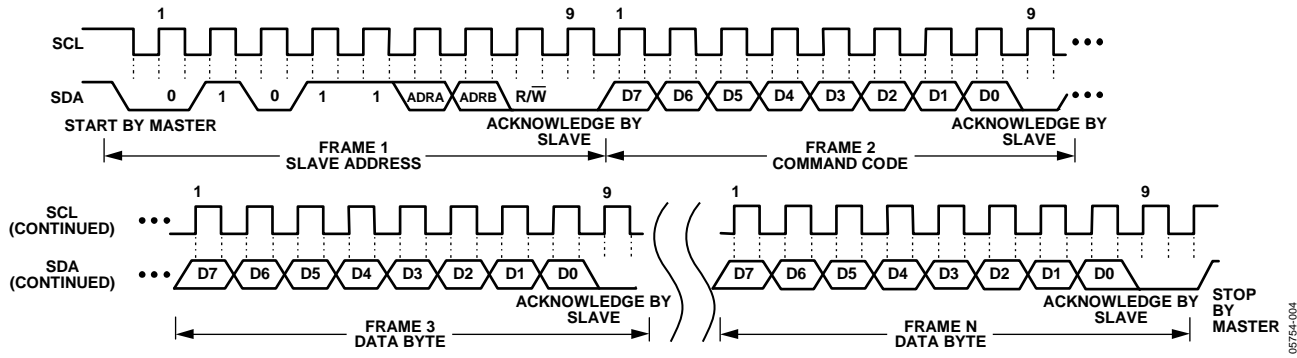

Figure 18. General I<sup>2</sup>C Write Timing Diagram

05754-004

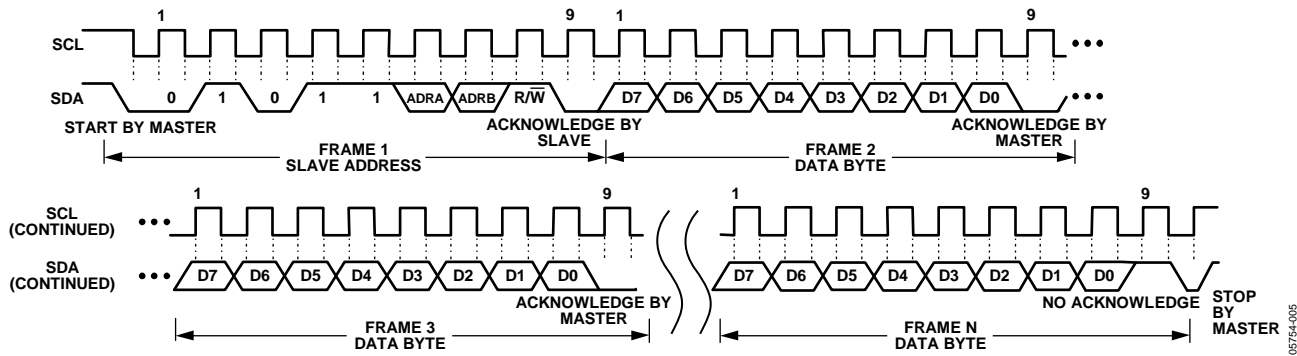

Figure 19. General I<sup>2</sup>C Read Timing Diagram

05754-005

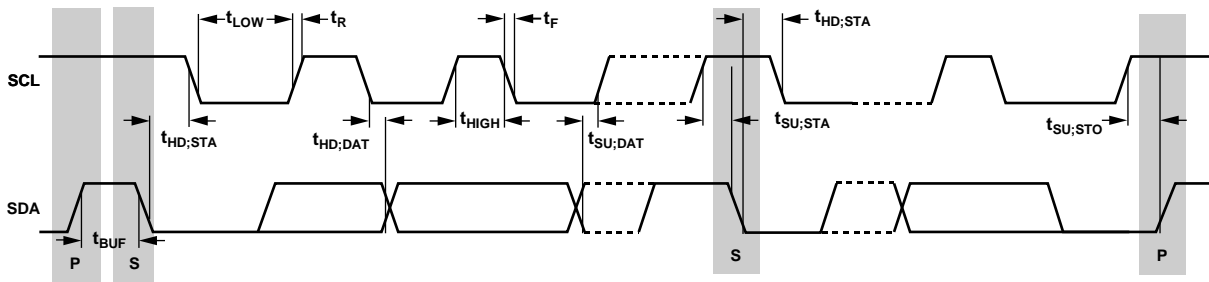

Figure 20. Serial Bus Timing Diagram

05754-006

## WRITE AND READ OPERATIONS

The I<sup>2</sup>C specification defines several protocols for different types of read and write operations. The operations used in the ADM1192 are discussed in this section. Table 6 shows the abbreviations used in the command diagrams (see Figure 21 to Figure 26).

Table 6. I<sup>2</sup>C Abbreviations

Abbreviation	Condition
S	Start
P	Stop
R	Read
W	Write
A	Acknowledge
N	No acknowledge

### QUICK COMMAND

The quick command operation allows the master to check if the slave is present on the bus, as follows:

1. The master device asserts a start condition on SDA.
2. The master sends the 7-bit slave address, followed by the write bit (low).
3. The addressed slave device asserts an acknowledge on SDA.
4. The master asserts a stop condition on SDA to end the transaction.

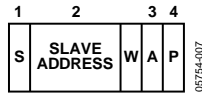

Figure 21. Quick Command

### WRITE COMMAND BYTE

In the write command byte operation, the master device sends a command byte to the slave device, as follows:

1. The master device asserts a start condition on SDA.
2. The master sends the 7-bit slave address, followed by the write bit (low).
3. The addressed slave device asserts an acknowledge on SDA.
4. The master sends the command byte. The command byte is identified by an MSB = 0. An MSB = 1 indicates an extended register write (see the Write Extended Command Byte section).
5. The slave asserts an acknowledge on SDA.
6. The master asserts a stop condition on SDA to end the transaction.

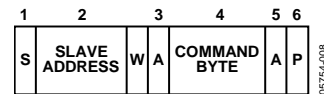

Figure 22. Write Command Byte

The seven LSBs of the command byte are used to configure and control the ADM1192. Table 7 provides details of the function of each bit.

Table 7. Command Byte Operations

Bit	Default	Name	Function
C0	0	V_CONT	LSB, set to convert voltage continuously. If readback is attempted before the first conversion is complete, the ADM1192 asserts an acknowledge and returns all 0s in the returned data.
C1	0	V_ONCE	Set to convert voltage once. Self-clears. I <sup>2</sup> C asserts a no acknowledge on attempted reads until the ADC conversion is complete.
C2	0	I_CONT	Set to convert current continuously. If readback is attempted before the first conversion is complete, the ADM1192 asserts an acknowledge and returns all 0s in the returned data.
C3	0	I_ONCE	Set to convert current once. Self-clears. I <sup>2</sup> C asserts a no acknowledge on attempted reads until the ADC conversion is complete.
C4	0	VRANGE	Selects different internal attenuation resistor networks for voltage readback. A 0 in C4 selects a 14:1 voltage divider. A 1 in C4 selects a 7:2 voltage divider. With an ADC full scale of 1.902 V, the voltage at the VCC pin for an ADC full-scale result is 26.52 V for VRANGE = 0 and 6.65 V for VRANGE = 1.
C5	0	Not applicable	Unused.
C6	0	STATUS_RD	Status Read. When this bit is set, the data byte read back from the ADM1192 is the status byte. This contains the status of the device alerts. See Table 15 for full details of the status byte.

## WRITE EXTENDED COMMAND BYTE

In the write extended command byte operation, the master device writes to one of the three extended registers of the slave device, as follows:

1. The master device asserts a start condition on SDA.
2. The master sends the 7-bit slave address, followed by the write bit (low).
3. The addressed slave device asserts an acknowledge on SDA.
4. The master sends the register address byte. The MSB of this byte is set to 1 to indicate an extended register write. The two LSBs indicate which of the three extended registers are to be written to (see Table 8). All other bits should be set to 0.
5. The slave asserts an acknowledge on SDA.
6. The master sends the extended command byte (refer to Table 9, Table 10, and Table 11).

7. The slave asserts an acknowledge on SDA.
8. The master asserts a stop condition on SDA to end the transaction.

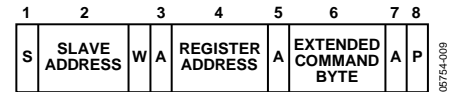

Figure 23. Write Extended Byte

Table 9, Table 10, and Table 11 provide the details of each extended register.

Table 8. Extended Register Addresses

A6	A5	A4	A3	A2	A1	A0	Extended Register
0	0	0	0	0	0	1	ALERT_EN
0	0	0	0	0	1	0	ALERT_TH
0	0	0	0	0	1	1	CONTROL

Table 9. ALERT\_EN Register Operations

Bit	Default	Name	Function
0	0	EN_ADC_OC1	LSB, enabled if a single ADC conversion on the I channel exceeds the threshold set in the ALERT_TH register.
1	0	EN_ADC_OC4	Enabled if four consecutive ADC conversions on the I channel exceed the threshold set in the ALERT_TH register.
2	1	EN_OC_ALERT	Enables the OC_ALERT register. If an overcurrent condition is present compared to the SETV threshold, and the TIMER pin charges to 1.3 V, the OC_ALERT register captures and latches this condition.
3	0	EN_OFF_ALERT	Enables an alert if the hot swap operation is turned off by an operation that writes the SWOFF bit high. This allows a software override of the ALERT output and turns on a P-channel FET controlled by ALERT.
4	0	CLEAR	Clears the OC_ALERT and ADC_ALERT status bits in the status register. The value of these bits can immediately change if the source of the alert is not cleared and the alert function is not disabled. The CLEAR bit self-clears to 0 after the STATUS register bits are cleared.

Table 10. ALERT\_TH Register Operations

Bit	Default	Function
[7:0]	FF	The ALERT_TH register sets the current level at which an alert occurs. Defaults to ADC full scale. The ALERT_TH 8-bit value corresponds to the top eight bits of the current channel data.

Table 11. CONTROL Register Operations

Bit	Default	Name	Function
0	0	SWOFF	LSB, forces the ALERT pin to deassert. Can be active only if the EN_OFF_ALERT bit is high (see Table 9).

## READ VOLTAGE AND/OR CURRENT DATA BYTES

Depending on how the device is configured, the [ADM1192](#) can be set up to provide information in three ways after a conversion (or conversions): voltage and current readback, voltage only readback, and current only read back. See the Write Command Byte section for more details.

### Voltage and Current Readback

The [ADM1192](#) digitizes both voltage and current. Three bytes are read back in the format shown in Table 12.

**Table 12. Voltage and Current Readback Format**

Byte	Contents	B7	B6	B5	B4	B3	B2	B1	B0
1	Voltage MSBs	V11	V10	V9	V8	V7	V6	V5	V4
2	Current MSBs	I11	I10	I9	I8	I7	I6	I5	I4
3	Current LSBs	V3	V2	V1	V0	I3	I2	I1	I0

### Voltage Readback

The [ADM1192](#) digitizes voltage only. Two bytes are read back in the format shown in Table 13.

**Table 13. Voltage Only Readback Format**

Byte	Contents	B7	B6	B5	B4	B3	B2	B1	B0
1	Voltage MSBs	V11	V10	V9	V8	V7	V6	V5	V4
2	Voltage LSBs	V3	V2	V1	V0	0	0	0	0

### Current Readback

The [ADM1192](#) digitizes current only. Two bytes are read back in the format shown in Table 14.

**Table 14. Current Only Readback Format**

Byte	Contents	B7	B6	B5	B4	B3	B2	B1	B0
1	Current MSBs	I11	I10	I9	I8	I7	I6	I5	I4
2	Current LSBs	I3	I2	I1	I0	0	0	0	0

The following series of events occurs when the master receives three bytes (voltage and current data) from the slave device:

1. The master device asserts a start condition on SDA.
2. The master sends the 7-bit slave address, followed by the read bit (high).
3. The addressed slave device asserts an acknowledge on SDA.
4. The master receives the first data byte.
5. The master asserts an acknowledge on SDA.
6. The master receives the second data byte.
7. The master asserts an acknowledge on SDA.
8. The master receives the third data byte.
9. The master asserts a no acknowledge on SDA.
10. The master asserts a stop condition on SDA, and the transaction ends.

For cases where the master is reading voltage only or current only, two data bytes are read and Step 7 and Step 8 are not required.

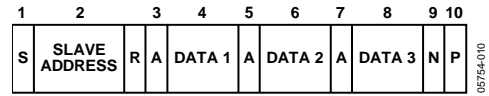

Figure 24. Three-Byte Read from [ADM1192](#)

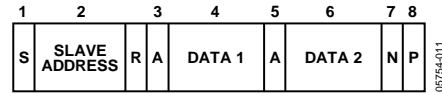

Figure 25. Two-Byte Read from [ADM1192](#)

## Converting ADC Codes to Voltage and Current Readings

Equation 1 and Equation 2 can be used to convert ADC codes representing voltage and current from the [ADM1175](#) 12-bit ADC into actual voltage and current values.

$$Voltage = (V_{FULLSCALE}/4096) \times Code \quad (1)$$

where:

$V_{FULLSCALE}$  = 6.65 V (7:2 range) or 26.52 V (14:1 range).

$Code$  is the ADC voltage code read from the device (Bit V11 to Bit V0).

$$Current = ((I_{FULLSCALE}/4096) \times Code)/Sense\ Resistor \quad (2)$$

where:

$I_{FULLSCALE}$  = 105.84 mV.

$Code$  is the ADC current code read from the device (Bit I11 to Bit I0).

## Read Status Register

A single register of status data can also be read from the [ADM1192](#) as follows:

1. The master device asserts a start condition on SDA.
2. The master sends the 7-bit slave address, followed by the read bit (high).
3. The addressed slave device asserts an acknowledge on SDA.
4. The master receives the status byte.
5. The master asserts an acknowledge on SDA.

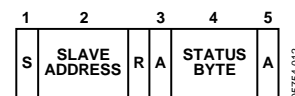

Figure 26. Status Read from [ADM1192](#)

Table 15 shows the [ADM1192](#) STATUS registers in detail. Note that Bit 1, Bit 3, and Bit 5 are cleared by writing to Bit 4 (the CLEAR bit) of the ALERT\_EN register.

Table 15. Status Byte Operations

Bit	Name	Function
0	ADC_OC	An ADC-based overcurrent comparison has been detected on the last three conversions.
1	ADC_ALERT	An ADC-based overcurrent trip has occurred, causing the alert. Cleared by writing to Bit 4 of the ALERT_EN register.
2	OC	An overcurrent condition is present (that is, the output of the current sense amplifier is greater than the voltage on the SETV input).
3	OC_ALERT	An overcurrent condition has caused the ALERT block to latch a fault, and the ALERT output has asserted. Cleared by writing to Bit 4 of the ALERT_EN register or by toggling the CLR pin low.
4	OFF_STATUS	Set to 1 by writing to the SWOFF bit of the CONTROL register.
5	OFF_ALERT	An alert has been caused by the SWOFF bit. Cleared by writing to Bit 4 of the ALERT_EN register.

## APPLICATIONS INFORMATION

### ALERT OUTPUT

The ALERT output is an open-drain pin with 30 V tolerance. There are two uses for this output.

#### Overcurrent Flag

The ALERT pin can be connected to the general-purpose logic input of a controller. During normal operation, the ADM1192 drives this output low. When an overcurrent condition occurs, the output asserts high. An external pull-up resistor should be used. This pin is configured by default to trigger the SETV threshold at power-up.

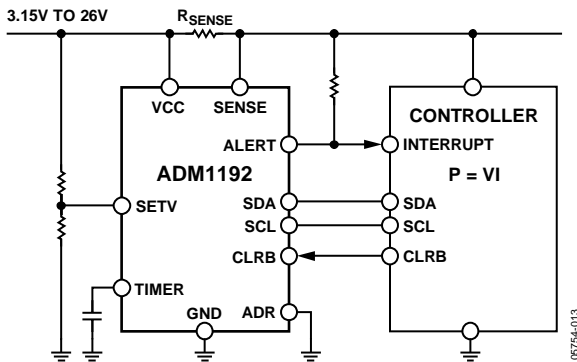

Figure 27. Using the ALERT Output as an Interrupt

#### Implementing a Basic Hot Swap Circuit

A basic P-channel FET hot swap circuit can be created. The ALERT output should be connected to the GATE pin of a P-channel FET connected in series with the power path. A pull-up from GATE to source ensures that the P-channel FET GATE is pulled up and the device held off as soon as power is applied. When the ADM1192 powers up, the GATE is pulled low by the ALERT output. A capacitor on the ALERT pin determines the slew rate of the GATE pin at startup. Note that, if a current fault occurs during the operation, the ALERT output asserts high, turning off the P-channel FET.

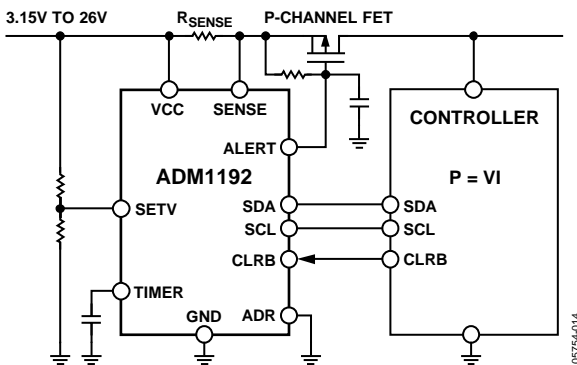

Figure 28. P-Channel FET Hot Swap Implementation

### SETV PIN

The SETV pin allows the user to adjust the current level that trips the ALERT output. The output of the current sense amplifier is compared with the voltage driven onto the SETV pin. If the current sense amplifier output is higher than the SETV voltage, the output of the comparator asserts. By driving a different voltage onto the SETV pin, the ADM1192 detects an overcurrent condition at a different current level, with a gain of 18. The 100 mV ADC full-scale sense voltage corresponds to 1.8 V on the SETV pin. See Figure 12 for an illustration of this relationship.

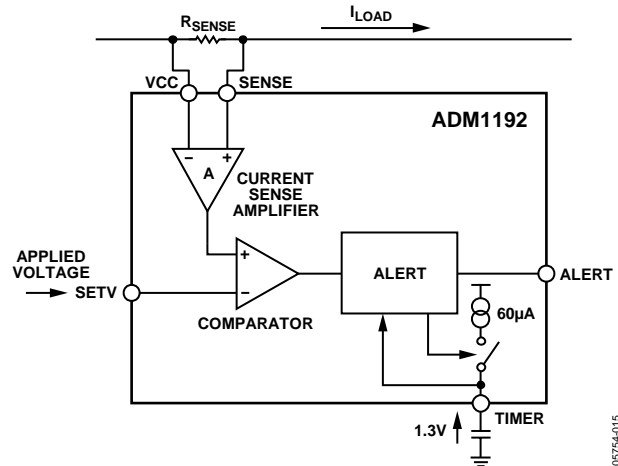

Figure 29. SETV Operation

When the output of the SETV comparator asserts, this tells the ALERT block to begin charging the external TIMER capacitor with a 62 µA charging current. When the voltage on the TIMER capacitor reaches 1.3 V, the charging cycle is complete. The ALERT output then asserts (goes high). Different values of TIMER capacitor generate different time delays between current faults occurring and the ALERT output asserting. When using the ALERT output to implement a hot swap circuit, the TIMER capacitor should be chosen to generate a large enough startup delay to allow the maximum inrush current to completely charge up the load without tripping an ALERT fault.

#### KELVIN SENSE RESISTOR CONNECTION

When using a low value sense resistor for high current measurement, the problem of parasitic series resistance can arise. The pad and solder resistance can be a substantial fraction of the rated resistance, making the total resistance larger than expected.

This error problem can be largely avoided by using a Kelvin sense connection. This type of connection separates the high current path through the resistor and the voltage drop across the resistor. A four pad resistor may be used or a split pad layout can be used with a two pad sense resistor to achieve Kelvin sensing.



# OUTLINE DIMENSIONS

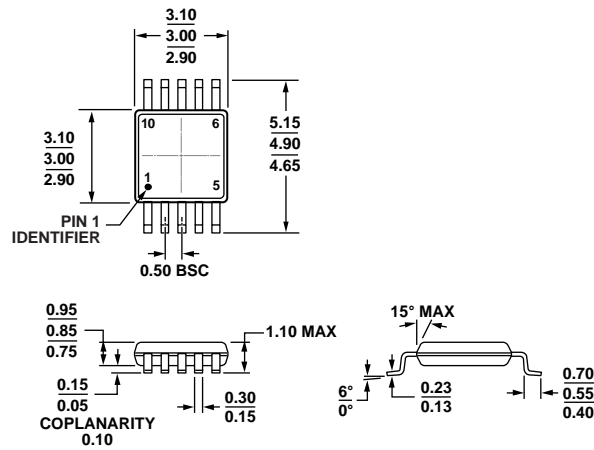

COMPLIANT TO JEDEC STANDARDS MO-187-BA

Figure 30. 10-Lead Mini Small Outline Package [MSOP] (RM-10)

Dimensions shown in millimeters

001700-A

## ORDERING GUIDE

Model <sup>1</sup>	Temperature Range	Package Description	Package Option	Branding
ADM1192-1ARMZ-R7	-40°C to +85°C	10-Lead MSOP	RM-10	M5M
EVAL-ADM1192EBZ		Evaluation Board		

<sup>1</sup> Z = RoHS Compliant Part.

**NOTES**

**NOTES**

**NOTES**

I<sup>2</sup>C refers to a communications protocol originally developed by Philips Semiconductors (now NXP Semiconductors).

## Данный компонент на территории Российской Федерации

### Вы можете приобрести в компании MosChip.

Для оперативного оформления запроса Вам необходимо перейти по данной ссылке:

<http://moschip.ru/get-element>

Вы можете разместить у нас заказ для любого Вашего проекта, будь то серийное производство или разработка единичного прибора.

В нашем ассортименте представлены ведущие мировые производители активных и пассивных электронных компонентов.

Нашей специализацией является поставка электронной компонентной базы двойного назначения, продукции таких производителей как XILINX, Intel (ex.ALTERA), Vicor, Microchip, Texas Instruments, Analog Devices, Mini-Circuits, Amphenol, Glenair.

Сотрудничество с глобальными дистрибьюторами электронных компонентов, предоставляет возможность заказывать и получать с международных складов практически любой перечень компонентов в оптимальные для Вас сроки.

На всех этапах разработки и производства наши партнеры могут получить квалифицированную поддержку опытных инженеров.

Система менеджмента качества компании отвечает требованиям в соответствии с ГОСТ Р ИСО 9001, ГОСТ РВ 0015-002 и ЭС РД 009

### Офис по работе с юридическими лицами:

105318, г.Москва, ул.Щербаковская д.3, офис 1107, 1118, ДЦ «Щербаковский»

Телефон: +7 495 668-12-70 (многоканальный)

Факс: +7 495 668-12-70 (доб.304)

E-mail: [info@moschip.ru](mailto:info@moschip.ru)

Skype отдела продаж:

moschip.ru

moschip.ru\_4

moschip.ru\_6

moschip.ru\_9