

### FEATURES

- ◆ Ultra Broad Bandwidth: 50 MHz to 50 GHz
- ◆ Functional Bandwidth : 50 MHz to 70 GHz
- ◆ 0.5 dB Insertion Loss at 50GHz
- ◆ 46 dB Isolation at 50 GHz
- ◆ Low Current consumption.
  - -10mA /1.35V for low loss state
  - +10mA /1.35V for Isolation state
- ◆ Silicon Nitride Passivation
- ◆ Polymer Scratch protection
- ◆ RoHS Compliant

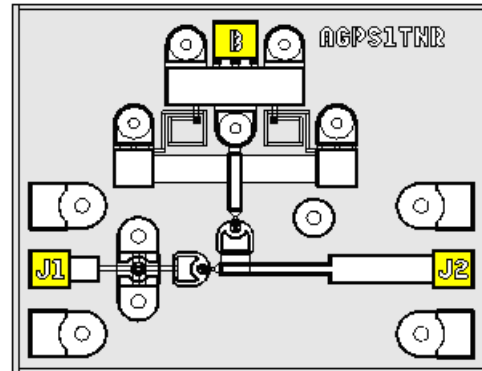

### DESCRIPTION

M/A-COM's, MA4AGSW1A is an Aluminum-Gallium-Arsenide, single pole, single throw (SPST), absorptive PIN diode switch. The switch features enhanced AlGaAs anodes which are formed using M/A-COM's patented hetero-junction technology. AlGaAs technology produces a switch with less loss than a device fabricated using conventional GaAs processes. As much as a 0.3dB reduction in insertion loss can be realized at 50GHz. This device is fabricated on an OMCVD epitaxial wafer using a process designed for high device uniformity and extremely low parasitics. The PIN diodes within the chip exhibit low series resistance, low capacitance, and fast switching speed. They are fully passivated with silicon nitride and have an additional polymer layer for scratch protection. The protective coating prevents damage during handling and assembly to the diode junction as well as the anode air-bridges. Off chip bias circuitry will be required.

Yellow areas indicate bond pads

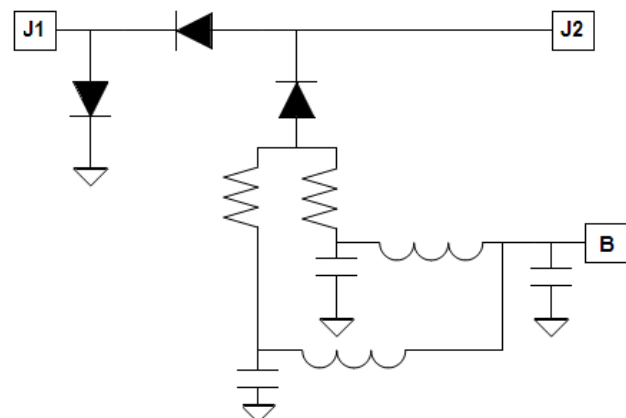

### APPLICATIONS

The output port of this device, J2, is terminated into 50Ω during isolation mode, which allows this signal to be absorbed rather than reflected back. This functionality makes it ideal for instrumentation and radar applications. An absorptive switch can be added to other AlGaAs reflective switches to improve isolation VSWR and increase isolation magnitude. The ultra low capacitance of the PIN diodes makes it ideal for usage in low loss and high isolation microwave and millimeter wave switch designs through 70 GHz. The lower series resistance of the AlGaAs diodes reduces the total insertion loss and distortion of the device. AlGaAs PIN switches are used in applications such as switching arrays for radar systems, radiometers, and other multi-function components.

### Absolute Maximum Ratings @ T<sub>AMB</sub> = +25°C

Parameter	Maximum Rating
Operating Temperature	-55°C to +125°C
Storage Temperature	-55°C to +150°C
Incident C.W. RF Power	+23dBm C.W.
Breakdown Voltage	25V
Bias Current	± 25mA
Assembly Temperature	+300°C < 10 sec
Junction Temperature	+175°C

Maximum combined operating conditions for RF Power, D.C. bias, and temperature: +23 dBm C.W. @ 10 mA (per diode) @ +85°C.

**Electrical Specifications @ T<sub>AMB</sub> = 25°C  
(On-wafer measurements)**

Parameter	Ports	Bias Conditions	Frequency	Typical
Insertion Loss	J1 - J2	Bias J1 — -1.35V/10mA	50Ghz	1.2dB
		Bias B — -1.35V/0mA		
Isolation	J1 - J2	Port J1 — +1.35V/10mA	50Ghz	30dB
		Bias B — +1.35V/10mA		
Input return Loss	J1- J2 (Terminated by 50Ω)	Port J1 — -1.35V/10mA	50Ghz	15dB
		Bias B — -1.35V/0mA		
Output Return Loss (Insertion loss))	J2- J1 (Terminated by 50Ω)	Port J1 — -1.35V/10mA	50Ghz	18dB
		Bias B — -1.35V/0mA		
Output Return Loss (Isolation)	J2	Port J1 — +1.35V/10mA	50Ghz	18dB
		Bias B — +1.35V/10mA		
Switching Speed (10% - 90% RF Voltage)	J1 - J2	±5V PIN TTL Driver	10GHz	10nS
		1MHz Repetition Frequency.		

**Notes:**

1. Typical switching speed is measured from 10% to 90% of the detected RF voltage driven by a TTL compatible driver. Driver output parallel RC network uses a capacitor between 390 pF - 560 pF and a resistor between 150 - 220 Ohms to achieve 10 ns rise and fall times.
2. Bias nodes, J1 and B may be connected together

### Typical RF Performance (Probed on Wafer)

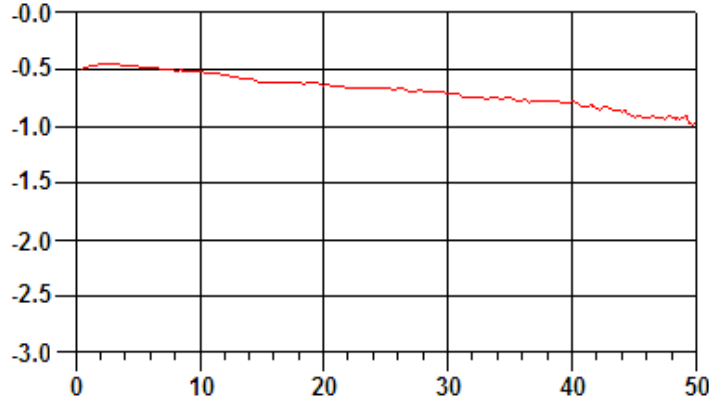

### Isolation

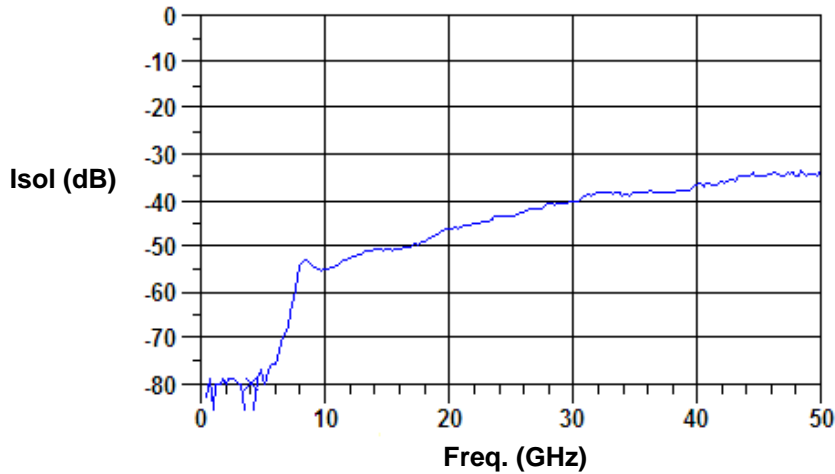

### Input Return Loss

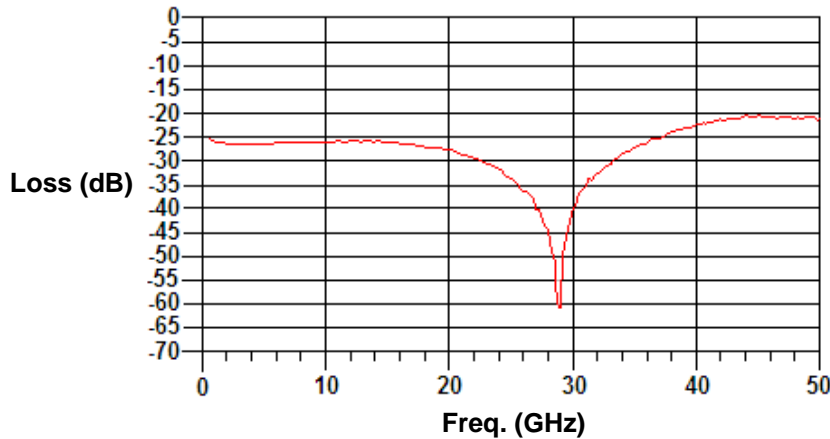

## Typical RF Performance (Probed on wafer)

### Output Return Loss (Insertion Loss State)

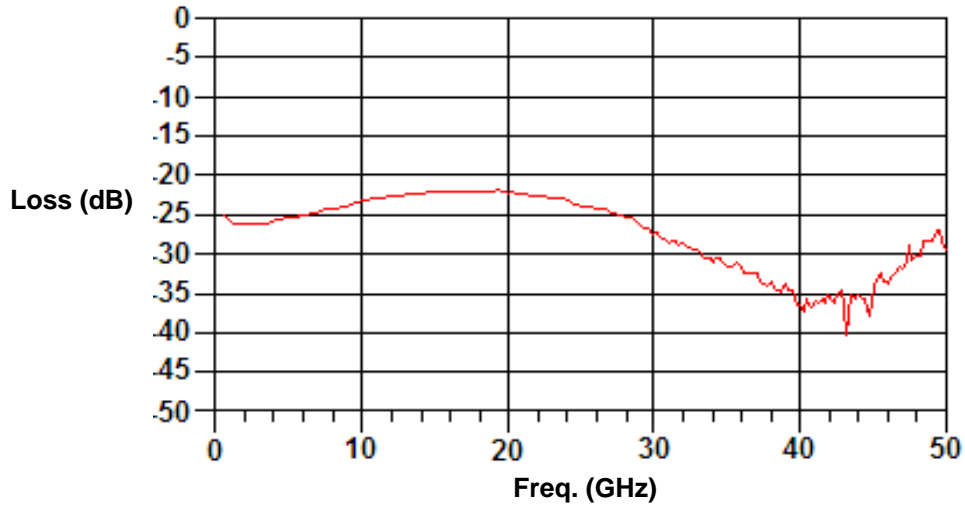

### Output Return Loss (Isolation Loss State)

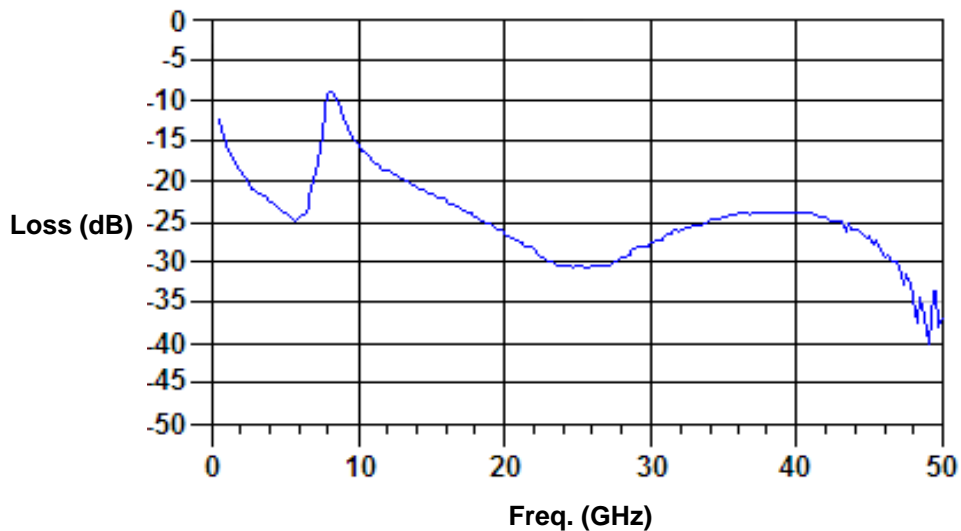

### Operation of the MA4AGSW1A Switch

An external bias network and D.C return is required for successful operation of the MA4AGSW1A absorptive SPST AlGaAs PIN diode switch. The backside area of the die is the RF and D.C. ground return plane. In the low loss state, the series diode is forward biased with negative current at D.C. Bias 1 and the match diode is biased at 0V at D.C. Bias B. In the isolated state, the shunt diode and the match diode are both forward biased at D.C. Bias B1 and D.C. Bias B (series diode becomes reverse biased ). This isolation state bias results in a good 50Ω match into Port J2. Typical driver connections are shown in Table I below. The bias network design shown in the schematic should yield > 30dB RF to DC isolation.

### MA4AGSW1A Schematic with Bias Network for 10-30Ghz

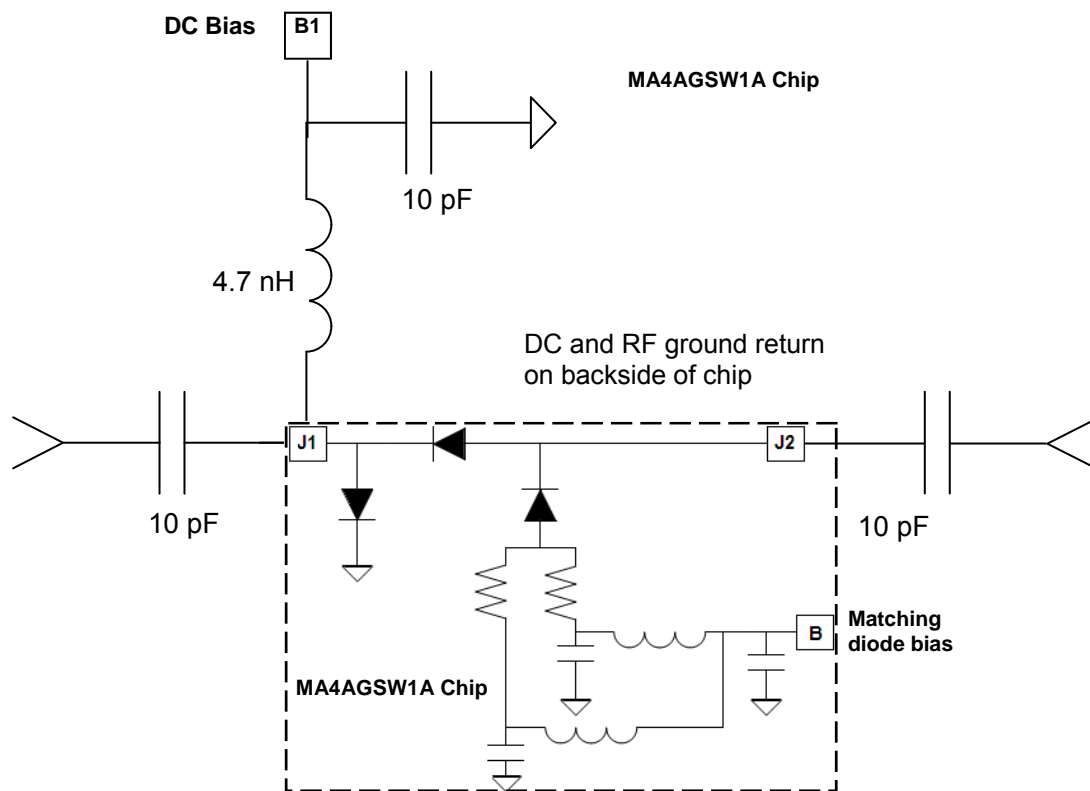

**Notes:**

1. D.C. Bias 1 and D.C. Bias B nodes can be connected together.
2. Diode junction forward bias voltage,  $\Delta V_f @ 10 \text{ mA} \sim 1.35 \text{ V} @ + 25^\circ \text{ C}$ .

### TYPICAL DRIVER CONNECTIONS

J1-J2 Low Loss : Good VSWR at J1 & J2	J1-J2 Isolation : Good VSWR at J2
D.C. Bias 1 = -10mA	D.C. Bias 1 = +10mA
D.C. Bias B = 0V	D.C. Bias B = +10mA

## Chip Dimensions and Bonding Pad Locations (In Yellow)

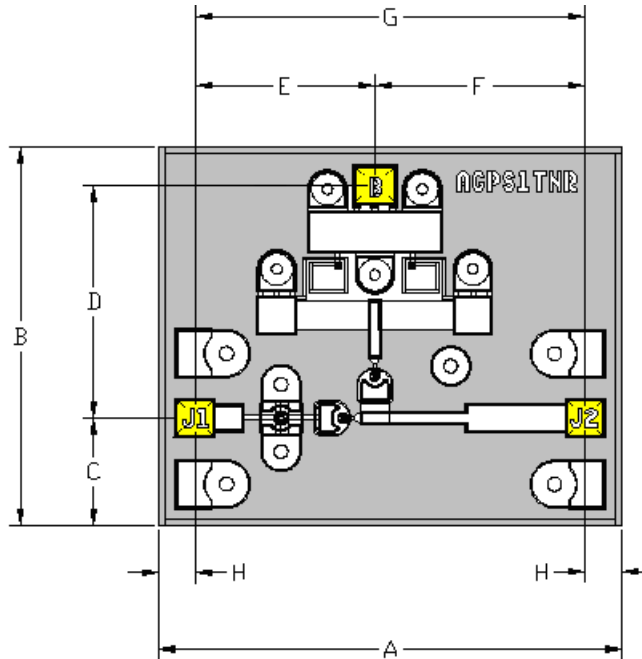

Dimension	mils		mm	
	Min	Max	Min	Max
A	44.9	46.9	1.14	1.19
B	36.9	38.9	0.94	0.99
C	10.4	11.4	0.26	0.29
D	22.8	23.4	0.58	0.59
E	17.3	17.9	0.44	0.45
F	20.3	20.9	0.52	0.53
G	37.9	38.5	0.96	0.98
H	3.4	4.4	0.09	0.11
Thickness	3.5	4.5	0.09	0.11
Bond Pads J1 & J2	3.9 X 3.9	4.1 X 4.1	.099 X .099	.104 X .104
Bond Pad B	3.9 X 4.2	4.1 X 4.4	.099 X .107	.104 X .112

## ASSEMBLY INSTRUCTIONS

### CLEANLINESS

These chips should be handled in a clean environment.

### STATIC SENSITIVITY

These Devices are considered ESD Class 1A, HBM. Proper ESD techniques should be used when handling these devices.

### GENERAL HANDLING

The protective polymer coating on the active areas of the die provides scratch and impact protection, particularly for the metal air bridge, which contacts the diode's anode. Die should primarily be handled with vacuum pickup tools, or alternatively with plastic tweezers.

## ASSEMBLY TECHNIQUES

The MA4AGSW1A, AlGaAs device is designed to be mounted with electrically conductive silver epoxy or with a low temperature solder perform, which does not have a rich tin content.

### SOLDER DIE ATTACH

Only solders which do not scavenge gold, such as 80Au/Sn20, or Indalloy #2 is recommended. Do not expose die to temperatures greater than 300°C for more than 10 seconds.

### ELECTRICAL CONDUCTIVE EPOXY DIE ATTACH

Use a controlled thickness of approximately 2 mils for best electrical conductivity and lowest thermal resistance. Cure epoxy per manufacturer's schedule. Typically 150°C for 1 hour.

### RIBBON/WIRE BONDING

Thermo-compression wedge or ball bonding may be used to attach ribbons or wire to the gold bonding pads. A 1/4 x 3 mil gold ribbon is recommended on all RF ports and should be kept as short as possible for the lowest inductance and best microwave performance. For more detailed handling and assembly instructions, see [Application Note M541](#), "Bonding and Handling Procedures for Chip Diode Devices" at [www.macomtech.com](http://www.macomtech.com).

## Ordering Information

Part Number	Package
MA4AGSW1A	Waffle Pack

## Данный компонент на территории Российской Федерации

### Вы можете приобрести в компании MosChip.

Для оперативного оформления запроса Вам необходимо перейти по данной ссылке:

<http://moschip.ru/get-element>

Вы можете разместить у нас заказ для любого Вашего проекта, будь то серийное производство или разработка единичного прибора.

В нашем ассортименте представлены ведущие мировые производители активных и пассивных электронных компонентов.

Нашей специализацией является поставка электронной компонентной базы двойного назначения, продукции таких производителей как XILINX, Intel (ex.ALTERA), Vicor, Microchip, Texas Instruments, Analog Devices, Mini-Circuits, Amphenol, Glenair.

Сотрудничество с глобальными дистрибьюторами электронных компонентов, предоставляет возможность заказывать и получать с международных складов практически любой перечень компонентов в оптимальные для Вас сроки.

На всех этапах разработки и производства наши партнеры могут получить квалифицированную поддержку опытных инженеров.

Система менеджмента качества компании отвечает требованиям в соответствии с ГОСТ Р ИСО 9001, ГОСТ РВ 0015-002 и ЭС РД 009

### Офис по работе с юридическими лицами:

105318, г.Москва, ул.Щербаковская д.3, офис 1107, 1118, ДЦ «Щербаковский»

Телефон: +7 495 668-12-70 (многоканальный)

Факс: +7 495 668-12-70 (доб.304)

E-mail: [info@moschip.ru](mailto:info@moschip.ru)

Skype отдела продаж:

moschip.ru

moschip.ru\_4

moschip.ru\_6

moschip.ru\_9