

Product Specification

+/-800 ps/nm (40km) Gen2 Tunable XFP Optical Transceiver

FTLX6624MCC-xx

PRODUCT FEATURES

- Supports 8.5Gb/s to 11.35Gb/s
- -800 to +800 ps/nm Dispersion Tolerance
- Supports 50GHz ITU-based channel spacing (C-Band) with a wavelength locker
- Monolithic MZM Tunable TOSA
- Temperature range: -5°C to 70°C
- RoHS-6 Compliant (lead-free)
- Power dissipation <3.5W
- Built-in digital diagnostic functions
- High performance PIN Receiver
- Adjustable receiver threshold with option for automatic optimization through FEC feedback



APPLICATIONS

- DWDM 10Gb/s SONET/SDH
- DWDM 10Gb/s Ethernet & 10Gb/s Fibre Channel
- DWDM 10Gb/s SONET/SDH w/FEC
- DWDM 10Gb/s Ethernet and 10Gb/s Fibre Channel w/FEC

Finisar's FTLX6624MCC-xx Small Form Factor 10Gb/s (XFP) transceiver complies with the XFP Multi-Source Agreement (MSA) Specification¹. It supports amplified DWDM 10Gb/s SONET/SDH, 10 Gigabit Ethernet, and 10 Gigabit Fibre Channel applications over 40km of fiber without dispersion compensation. Digital diagnostics functions are available via a 2-wire serial interface, as specified in the XFP MSA. The optical transceiver is compliant per the RoHS Directive 2011/65/EU³. See Finisar Application Note AN-2038 for more details⁴.

PRODUCT SELECTION

**Standard Gen2 T-XFP:
FTLX6624MCC**

I. Pin Descriptions

Pin	Logic	Symbol	Name/Description	Ref.
1		GND	Module Ground	1
2		VEE5	Optional -5.2 Power Supply – Not used	
3	LVTTL-I	Mod-Desel	Module De-select; When held low allows the module to respond to 2-wire serial interface commands	
4	LVTTL-O	Interrupt	Interrupt (bar); Indicates presence of an important condition which can be read over the serial 2-wire interface	2
5	LVTTL-I	TX_DIS	Transmitter Disable; Transmitter laser source turned off	
6		VCC5	+5 Power Supply	
7		GND	Module Ground	1
8		VCC3	+3.3V Power Supply	
9		VCC3	+3.3V Power Supply	
10	LVTTL-I	SCL	Serial 2-wire interface clock	2
11	LVTTL-I/O	SDA	Serial 2-wire interface data line	2
12	LVTTL-O	Mod_Abs	Module Absent; Indicates module is not present. Grounded in the module.	2
13	LVTTL-O	Mod_NR	Module Not Ready; Finisar defines it as a logical OR between RX_LOS and Loss of Lock in TX/RX.	2
14	LVTTL-O	RX_LOS	Receiver Loss of Signal indicator	2
15		GND	Module Ground	1
16		GND	Module Ground	1
17	CML-O	RD-	Receiver inverted data output	
18	CML-O	RD+	Receiver non-inverted data output	
19		GND	Module Ground	1
20		VCC2	+1.8V Power Supply – Not used	
21	LVTTL-I	P_Down/RST	Power Down; When high, places the module in the low power stand-by mode and on the falling edge of P_Down initiates a module reset	
			Reset; The falling edge initiates a complete reset of the module including the 2-wire serial interface, equivalent to a power cycle.	
22		VCC2	+1.8V Power Supply – Not used	
23		GND	Module Ground	1
24	PECL-I	RefCLK+	Not Required	
25	PECL-I	RefCLK-	Not Required	
26		GND	Module Ground	1
27		GND	Module Ground	1
28	CML-I	TD-	Transmitter inverted data input	
29	CML-I	TD+	Transmitter non-inverted data input	
30		GND	Module Ground	1

Notes:

1. Module circuit ground is isolated from module chassis ground within the module.
2. Open collector; should be pulled up with 4.7k – 10kohms on host board to a voltage between 3.15V and 3.6V.

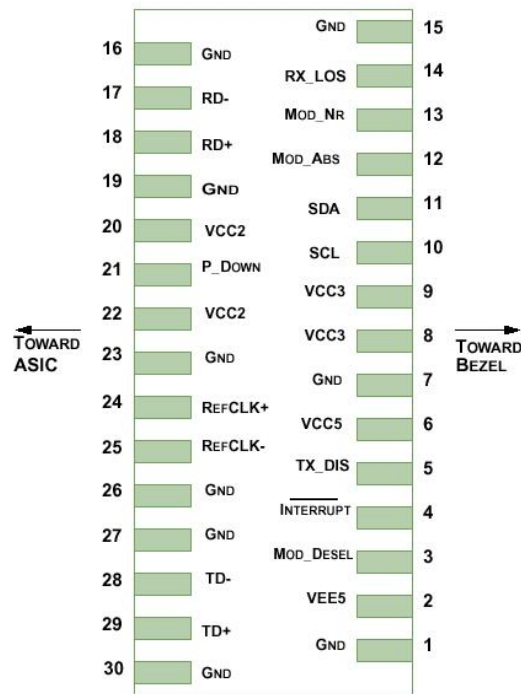

Diagram of Host Board Connector Block Pin Numbers and Names

II. Absolute Maximum Ratings

Parameter	Symbol	Min	Typ	Max	Unit	Ref.
Maximum Supply Voltage #1	Vcc3	-0.5		4.0	V	
Maximum Supply Voltage #2	Vcc5	-0.5		6.0	V	
Storage Temperature	T _S	-40		85	°C	
Case Operating Temperature	T _{OP}	-5		70	°C	
Receiver Damage Threshold	P _{Rdmg}	+3			dBm	

III. Electrical Characteristics (T_{OP} = -5 to 70 °C, V_{CC5} = 4.75 to 5.25 Volts)

FLTX6624MCC							
Parameter	Symbol	Min	Typ	Max	Unit	Ref.	
Supply Voltage #1	V _{CC3}	3.13		3.46	V		
Supply Voltage #2	V _{CC5}	4.75		5.25	V		
Supply Current – V _{CC5} supply	I _{CC5}			500	mA		
Supply Current – V _{CC3} supply	I _{CC3}			750	mA		
Module total power dissipation	P			3.5	W	1	
Transmitter							
Input differential impedance	R _{in}		100		Ω	2	
Differential data input swing	V _{in,pp}	120		820	mV		
Transmit Disable Voltage	V _D	2.0		V _{CC}	V	3	
Transmit Enable Voltage	V _{EN}	GND		GND+ 0.8	V		
Receiver							
Differential data output swing	V _{out,pp}		500	850	mV	4	
Data output rise time	t _r			40	ps	5	
Data output fall time	t _f			40	ps	5	
LOS Fault	V _{LOS fault}	V _{CC} – 0.5		V _{CCHOST}	V	6	
LOS Normal	V _{LOS norm}	GND		GND+0.5	V	6	
Power Supply Rejection	PSR	See Note 7 below					7
Reference Clock (AC-Coupled)							
Single-ended peak to peak voltage swing	V _{SEPP}	200		900	mV		
Single-ended resistance	R _L	40	50	60			
Frequency clock tolerance	Δf	-100		+100	ppm		
Duty cycle	-	40		60	%		

Notes:

1. Maximum total power value is specified across the full temperature and voltage range.
2. After internal AC coupling.
3. Or open circuit.
4. Into 100 ohms differential termination.
5. 20 – 80 %
6. Loss Of Signal is open collector to be pulled up with a 4.7k – 10kohm resistor to 3.15 – 3.6V. Logic 0 indicates normal operation; logic 1 indicates no signal detected.
7. Per Section 2.7.1. in the XFP MSA Specification¹.

IV. Optical Characteristics (EOL, $T_{OP} = -5$ to 70°C , $V_{CC5} = 4.75$ to 5.25 Volts)

Transmitter		FLTX6624MCC				
Parameter	Symbol	Min	Typ	Max	Unit	Ref
Output Opt. Pwr: 9/125 SMF	P_{OUT}	-1		+3.0	dBm	
Optical Extinction Ratio	ER	10	11		dB	
Wavelength range (ITU Grid)	λ	1528.77		1563.86	nm	
Crossing Ratio		40		60	%	
Center Wavelength Spacing			50		GHz	1
Transmitter Center Wavelength – End Of Life	λ_c	$\lambda_c - 2.5$	λ_c	$\lambda_c + 2.5$	GHz	2
Side Mode Suppression Ratio	SMSR	35			dB	
Wavelength tuning (Cold Start)				30	s	
Wavelength tuning (Warm)			0.5	2	s	
Tx Jitter (SONET) 20kHz-80MHz	T_{Xj1}			0.3	UI	3
Tx Jitter (SONET) 4MHz – 80MHz	T_{Xj2}			0.1	UI	4
Relative Intensity Noise	RIN			-135	dB/Hz	
SBS threshold (1% of launch power reflected) – Dither On		+16			dBm	
Receiver						
Overload	P_{MAX}	-1			dBm	
Optical Center Wavelength	λ_C	1270		1615	nm	
Receiver Reflectance	R_{rx}			-27	dB	
LOS De-Assert	LOS_D			-16	dBm	
LOS Assert	LOS_A	-26			dBm	
LOS Hysteresis		0.5			dB	

FTLX6624MCC					
Receiver Sensitivity ⁵					
Data rate (Gb/s)	BER	Dispersion (ps/nm)	Sensitivity back-to-back at OSNR>30dB (dBm)	Dispersion Penalty at OSNR>30dB (dB)	Threshold Adjust Required
9.95	1e-12	-800 to +800	-17	2	No
10.3	1e-12	-800 to +800	-17	2	No
10.7	1e-4	-800 to +800	-21	2.5	Yes
11.1	1e-4	-800 to +800	-21	3	Yes
11.3	1e-4	-800 to +800	-20	3	Yes
OSNR Performance ⁶					
Data rate (Gb/s)	BER	Dispersion (ps/nm)	Min OSNR Back-to-back at Power: -14 to -2dBm (dB)	Max OSNR Penalty at Power: -14 to -2dBm (dB)	Threshold Adjust Required
9.95	1e-12	-800 to +800	24	3	No
10.3	1e-12	-800 to +800	24	3	No
10.7	1e-4	-800 to +800	14.5	3	Yes
11.1	1e-4	-800 to +800	14.5	3	Yes
11.3	1e-4	-800 to +800	15	3	Yes

Notes:

1. Corresponds to approximately 0.4 nm.
2. λc = Specified ITU Grid wavelength. Wavelength stability is achieved within 30 seconds of power up.
3. Measured with a host jitter of 50 mUI peak-to-peak.
4. Measured with a host jitter of 7 mUI RMS.
5. Measured at 1528-1600nm with worst ER; PRBS31.
6. All OSNR measurements are performed with 0.1nm resolution.

V. Additional Specifications and Response Timing

Parameter	Symbol	Min	Typ	Max	Units	Ref.
Bit Rate	BR	8.5		11.35	Gb/s	1
Maximum Supported Link Length	L _{MAX}		40		km	2
PMD Penalty (30ps of DGD)				1	dB	

Notes:

1. Amplified SONET OC-192, 10G Ethernet, SONET OC-192 with FEC, 10G Ethernet with FEC, 10G Fibre Channel with FEC.
2. Distance indicates dispersion budget. Optical amplification may be required to achieve maximum distance.

Transmitter Power Monitor Accuracy

Initial accuracy at 25C: +/- 1.5dB.
 Relative accuracy over temperature, voltage and aging: +/- 2dB.

Received Optical Power Monitor Accuracy (applicable measurement range defined from -17dBm to -1dBm)

Initial accuracy at 25C: +/- 1.5dB.
 Relative accuracy over temperature, voltage and aging: +/- 2dB.
 Response timing:

Parameter		Min	Typ	Max	Units	Ref.
Tx_Dis	Assert			10	us	
	De-assert			2	ms	
Rx_LOS	Asset			100	us	
	De-assert			100	us	
Mod_NR	Asset			1	ms	
	De-assert			1	ms	
Interrupt	Asset			200	ms	
	De-assert			500	us	
P_Down/RST Time		10			us	
P_Down/RST Asser Delay				100	us	
Start-up time (Initialize time)				300	ms	1

1. Time required for transponder to be ready to begin I2C communication with host from a cold start or a hardware reset condition.

VI. Environmental Specifications

Finisar FTLX6624MCC XFP transceivers have an operating temperature range from -5°C to +70°C case temperature.

Parameter	Symbol	Min	Typ	Max	Units	Ref.
Case Operating Temperature	T _{op}	-5		70	°C	
Storage Temperature	T _{sto}	-40		85	°C	

VII. Regulatory Compliance

Finisar Tunable XFP transceivers are Class 1 Laser Products. They are certified per the following standards:

Feature	Agency	Standard	Certificate Number
Laser Eye Safety	FDA/CDRH	CDRH 21 CFR 1040 and Laser Notice 50	9210176
Laser Eye Safety	TÜV	EN 60825-1: 1994+A11:1996+A2:2001 IEC 60825-1: 1993+A1:1997+A2:2001 IEC 60825-2: 2000, Edition 2	R72101686
Electrical Safety	TÜV	EN 60950	R72101686
Electrical Safety	UL/CSA	CLASS 3862.07 CLASS 3862.87	2283290 (LR 115314)

Copies of the referenced certificates are available at Finisar Corporation upon request.

VIII. Digital Diagnostics Functions

As defined by the XFP MSA¹, Finisar XFP transceivers provide digital diagnostic functions via a 2-wire serial interface, which allows real-time access to the following operating parameters:

- Transceiver temperature
- Laser bias current
- Transmitted optical power
- Received optical power
- Transceiver supply voltage
- TEC Temperature

It also provides a sophisticated system of alarm and warning flags, which may be used to alert end-users when particular operating parameters are outside of a factory-set normal range.

The operating and diagnostics information is monitored and reported by a Digital Diagnostics Transceiver Controller (DDTC) inside the transceiver, which is accessed through the 2-wire serial interface. When the serial protocol is activated, the serial clock signal (SCL pin) is generated by the host. The positive edge clocks data into the XFP transceiver into those segments of its memory map that are not write-protected. The negative edge clocks data from the XFP transceiver. The serial data signal (SDA pin) is bi-directional for serial data transfer. The host uses SDA in conjunction with SCL to mark the start and end of serial protocol activation. The memories are organized as a series of 8-bit data words that can be addressed individually or sequentially. The 2-wire serial interface provides sequential or random access to the 8 bit parameters, addressed from 000h to the maximum address of the memory.

For more detailed information, including memory map definitions, please see the XFP MSA documentation¹.

Receiver Threshold Adjustment

The FTLX6624MCC also provide access to receiver decision threshold adjustment via 2-wire serial interface, in order to improve receiver OSNR performance based on specific link conditions. It is implemented as follows:

- Rx Threshold of XFP transceivers will be factory-set for optimized performance in non-FEC applications. This will be the default value during both cold start (power-up) and warm start (module reset).
- The transceiver supports adjustment of Rx Threshold value by the host through register 76d, table 01h. This is intended to be used in FEC applications.

- Register 76d, table 01h is a volatile memory. Therefore if the transceiver is power-cycled, the register starts up with a value of 00h which corresponds to the default Rx Threshold value.
- The threshold adjustment input value is 2's complement 7 bit value (-128 to +127), with 0 corresponding to default Rx threshold value. Full range of adjustment provides at least a $\pm 10\%$ change in Rx threshold from the default value.
- An increase in RxDTV value sets the threshold closer to the "1" value of the eye. The Default setting is the factory tuned optimized set point and is not necessarily the 50% RxDTV value.

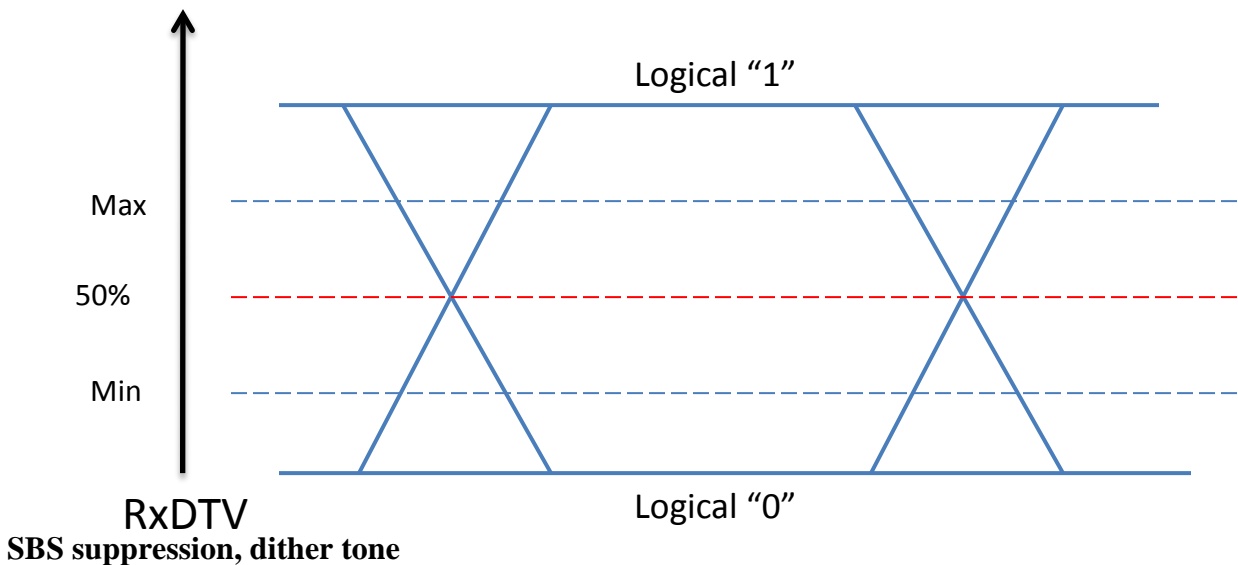

Set Address 111, bit 1 to "0" to enable tone, "1" to disable dither tone (defaults: frequency = 40kHz , tone is disabled). Please contact your Finisar RSM or PLM if specific amplitudes and frequencies are needed for SBS suppression.

Tuning Management Interface for ITU Frequency Grid Applications

Implementation of wavelength or frequency tunability is indicated in Serial ID Byte 221 (Table 01h) bit 1.

Data Address	Bit	Description
221 (Table 01h)	1	Wavelength or frequency tunability implemented

The Finisar tunable XFP supports both wavelength and frequency tuning (as specified in INF-8077i), the wavelength tuning support is indicated by the transceiver description encoded in Serial ID Byte 138 bits 2 and 3.

Address	Bit	Description of transceiver
138	3	Tunable DWDM (selection by channel number, bytes 112-113)
138	2	Tunable DWDM (selection in 50 pm steps, bytes 72-73)

138	1-0	Reserved
-----	-----	----------

Upon a power up, the module will go to a default wavelength (Finisar default channel is 1549.716nm) or the last channel set by the host. If Tx_DIS is asserted upon power up, the laser will be disabled and the set wavelength will be cleared. Once the Tx_DIS is de-asserted, the firmware will maintain the laser in an off state until the host sets the desired ITU channel. If the module is powered-down before the ITU channel was set and TX_DIS de-asserted, the module will re-start at the default channel. See the following startup channel flowchart.

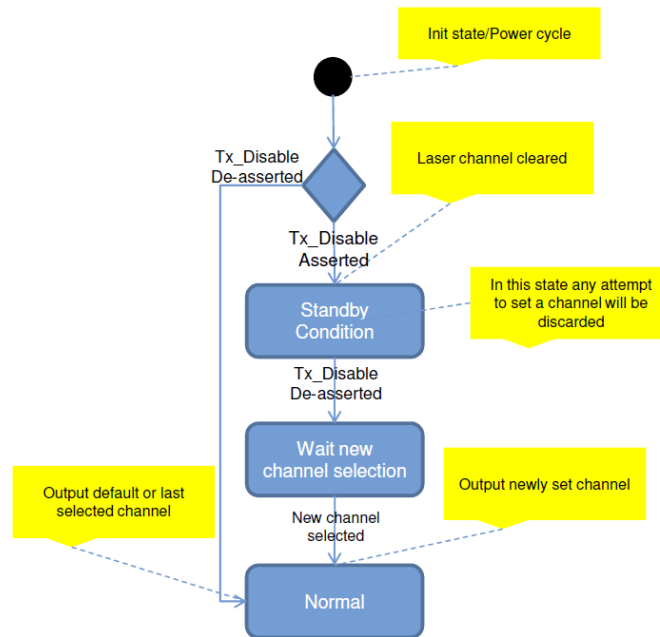

Flow Chart of Startup Channel

A desired wavelength can be commanded by the user by writing into Bytes 72 (MSB) and 73 (LSB). Wavelength control command:

Address	Bit	Name	Description
72 (MSB) & 73 (LSB)	All	Wavelength Set	User input of Wavelength set point (in units of 50 pm)
74 (MSB) & 75 (LSB)	All	Wavelength Error	Monitor of Current Wavelength Error (in units of 5 pm)

Thus for instance a target wavelength of 1556.55 nm would correspond to 79h (MSB) written to Byte address 72 and 9Bh (LSB) written to Byte address 73. Alternatively a desired frequency channel can be commanded by the user by writing into Bytes 112 (MSB) and 113 (LSB).

Address	Bit	Name	Description
112 (MSB) & 113 (LSB)	All	Channel Number Set	User input of channel number, which is an integer 1 to N (N=Number of Channels)
114 (MSB) & 115 (LSB)	All	Frequency Error	Frequency error reported in 16 bit signed integer with LSB=0.1 GHz
116-117	All	Reserved	Reserved

The channel number is derived from the following equation using parameters found in Module capabilities as listed in Byte Addresses 60-69:

$$\text{Channel number} = 1 + (\text{Desired Frequency} - \text{First Frequency}) / \text{Grid Spacing}$$

Alarm and Warning Threshold Values

Address	Parameter	Threshold Values	UNITS
02-03	Temp High Alarm	78	C
04-05	Temp Low Alarm	-13	C
06-07	Temp High Warning	73	C
08-09	Temp Low Warning	-8	C
10-17	Reserved		
18-19	Bias High Alarm	120	mA
20-21	Bias Low Alarm	5	mA
22-23	Bias High Warning	110	mA
24-25	Bias Low Warning	10	mA
26-27	TX Power High Alarm	+5	dBm
28-29	TX Power Low Alarm	-3	dBm
30-31	TX Power High Warning	+4	dBm
32-33	TX Power Low Warning	-2	dBm
34-35	RX Power High Alarm	+1	dBm
36-37	RX Power Low Alarm	-20	dBm
38-39	RX Power High Warning	0	dBm
40-41	RX Power Low Warning	-18	dBm
42-43	AUX 1 High Alarm	57	C
44-45	AUX 1 Low Alarm	20	C
46-47	AUX 1 High Warning	54	C
48-49	AUX 1 Low Warning	25	C
50-51	AUX 2 High Alarm	3.564	V
52-53	AUX 2 Low Alarm	3.036	V
54-55	AUX 2 High Warning	3.465	V
56-57	AUX 2 Low Warning	3.135	V

A/D Table

Address	Parameter	Accuracy	Resolution	Notes
96-97	Module Case Temp	+/-3degC	+/- 0.1degC	PCB mounted thermocouple
98-99	Reserved			
100-101	TX bias current	+/-8uA	+/-2uA	
102-103	Transmit Power	+/-1.5 dB	0.1uW	
104-105	Receive Power	+/-1.5 dB	+/-0.1uW	
106-107	Auxiliary monitor1	+/-3%	+/-0.1degC	Laser Temperature
108-109	Auxiliary monitor2	+/-3%	+/-100uV	3.3V Supply Voltage

IX. Mechanical Specifications

Finisar’s XFP transceivers are compliant with the dimensions defined by the XFP Multi-Sourcing Agreement (MSA).

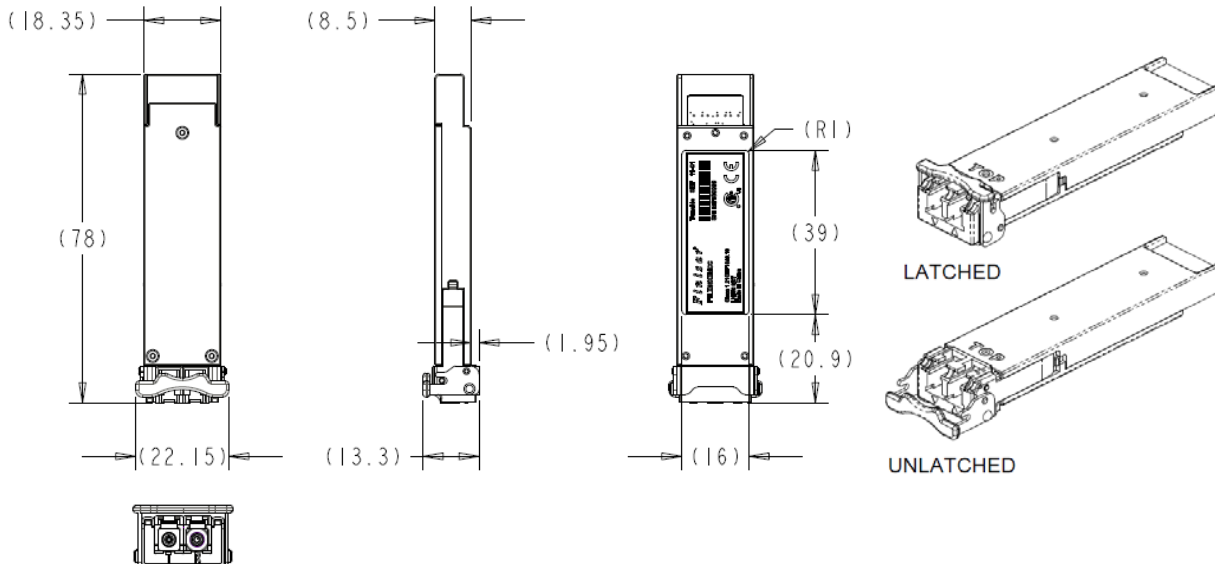

XFP Transceiver (dimensions are in mm)

X. PCB Layout and Bezel Recommendations

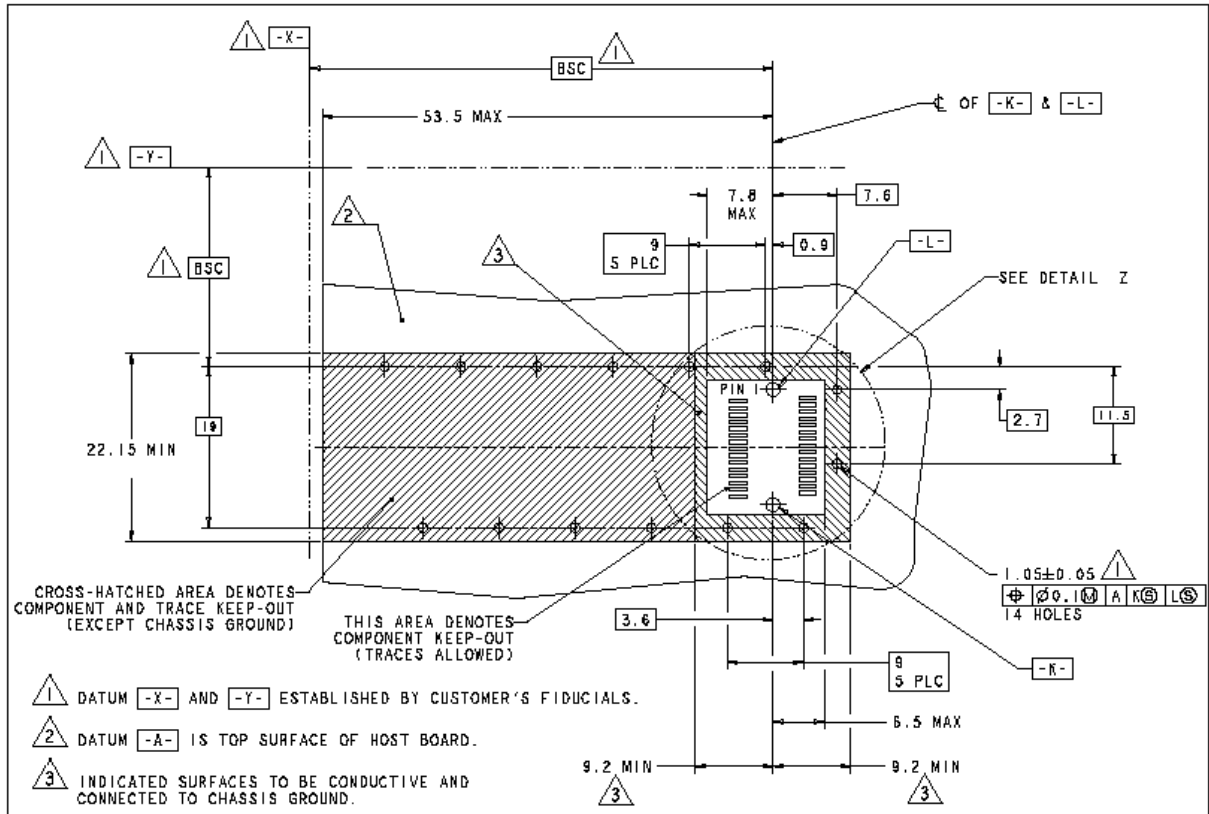

XFP Host Board Mechanical Layout (dimensions are in mm)

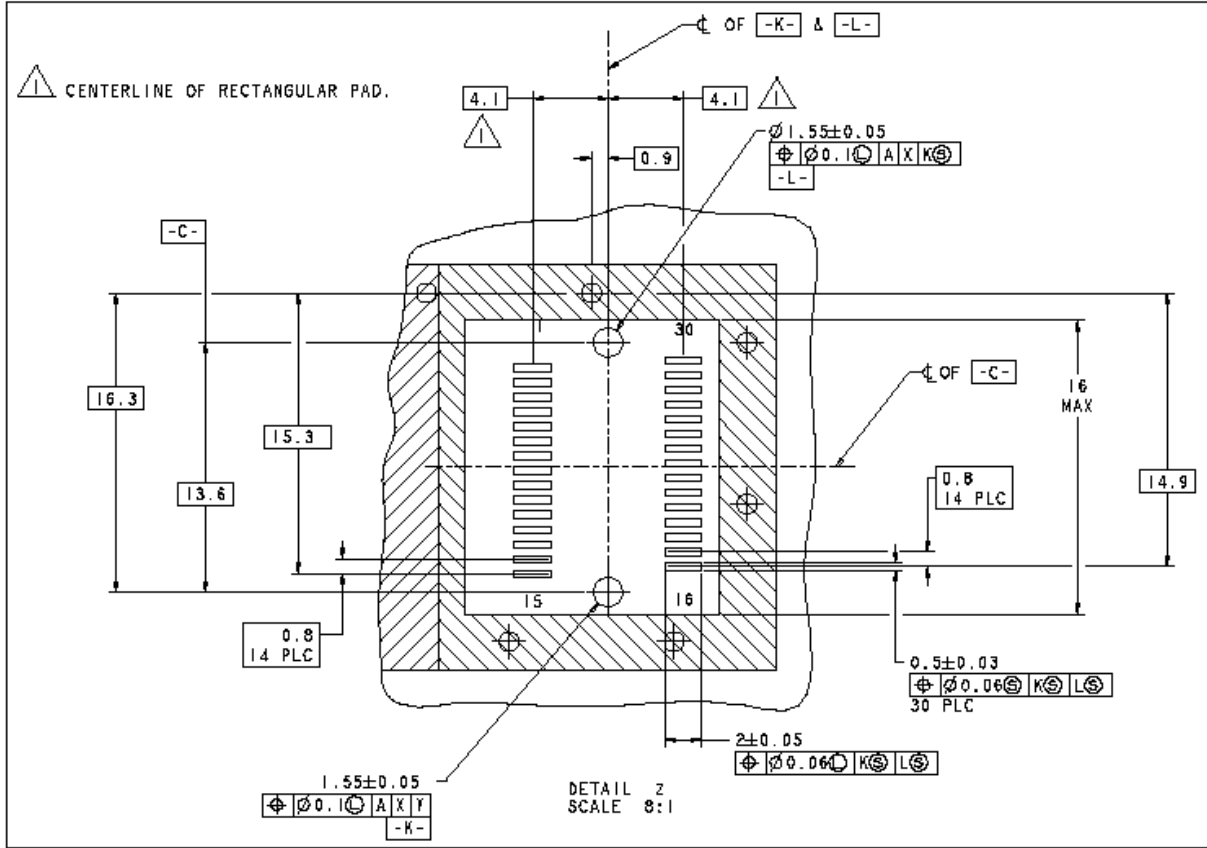

XFP Detail Host Board Mechanical Layout (dimensions are in mm)

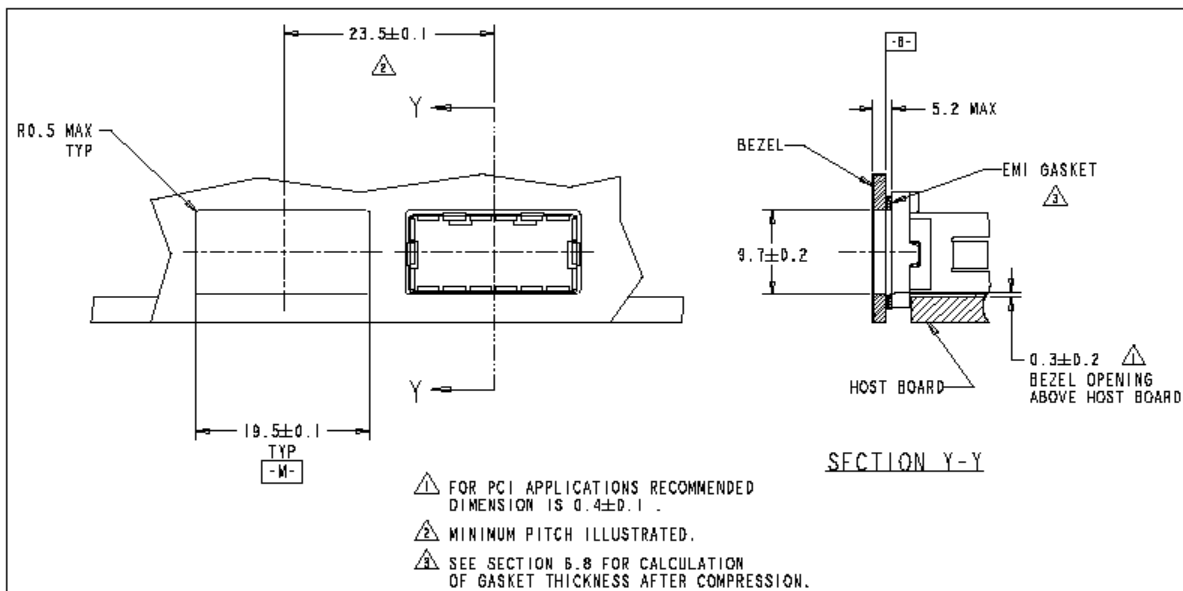

XFP Recommended Bezel Design (dimensions are in mm)

XI. Notes & Exceptions

- XFI loopback operation:
 - When XFI Loopback is enabled, the Transmitter output is disabled.
 - When Line Loopback is enabled, the CDR output is disabled.
- 8.5Gb/s operation requires configuration change via I2C vendor reserved command.

XII. References

1. 10 Gigabit Small Form Factor Pluggable Module (XFP) Multi-Source Agreement (MSA), Rev 4.5 – August 2005 (or later). Documentation is currently available at <http://www.xfpmsa.org/>
2. Application Note AN-2035: “Digital Diagnostic Monitoring Interface for XFP Optical Transceivers” – Finisar Corporation, December 2003
3. Directive 2011/65/EU of the European Council Parliament and of the Council, “on the restriction of the use of certain hazardous substances in electrical and electronic equipment”. Certain products may use one or more exemptions as allowed by the Directive.
4. “Application Note AN-2038: Finisar Implementation of RoHS Compliant Transceivers”.
5. SFF-8477 Revision 1.4: “Specification for Tunable XFP for ITU Frequency Grid Applications”. December 4, 2009 (or later). Documentation is currently available at <ftp://ftp.seagate.com/sff>

XIII. Product Selection Details

FTLX6624MCC-xx

FT: FT Series

L: RoHS-6

X: 10G Bit Rate Class

66: 40km (0 chirp) widely tunable with PIN Receiver

2: Gen2 T-XFP

4: 4 High-Performance

M: Multiprotocol, 8.5 Gb/s supported with I2C command

C: Commercial temperature range

C: ITU-T C-Band 50GHz spacing

xx: customer specific (not required for standard configuration)

XIV. Revision History

Revision	Date	Description
A00	Oct 2014	Initial Release
A01	June 2015	Updated Rx Power Alarm Lowsetting; updated units in A/D table
B1	August 2015	Updated logo and RoHS statement

XV. For More Information

Finisar Corporation
1389 Moffett Park Drive
Sunnyvale, CA 94089-1133
Tel. 1-408-548-1000
Fax 1-408-541-6138
sales@finisar.com
www.finisar.com

Данный компонент на территории Российской Федерации

Вы можете приобрести в компании MosChip.

Для оперативного оформления запроса Вам необходимо перейти по данной ссылке:

<http://moschip.ru/get-element>

Вы можете разместить у нас заказ для любого Вашего проекта, будь то серийное производство или разработка единичного прибора.

В нашем ассортименте представлены ведущие мировые производители активных и пассивных электронных компонентов.

Нашей специализацией является поставка электронной компонентной базы двойного назначения, продукции таких производителей как XILINX, Intel (ex.ALTERA), Vicor, Microchip, Texas Instruments, Analog Devices, Mini-Circuits, Amphenol, Glenair.

Сотрудничество с глобальными дистрибьюторами электронных компонентов, предоставляет возможность заказывать и получать с международных складов практически любой перечень компонентов в оптимальные для Вас сроки.

На всех этапах разработки и производства наши партнеры могут получить квалифицированную поддержку опытных инженеров.

Система менеджмента качества компании отвечает требованиям в соответствии с ГОСТ Р ИСО 9001, ГОСТ РВ 0015-002 и ЭС РД 009

Офис по работе с юридическими лицами:

105318, г.Москва, ул.Щербаковская д.3, офис 1107, 1118, ДЦ «Щербаковский»

Телефон: +7 495 668-12-70 (многоканальный)

Факс: +7 495 668-12-70 (доб.304)

E-mail: info@moschip.ru

Skype отдела продаж:

moschip.ru

moschip.ru_4

moschip.ru_6

moschip.ru_9