

Datasheet Sensirion SCD30 Sensor Module

CO₂, humidity, and temperature sensor

- NDIR CO₂ sensor technology
- Integrated temperature and humidity sensor
- Best performance-to-price ratio
- Dual-channel detection for superior stability
- Small form factor: 35 mm x 23 mm x 7 mm
- Measurement range: 400 ppm – 10.000 ppm
- Accuracy: $\pm(30 \text{ ppm} + 3\%)$
- Current consumption: 19 mA @ 1 meas. per 2 s.
- Fully calibrated and linearized
- Digital interface UART or I²C



Product Summary

CMOSens® Technology for IR detection enables carbon dioxide measurements of the highest accuracy at a competitive price.

Along with the NDIR measurement technology for detecting CO₂ comes a best-in-class Sensirion humidity and temperature sensor integrated on the very same sensor module. Ambient humidity and temperature can be measured by Sensirion's algorithm expertise through modelling and compensating of external heat sources without the need of any additional components. The very small module height allows easy integration into different applications.

Carbon Dioxide is a key indicator for indoor air quality. Thanks to new energy standards and better insulation, houses have become increasingly energy-efficient, but the air quality can deteriorate rapidly. Active ventilation is needed to maintain a comfortable and healthy indoor environment and improve the well-being and productivity of the inhabitants. Sensirion sensor solutions offer an accurate and stable monitoring of CO₂ in the air, as well as temperature and humidity. This enables our customers to develop new solutions that increase energy efficiency and simultaneously support the well-being of everyone.

Content

1 Sensor Specifications	2
2 Package Outline Drawing	4
3 Pin-Out Diagram	5
4 Operation and Communication	5
5 Shipping Package	5
6 Ordering Information	5
7 Important Notices	6
8 Headquarters and Subsidiaries	7

1 Sensor Specifications¹

CO₂ Sensor Specifications

Parameter	Conditions	Value
CO ₂ measurement range	I2C, UART PWM	0 – 40'000 ppm 0 – 5'000 ppm
Accuracy ²	400 ppm – 10'000 ppm	± (30 ppm + 3%MV)
Repeatability ³	400 ppm – 10'000 ppm	± 10 ppm
Temperature stability ⁴	T = 0 ... 50°C	± 2.5 ppm / °C
Response time ⁵	$\tau_{63\%}$	20 s
Accuracy drift over lifetime ⁶	400 ppm – 10'000 ppm ASC field-calibration algorithm activated and SCD30 in environment allowing for ASC, or FRC field-calibration algorithm applied.	± 50 ppm

Table 1: SCD30 CO₂ sensor specifications

Humidity Sensor Specifications⁷

Parameter	Conditions	Value
Humidity measurement range	-	0 %RH – 100 %RH
Accuracy ⁸	25°C, 0 – 100 %RH	± 3 %RH
Repeatability ³	-	± 0.1 %RH
Response time ⁵	$\tau_{63\%}$	8 s
Accuracy drift	-	< 0.25 %RH / year

Table 2: SCD30 humidity sensor specifications

Temperature Sensor Specifications⁷

Parameter	Conditions	Value
Temperature measurement range ⁹	-	- 40°C – 70°C
Accuracy ⁸	0 – 50°C	± (0.4°C + 0.023 × (T [°C] – 25°C))
Repeatability ³	-	± 0.1°C
Response time ⁵	$\tau_{63\%}$	> 10 s
Accuracy drift	-	< 0.03 °C / year

Table 3: SCD30 temperature sensor specifications

¹ Default conditions of T = 25°C, humidity = 50 %RH, p = 1013 mbar, V_{DD} = 3.3 V, continuous measurement mode with measurement rate = 2 s apply to values listed in the tables, unless otherwise stated.

² Deviation to a high-precision reference in the calibrated range (400 – 10'000 ppm) of the SCD30. Accuracy is fulfilled by > 90% of the sensors after calibration. Rough handling, shipping and soldering reduces the accuracy of the sensor. Full accuracy is restored with FRC or ASC recalibration features. Accuracy is based on tests with gas mixtures having a tolerance of ± 1.5%.

³ RMS error of consecutive measurements at constant conditions. Repeatability is fulfilled by > 90% of the sensors.

⁴ Average slope of CO₂ accuracy when changing temperature, valid at 400 ppm. Fulfilled by > 90% of the sensors after calibration.

⁵ Time for achieving 63% of a respective step function. Response time depends on design-in, heat exchange and environment of the sensor in the final application.

⁶ CO₂ concentrations < 400 ppm may result in sensor drifts when ASC is activated. For proper function of ASC field-calibration algorithm SCD30 has to be exposed to air with CO₂ concentration 400 ppm regularly.

⁷ Design-in of the SCD30 in final application and the environment impacts the accuracy of the RH/T sensor. Heat sources have to be considered for optimal performance. Please use integrated on-board RH/T compensation algorithm to account for the actual design-in.

⁸ Deviation to a high-precision reference. Accuracy is fulfilled by > 90% of the sensors after calibration.

⁹ RH/T sensor component is capable of measuring up to T = 120°C. Measuring at T > 70°C might result in permanent damage of the sensor.

Electrical Specifications

Parameter	Conditions	Value
Average current ¹⁰	Update interval 2 s	19 mA
Max. current	During measurement	75 mA
DC supply voltage (V _{ddmin} - V _{ddmax})	Min. and max. criteria to operate SCD30	3.3 V – 5.5 V
Interface	-	UART (Modbus Point to Point), PWM and I ² C
Input high level voltage (V _{IH})	Min. and max. criteria to operate SCD30	1.75 V – 5.5 V
Input low level voltage (V _{IL})	Min. and max. criteria to operate SCD30	- 0.3 V – 0.9 V
Output low level voltage (V _{OL})	I _{IO} = +8 mA, Max. criteria	0.4 V
Output high level voltage (V _{OH})	I _{IO} = -6 mA, Min. criteria	2.4 V

Table 4 SCD30 electrical specifications

Operation Conditions, Lifetime and Maximum Ratings

Parameter	Conditions	Value
Temperature operating conditions	Valid for CO ₂ sensor.	0 – 50°C
Humidity operating conditions	Non-condensing. Valid for CO ₂ sensor.	0 – 95 %RH
DC supply voltage	Exceeding specified range will result in damage of the sensor.	- 0.3 V – 6.0V
Voltage to pull up selector-pin	Max criteria	4.0 V
Storage temperature conditions	Exceeding specified range will result in damage of the sensor.	- 40°C – 70°C
Maintenance Interval	Maintenance free when ASC field-calibration algorithm ¹¹ is used.	None
Sensor lifetime	-	15 years

Table 5: SCD30 operation conditions, lifetime and maximum ratings

¹⁰ Average current including idle state and processing. Other update rates for small power budgets can be selected via the digital interface.

¹¹ CO₂ concentrations < 400 ppm may result in sensor drifts. For proper function of ASC field-calibration algorithm SCD30 has to be exposed to air with 400 ppm regularly.

2 Package Outline Drawing

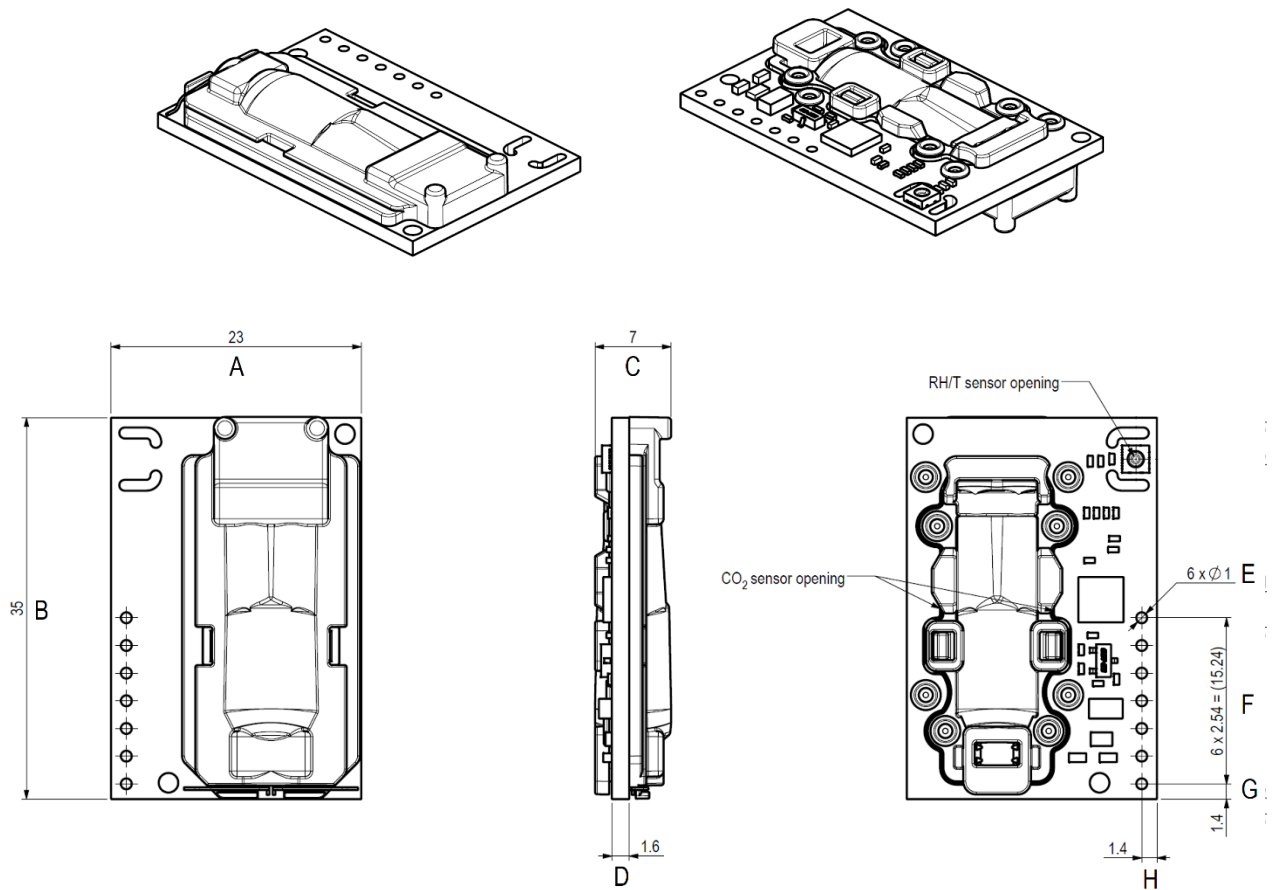

Figure 1 Product outline drawing of SCD30. Pictures on the left show top-view, pictures on the right bottom-view.

Sensor height is 7 mm at the thickest part of SCD30. The weight of one SCD30 sensor is 3.4 g.

Table 6: Nominal dimensions and tolerances SCD30

Dimension	A	B	C	D	E	F	G	H
Nominal [mm]	23.00	35.00	7.00	1.60	1.00	15.24	1.40	1.40
Tolerance [mm]	± 0.20	± 0.20	± 0.70	± 0.20	± 0.15	± 0.30	± 0.15	± 0.15

3 Pin-Out Diagram

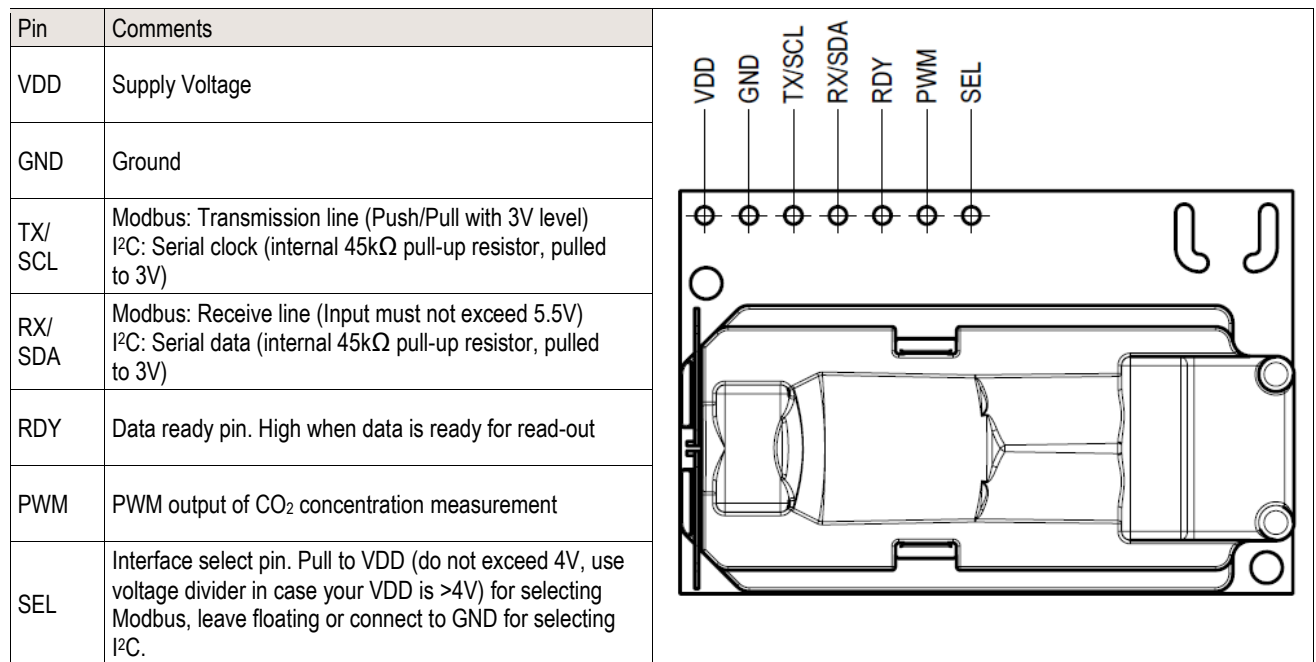

Figure 2: Pin-out of the SCD30.

4 Operation and Communication

Communication lines for I²C have an internal pull-up (45kΩ) to 3V. For communication voltages above 3V external pull-ups are required¹². Please visit the download center of Sensirion webpage for the I²C, Modbus and PWM interface documentation¹³.

5 Shipping Package

SCD30 sensor is shipped in stackable trays with 40 pieces each. The tray dimension is 363 mm x 257 mm x 19 mm. Stacking of trays results in an effective tray height of 13 mm.

6 Ordering Information

SCD30 and accessory can be ordered via the following article numbers.

Product	Description	Article Number
SCD30 sensor	CO ₂ , RH and T sensor module	1-101625-10
SEK-SCD30-Sensor	Standalone SCD30 sensor for EvalKit	3.000.061
SEK-SensorBridge	Sensor Bridge to connect SEK-SCD30-Sensor to computer	3.000.095

¹² Check VIH level of your I²C master to determine communication voltage

¹³ www.sensirion.com/file/scd30_interface_description

7 Important Notices

7.1 Warning, Personal Injury

Do not use this product as safety or emergency stop devices or in any other application where failure of the product could result in personal injury. Do not use this product for applications other than its intended and authorized use. Before installing, handling, using or servicing this product, please consult the data sheet and application notes. Failure to comply with these instructions could result in death or serious injury.

If the Buyer shall purchase or use SENSIRION products for any unintended or unauthorized application, Buyer shall defend, indemnify and hold harmless SENSIRION and its officers, employees, subsidiaries, affiliates and distributors against all claims, costs, damages and expenses, and reasonable attorney fees arising out of, directly or indirectly, any claim of personal injury or death associated with such unintended or unauthorized use, even if SENSIRION shall be allegedly negligent with respect to the design or the manufacture of the product.

7.2 ESD Precautions

The inherent design of this component causes it to be sensitive to electrostatic discharge (ESD). To prevent ESD-induced damage and/or degradation, take customary and statutory ESD precautions when handling this product. See application note "ESD, Latchup and EMC" for more information.

7.3 Warranty

SENSIRION warrants solely to the original purchaser of this product for a period of 12 months (one year) from the date of delivery that this product shall be of the quality, material and workmanship defined in SENSIRION's published specifications of the product. Within such period, if proven to be defective, SENSIRION shall repair and/or replace this product, in SENSIRION's discretion, free of charge to the Buyer, provided that:

- notice in writing describing the defects shall be given to SENSIRION within fourteen (14) days after their appearance;
- such defects shall be found, to SENSIRION's reasonable satisfaction, to have arisen from SENSIRION's faulty design, material, or workmanship;
- the defective product shall be returned to SENSIRION's factory at the Buyer's expense; and
- the warranty period for any repaired or replaced product shall be limited to the unexpired portion of the original period.

This warranty does not apply to any equipment which has not been installed and used within the specifications recommended by SENSIRION for the intended and proper use of the equipment. EXCEPT FOR THE WARRANTIES EXPRESSLY SET FORTH HEREIN, SENSIRION MAKES NO WARRANTIES, EITHER EXPRESS OR IMPLIED, WITH RESPECT TO THE PRODUCT. ANY AND ALL WARRANTIES, INCLUDING WITHOUT LIMITATION, WARRANTIES OF MERCHANTABILITY OR FITNESS FOR A PARTICULAR PURPOSE, ARE EXPRESSLY EXCLUDED AND DECLINED.

SENSIRION is only liable for defects of this product arising under the conditions of operation provided for in the data sheet and proper use of the goods. SENSIRION explicitly disclaims all warranties, express or implied, for any period during which the goods are operated or stored not in accordance with the technical specifications.

SENSIRION does not assume any liability arising out of any application or use of any product or circuit and specifically disclaims any and all liability, including without limitation consequential or incidental damages. All operating parameters, including without limitation recommended parameters, must be validated for each customer's applications by customer's technical experts. Recommended parameters can and do vary in different applications.

SENSIRION reserves the right, without further notice, (i) to change the product specifications and/or the information in this document and (ii) to improve reliability, functions and design of this product.

Copyright© 2018, by SENSIRION.
CMOSens® is a trademark of Sensirion
All rights reserved

8 Headquarters and Subsidiaries

Sensirion AG

Laubisruestr. 50
CH-8712 Staefa ZH
Switzerland

phone: +41 44 306 40 00

fax: +41 44 306 40 30

info@sensirion.com

www.sensirion.com

Sensirion Taiwan Co. Ltd

phone: +886 3 5506701

info@sensirion.com

www.sensirion.com

Sensirion Inc., USA

phone: +1 312 690 5858

info-us@sensirion.com

www.sensirion.com

Sensirion Japan Co. Ltd.

phone: +81 3 3444 4940

info-jp@sensirion.com

www.sensirion.co.jp

Sensirion Korea Co. Ltd.

phone: +82 31 337 7700~3

info-kr@sensirion.com

www.sensirion.co.kr

Sensirion China Co. Ltd.

phone: +86 755 8252 1501

info-cn@sensirion.com

www.sensirion.com.cn

To find your local representative, please visit www.sensirion.com/distributors

Данный компонент на территории Российской Федерации

Вы можете приобрести в компании MosChip.

Для оперативного оформления запроса Вам необходимо перейти по данной ссылке:

<http://moschip.ru/get-element>

Вы можете разместить у нас заказ для любого Вашего проекта, будь то серийное производство или разработка единичного прибора.

В нашем ассортименте представлены ведущие мировые производители активных и пассивных электронных компонентов.

Нашей специализацией является поставка электронной компонентной базы двойного назначения, продукции таких производителей как XILINX, Intel (ex.ALTERA), Vicor, Microchip, Texas Instruments, Analog Devices, Mini-Circuits, Amphenol, Glenair.

Сотрудничество с глобальными дистрибьюторами электронных компонентов, предоставляет возможность заказывать и получать с международных складов практически любой перечень компонентов в оптимальные для Вас сроки.

На всех этапах разработки и производства наши партнеры могут получить квалифицированную поддержку опытных инженеров.

Система менеджмента качества компании отвечает требованиям в соответствии с ГОСТ Р ИСО 9001, ГОСТ РВ 0015-002 и ЭС РД 009

Офис по работе с юридическими лицами:

105318, г.Москва, ул.Щербаковская д.3, офис 1107, 1118, ДЦ «Щербаковский»

Телефон: +7 495 668-12-70 (многоканальный)

Факс: +7 495 668-12-70 (доб.304)

E-mail: info@moschip.ru

Skype отдела продаж:

moschip.ru

moschip.ru_4

moschip.ru_6

moschip.ru_9