

Main

Range of product	OsiSense XU
Series name	Application material handling
Electronic sensor type	Photo-electric sensor
Sensor name	XUV
Sensor design	Frame
Detection system	Thru beam
Emission	Infrared
Way dimensions of optical frame	200 x 180 mm
Material	Metal
Supply circuit type	DC
Wiring technique	4-wire
Discrete output type	PNP or NPN
Discrete output function	1 NO or 1 NC programmable
Electrical connection	M12 1 male connector, 4 pins
Product specific application	Dynamic detection of passage of objects Static detection of passage of objects
Minimum object diameter for detection	Dynamic mode: 0.16 in (4 mm) (0.33...49.21 ft/s) (0.1...15 m/s) Static mode: 0.24 in (6 mm)

Complementary

Enclosure material	Painted aluminium
Lens material	Altuglass
Type of output signal	Discrete
Output type	Solid state
Add on output	With alarm output
Status LED	1 LED (red) alarm 1 LED (amber) output state
[Us] rated supply voltage	24 V DC with reverse polarity protection
Supply voltage limits	18...30 V DC
Switching capacity in mA	<= 100 mA (overload and short-circuit protection)
Switching frequency	> 5000 Hz
Voltage drop	< 2 V (closed state)
Current consumption	<= 150 mA (no-load)
Time delay range	0...5 s off-delay delay
Delay first up	<= 100 ms
Delay recovery	< 0.1 ms
Setting-up	Sensitivity adjustment with potentiometer
Depth	0.98 in (25 mm)
Height	9.06 in (230 mm)
Width	10.43 in (265 mm)
Product weight	2.65 lb(US) (1.2 kg)

Environment

product certifications	CE CULus
ambient air temperature for operation	32...140 °F (0...60 °C)
ambient air temperature for storage	-4...176 °F (-20...80 °C)
immunity to ambient light	<= 10000 lux with sunlight

The information provided in this documentation contains general descriptions and/or technical characteristics of the products contained herein. This documentation is not intended as a substitute for and is not to be used for determining suitability or reliability of these products for specific user applications. It is the duty of any such user or integrator to perform the appropriate and complete risk analysis, evaluation and testing of the products with respect to the relevant specific application or use thereof. Neither Schneider Electric Industries SAS nor any of its affiliates or subsidiaries shall be responsible or liable for misuse of the information contained herein.

	<= 3000 lux with incandescent light
vibration resistance	25 gn, amplitude = +/- 2 mm (f = 10...55 Hz) conforming to IEC 60068-2-6
shock resistance	30 gn (duration = 11 ms) conforming to IEC 60068-2-27
IP degree of protection	IP65 conforming to IEC 60529

Offer Sustainability

Not Green Premium product	Not Green Premium product
Compliant - since 0724 - Schneider Electric declaration of conformity	Compliant - since 0724 - Schneider Electric declaration of conformity
WARNING: This product can expose you to chemicals including:	WARNING: This product can expose you to chemicals including:
Diisononyl phthalate (DINP), which is known to the State of California to cause cancer, and	Diisononyl phthalate (DINP), which is known to the State of California to cause cancer, and
Di-isodecyl phthalate (DIDP), which is known to the State of California to cause birth defects or other reproductive harm.	Di-isodecyl phthalate (DIDP), which is known to the State of California to cause birth defects or other reproductive harm.
For more information go to www.p65warnings.ca.gov	For more information go to www.p65warnings.ca.gov

Contractual warranty

Warranty period	18 months
-----------------	-----------

Dimensions

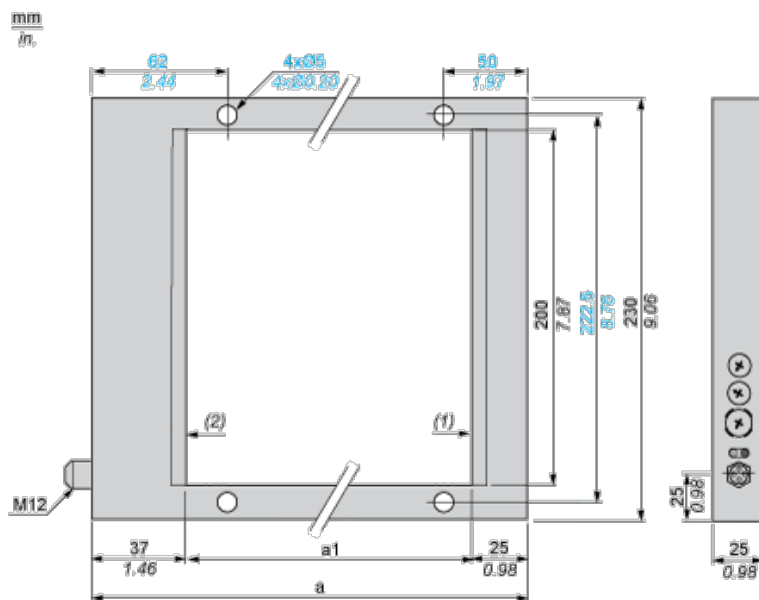

(1) Transmitting face

(2) Reception face

Dimensions in mm

a	a1
242	180

Dimensions in in.

a	a1
9.53	7.09

Wiring Schemes (4-Wire DC)

PNP Output

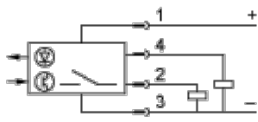

NPN Output

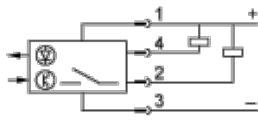

Connector Scheme

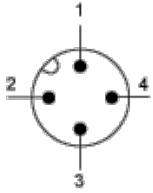

- 1 : +
- 2 : Not connected
- 3 : -
- 4 : Output

Данный компонент на территории Российской Федерации

Вы можете приобрести в компании MosChip.

Для оперативного оформления запроса Вам необходимо перейти по данной ссылке:

<http://moschip.ru/get-element>

Вы можете разместить у нас заказ для любого Вашего проекта, будь то серийное производство или разработка единичного прибора.

В нашем ассортименте представлены ведущие мировые производители активных и пассивных электронных компонентов.

Нашей специализацией является поставка электронной компонентной базы двойного назначения, продукции таких производителей как XILINX, Intel (ex.ALTERA), Vicor, Microchip, Texas Instruments, Analog Devices, Mini-Circuits, Amphenol, Glenair.

Сотрудничество с глобальными дистрибьюторами электронных компонентов, предоставляет возможность заказывать и получать с международных складов практически любой перечень компонентов в оптимальные для Вас сроки.

На всех этапах разработки и производства наши партнеры могут получить квалифицированную поддержку опытных инженеров.

Система менеджмента качества компании отвечает требованиям в соответствии с ГОСТ Р ИСО 9001, ГОСТ РВ 0015-002 и ЭС РД 009

Офис по работе с юридическими лицами:

105318, г.Москва, ул.Щербаковская д.3, офис 1107, 1118, ДЦ «Щербаковский»

Телефон: +7 495 668-12-70 (многоканальный)

Факс: +7 495 668-12-70 (доб.304)

E-mail: info@moschip.ru

Skype отдела продаж:

moschip.ru

moschip.ru_4

moschip.ru_6

moschip.ru_9