

Surge Protection Made Simple™ for Ethernet Data Cables

UL Listed 497B Universal DIN-Rail Mount Surge Protective Device for RJ45/Ethernet Cable Systems



Description

The Cooper Bussmann DIN-Rail mount BSPD48RJ45 Surge Protective Device (SPD) for Ethernet cable systems with RJ connectors is easy to install in new, or retrofitting into existing, installations.

The BSPD48RJ45 is installed between the patch panel and the active component (a switch for example). The snap-in mechanism of the supporting foot allows the SPD to be safely grounded via the DIN-Rail. For single applications, the BSPD48RJ45 comes with a supplied mounting bracket with cable lug.

Fulfilling the requirements of Category 6, the BSPD48RJ45 can be universally used for all data services up to nominal voltages of 48V. It is well suited for existing services such as Gigabit Ethernet, ATM, ISDN, Voice over IP and Power over Ethernet (PoE+ acc. to IEEE 802.3at up to 57V) and similar applications in structured cabling systems according to Class E up to 250MHz. Protection of all pairs by means of powerful gas discharge tubes and one adapter filter matrix per pair.

- UL 497B Listed
- Easy to install or retrofit for protection of all lines
- CAT 6 according to ISO/IEC 11801
- CAT 6 in the channel (Class E)
- Power over Ethernet (PoE+ according to IEEE 802.3at)

Dimensions -mm

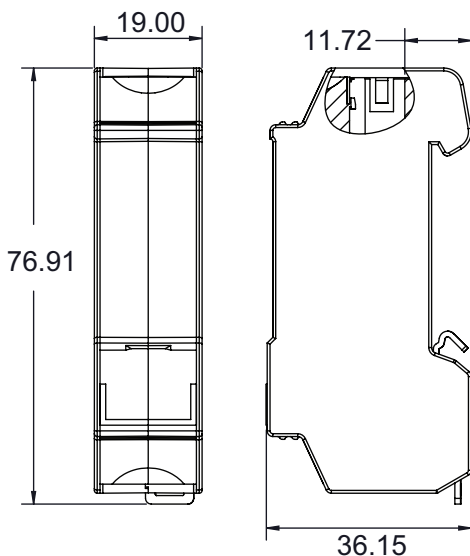

BSPD48RJ45



DIN-Rail Mount SPD for RJ45 / Ethernet Connection

Circuit Diagram

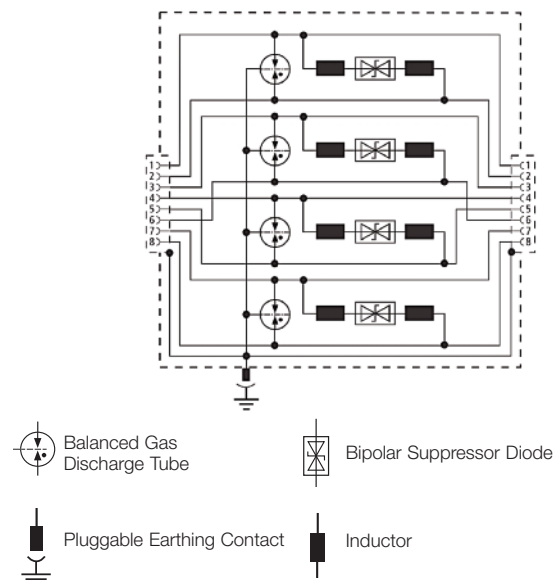

TECHNICAL DATA	
Catalog Number	BSPD48RJ45
Nominal voltage (U _N)	48V
Max. continuous operating DC voltage (U _C)	48V
Max. continuous operating AC voltage (U _C)	34V
Max. continuous DC voltage pair-pair (PoE) (U _C)	57V
Nominal current (I _N)	1A
C2 Nominal discharge current (8/20μs) line-line (I _n)	150A
C2 Nominal discharge current (8/20μs) line-PG (I _n)	2.5kA
C2 Total nominal discharge current (8/20μs) line-PG (I _n)	10kA
C2 nominal discharge current (8/20μs) pair-pair (PoE) (I _n)	150A
Voltage protection level line-line for I _n C2 (U _P)	≤190V
Voltage protection level line-PG for I _n C2 (U _P)	≤600V
Voltage protection level line-line for I _n C2 (PoE) (U _P)	≤600V
Voltage protection level line-line at 1kV/μs C3 (U _P)	≤180V
Voltage protection level line-PG at 1kV/μs C3 (U _P)	≤500V
Voltage protection level pair-pair at 1kV/μs C3 (PoE) (U _P)	≤600V
Insertion loss at 250MHz	≤3dB
Capacitance line-line (C)	≤30pF
Capacitance line-PG (C)	≤25pF
Operating temperature range	-40°C to +80°C
Degree of protection	IP10
For mounting on	35mm DIN-Rails per EN 60715
Connection (input / output)	RJ45 socket / RJ45 socket
Pinning	1 / 2, 3 / 6, 4 / 5, 7 / 8
Grounding	Via 35mm DIN-Rails per EN 60715
Enclosure material	Zinc die casting
Color	Bare surface
Test standards	IEC 61643-21 / EN 61643-21
Agency information	UL 497B
Warranty	5 Years*

* See Cooper Bussmann SPD Limited Warranty Statement (3A1502) for details at www.cooperbussmann.com/Surge.

DIN-Rail RJ45 SPDs Applications

Part Number	BSPD48RJ45
Bus systems and Measuring, and Control Technology	
Industrial Ethernet	X
Data Networks	
ATM	X
Ethernet 10/100/1000	X
FDDI, CDDI	X
Industrial Ethernet	X
Power over Ethernet (PoE)	X
Token Ring	X
VG Any LAN	X
Video Systems	
Video (2 wire)	X



The only controlled copy of this Data Sheet is the electronic read-only version located on the Cooper Bussmann Network Drive. All other copies of this document are by definition uncontrolled. This bulletin is intended to clearly present comprehensive product data and provide technical information that will help the end user with design applications. Cooper Bussmann reserves the right, without notice, to change design or construction of any products and to discontinue or limit distribution of any products. Cooper Bussmann also reserves the right to change or update, without notice, any technical information contained in this bulletin. Once a product has been selected, it should be tested by the user in all possible applications.

Данный компонент на территории Российской Федерации

Вы можете приобрести в компании MosChip.

Для оперативного оформления запроса Вам необходимо перейти по данной ссылке:

<http://moschip.ru/get-element>

Вы можете разместить у нас заказ для любого Вашего проекта, будь то серийное производство или разработка единичного прибора.

В нашем ассортименте представлены ведущие мировые производители активных и пассивных электронных компонентов.

Нашей специализацией является поставка электронной компонентной базы двойного назначения, продукции таких производителей как XILINX, Intel (ex.ALTERA), Vicor, Microchip, Texas Instruments, Analog Devices, Mini-Circuits, Amphenol, Glenair.

Сотрудничество с глобальными дистрибьюторами электронных компонентов, предоставляет возможность заказывать и получать с международных складов практически любой перечень компонентов в оптимальные для Вас сроки.

На всех этапах разработки и производства наши партнеры могут получить квалифицированную поддержку опытных инженеров.

Система менеджмента качества компании отвечает требованиям в соответствии с ГОСТ Р ИСО 9001, ГОСТ РВ 0015-002 и ЭС РД 009

Офис по работе с юридическими лицами:

105318, г.Москва, ул.Щербаковская д.3, офис 1107, 1118, ДЦ «Щербаковский»

Телефон: +7 495 668-12-70 (многоканальный)

Факс: +7 495 668-12-70 (доб.304)

E-mail: info@moschip.ru

Skype отдела продаж:

moschip.ru

moschip.ru_4

moschip.ru_6

moschip.ru_9