

DATA SHEET

SKY13489-001: 0.7 to 2.7 GHz SPDT High Power Switch (Single Bit Control) in a WLCSP Package

Applications

- LTE TDD/FDD transmit
- GSM transmit
- Embedded modules

Features

- Broadband frequency range: 0.7 to 2.7 GHz
- Low insertion loss: 0.3 dB @ 2.7 GHz
- High isolation: 22 dB up to 2.7 GHz
- No external DC blocking capacitors required
- Single GPIO control line with V_{DD} voltage regulator:
 - V_{CTL} = 1.35 to 3.00 V
 - V_{DD} = 2.45 to 4.80 V
- Small, 6-bump WLCSP, 217 μm diameter, 400 μm pitch (1.135 x 0.735 x 0.400 mm) package (MSL1, 260 °C per JEDEC J-STD-020)



Skyworks Green™ products are compliant with all applicable legislation and are halogen-free. For additional information, refer to *Skyworks Definition of Green™*, document number SQ04-0074.

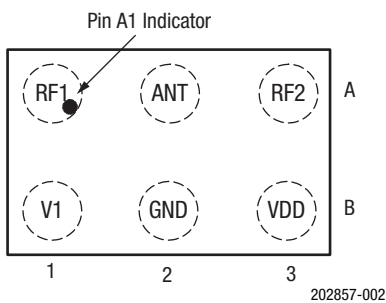

Figure 2. SKY13489-001 Pinout (Top View, Bumps Facing Down)

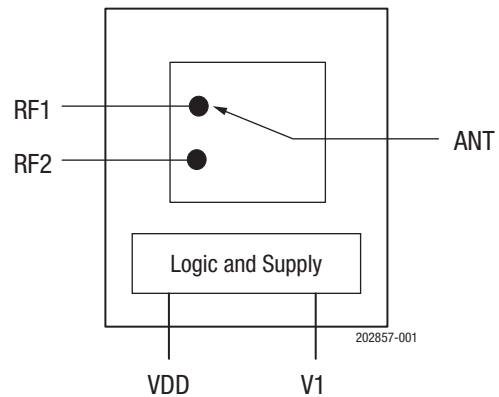

Figure 1. SKY13489-001 Block Diagram

Description

The SKY13489-001 is a single-pole, double-throw (SPDT) LTE/WCDMA/GSM transmit switch. Switching is controlled by an integrated GPIO interface with a single control pin. Depending on the logic voltage level applied to the control pin, the antenna port is connected to one of the switched RF outputs (RF1 or RF2) through a low insertion loss path, while the path between the antenna port and the other RF port is in a high isolation state.

No external DC blocking capacitors are required as long as no DC voltage is applied on any RF path.

The SKY13489-001 is provided in a compact 6-bump, 1.135 x 0.735 x 0.400 mm Wafer Level Chip Scale Package (WLCSP) that meets requirements for board-level assembly. Bump diameters are 217 microns with a minimum bump pitch of 400 microns.

A functional block diagram is shown in Figure 1. The pin configuration and package are shown in Figure 2. Signal pin assignments and functional pin descriptions are provided in Table 1.

Table 1. SKY13489-001 Signal Descriptions

Pin	Name	Description	Pin	Name	Description
A1	RF1	RF I/O. Throw 1 of the switch.	B1	V1	Digital control input
A2	ANT	Antenna	B2	GND	Ground
A3	RF2	RF I/O. Throw 2 of the switch.	B3	VDD	Supply voltage

Electrical and Mechanical Specifications

The absolute maximum ratings of the SKY13489-001 are provided in Table 2. Electrical specifications are provided in Tables 3 through 5.

The state of the SKY13489-001 is determined by the logic provided in Table 6.

Table 2. SKY13489-001 Absolute Maximum Ratings¹

Parameter	Symbol	Minimum	Maximum	Units
Supply voltage	VDD	2.4	5.0	V
Digital control voltage	VCTL	-0.2	+3.2	V
RF input power	PIN		+39	dBm
Operating temperature	TOP	-40	+90	°C
Storage temperature	TSTG	-55	+150	°C

¹ Exposure to maximum rating conditions for extended periods may reduce device reliability. There is no damage to device with only one parameter set at the limit and all other parameters set at or below their nominal value. Exceeding any of the limits listed here may result in permanent damage to the device.

ESD HANDLING: *Although this device is designed to be as robust as possible, electrostatic discharge (ESD) can damage this device. This device must be protected at all times from ESD when handling or transporting. Static charges may easily produce potentials of several kilovolts on the human body or equipment, which can discharge without detection. Industry-standard ESD handling precautions should be used at all times.*

Table 3. SKY13489-001 Electrical Specifications¹ (1 of 2)
(V_{DD} = 2.85 V, T_{OP} = +25 °C, Characteristic Impedance [Z₀] = 50 Ω, Unless Otherwise Noted)

Parameter	Symbol	Test Condition	Min	Typical	Max	Units
DC Specifications						
Supply voltage	V _{DD}		2.45	2.85	4.80	V
Control voltage: Low High	V1_L V1_H		-0.1 +1.35	0 +1.80	+0.45 +3.0	V V
Current on V1 pin	I _{CTL}				1	μA
Supply current	I _{DD}	V _{DD} = 2.65 V, V1 = V _{CTL_H}		30	45	μA
DC supply turn-on/turn-off time	t _{ON}	Measured from 50% of final V _{DD} supply voltage to 90% of final RF power			20	μs
RF path switching time	t _{SW}	From one active state to another active state transition, measured from 50% of final control voltage to 90% of final RF power		2	5	μs
Supply ripple	V _{PP}				20	mV _{pp}
RF Specifications						
Insertion loss (RF1 or RF2 to ANT pin)	IL	700 to 960 MHz 1710 to 2170 MHz 2170 to 2690 MHz		0.25 0.30 0.30	0.35 0.45 0.50	dB dB dB
Isolation (ANT to RF1 or RF2)	ISO	700 to 960 MHz 1710 to 2170 MHz 2170 to 2690 MHz	31 23 20	32 25 22		dB dB db
Voltage standing wave ratio, all ports	VSWR	Referenced to 50 Ω, 700 to 2690 MHz		1.1:1	1.2:1	
Compression point	P _{0.2dB}	700 to 2690 MHz	+37	+39		dBm
Large Signal Specifications						
Harmonic power, ANT to RF1 or RF2 (VSWR = 1:1)		fo = 824 to 915 MHz, P _{IN} = +35 dBm: 2fo 3fo fo = 1710 to 1910 MHz, P _{IN} = +33 dBm: 2fo 3fo fo = 824 to 960 MHz, P _{IN} = +25 dBm: 2fo 3fo fo = 1710 to 1910 MHz, P _{IN} = +25 dBm: 2fo 3fo fo = 1910 to 2690 MHz, P _{IN} = +25 dBm: 2fo 3fo		-65 -63 -74 -71 -82 -82 -80 -78 -68 -69	-60 -55 -68 -65 -78 -75 -75 -73	dBm dBm dBm dBm dBm dBm dBm dBm dBm dBm

Table 3. SKY13489-001 Electrical Specifications¹ (2 of 2)
(V_{DD} = 2.85 V, T_{OP} = +25 °C, Characteristic Impedance [Z₀] = 50 Ω, Unless Otherwise Noted)

Parameter	Symbol	Test Condition	Min	Typical	Max	Units
<i>Large Signal Specifications (continued)</i>						
Second order intermodulation distortion, ANT to RF1 or RF2	IMD2	CW carrier = +20 dBm, CW blocker = -15 dBm: Band 1 Band 5		-110 -120	-105 -110	dBm dBm
Third order intermodulation distortion, ANT to RF1 or RF2	IMD3	CW carrier = +20 dBm, CW blocker = -15 dBm: Band 1 Band 5		-120 -120	-110 -110	dBm dBm

¹ Performance is guaranteed only under the conditions listed in this table.

Table 4. Third Order Intermodulation Distortion Frequencies

IMD3 Band	f _{rx} (MHz)		f _{BLOCK 1} (MHz)		f _{BLOCK 2} (MHz)	f _{BLOCK 3} (MHz)	
	Minimum	Maximum	Minimum	Maximum		Minimum	Maximum
Band 1	1920	1980	1730	1790	95.0	5950	6130
Band 2	1850	1910	1770	1830	40.0	5630	5810
Band 3	1710	1785	1615	1690	47.5	5225	5450
Band 4	824	849	779	804	22.5	2517	2592
Band 8	880	915	835	870	22.5	2685	2790

Table 5. Second Order Intermodulation Distortion Frequencies

IMD2 Band	f _{rx} (MHz)		f _{BLOCK 1} Minimum (MHz)	f _{BLOCK 2} (MHz)	
	Minimum	Maximum		Minimum	Maximum
Band 1	1920	1980	190	3650	3770
Band 2	1850	1910	80	3620	3740
Band 3	1710	1785	95	3325	3475
Band 5	824	849	45	1603	1653
Band 7	2500	2570	120	4880	5020
Band 8	880	915	45	1715	1785
Band 10	1710	1770	400	3020	3140

Table 6. SKY13489-001 Truth Table¹

State	Active Path	V1 (Bump B1)
0	ANT to RF1	0
1	ANT to RF2	1

¹ "1" = 1.35 V to 3.00 V.
 "0" = -0.1 V to +0.45 V.

Evaluation Board Description

The SKY13489-001 Evaluation Board is used to test the performance of the SKY13489-001 SPDT Switch.

An Evaluation Board schematic diagram is provided in Figure 3. An assembly drawing for the Evaluation Board is shown in Figure 4.

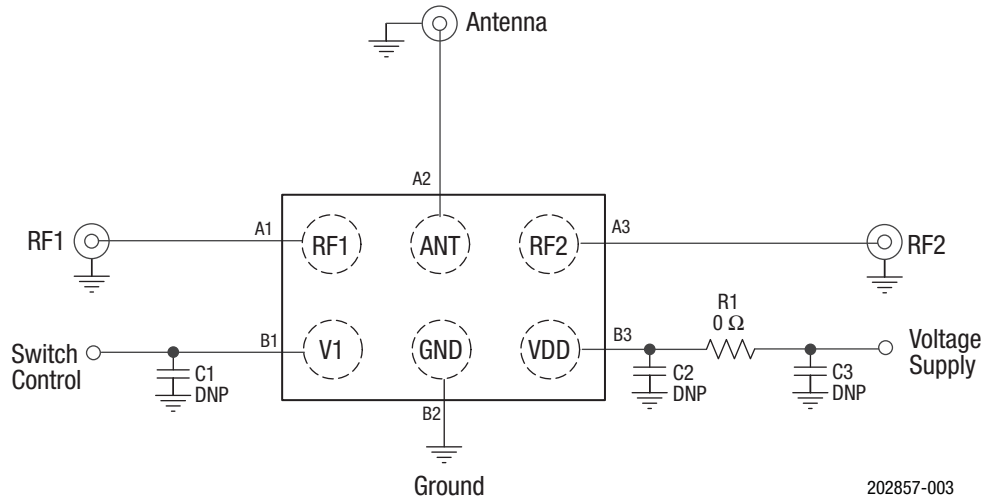

202857-003

Figure 3. SKY13489-001 Evaluation Board Schematic

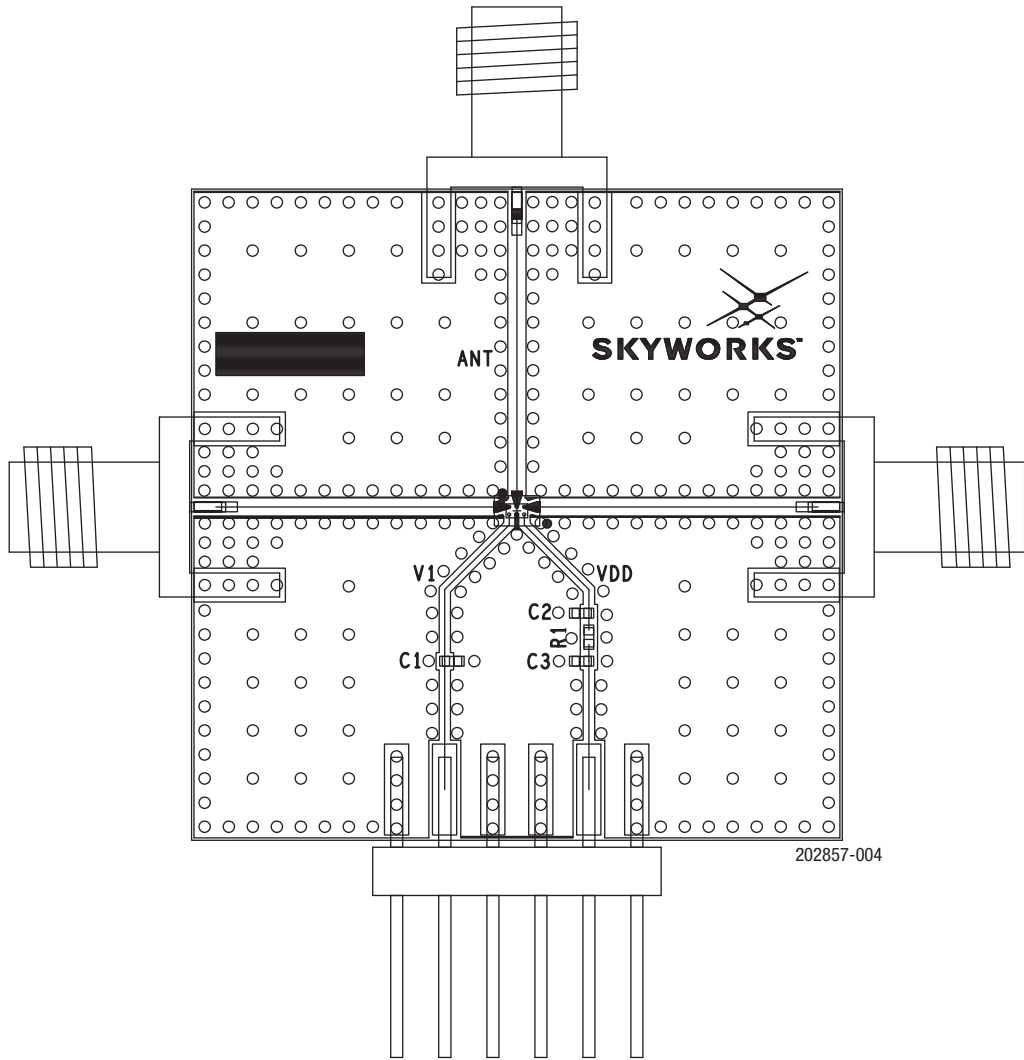

Figure 4. SKY13489-001 Evaluation Board Assembly Diagram

Package Dimensions

The typical part marking for the SKY13489-001 is shown in Figure 5. The PCB layout footprint for the SKY13489-001 is shown in Figure 6. Package dimensions for the SKY13489-001 die are shown in Figure 7, and tape and reel dimensions are provided in Figure 8.

Package and Handling Information

Instructions on the shipping container label regarding exposure to moisture after the container seal is broken must be followed. Otherwise, problems related to moisture absorption may occur when the part is subjected to high temperature during solder assembly.

The SKY13489-001 is rated to Moisture Sensitivity Level 1 (MSL1) at 260 °C. It can be used for lead or lead-free soldering. For additional information, refer to the Skyworks Application Note, *Wafer Level Chip Scale Packages: SMT Process Guidelines and Handling Considerations*, document number 201676.

Care must be taken when attaching this product, whether it is done manually or in a production solder reflow environment. Production quantities of this product are shipped in a standard tape and reel format.

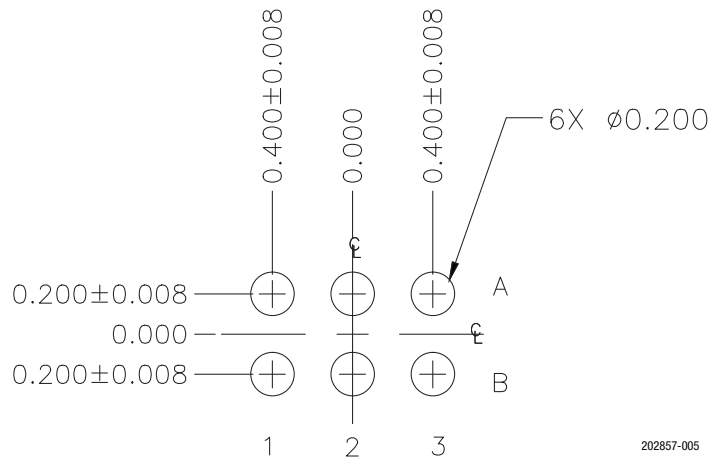

Figure 5. SKY13489-001 PCB Layout Footprint

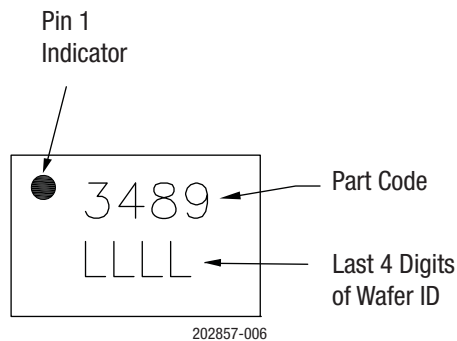
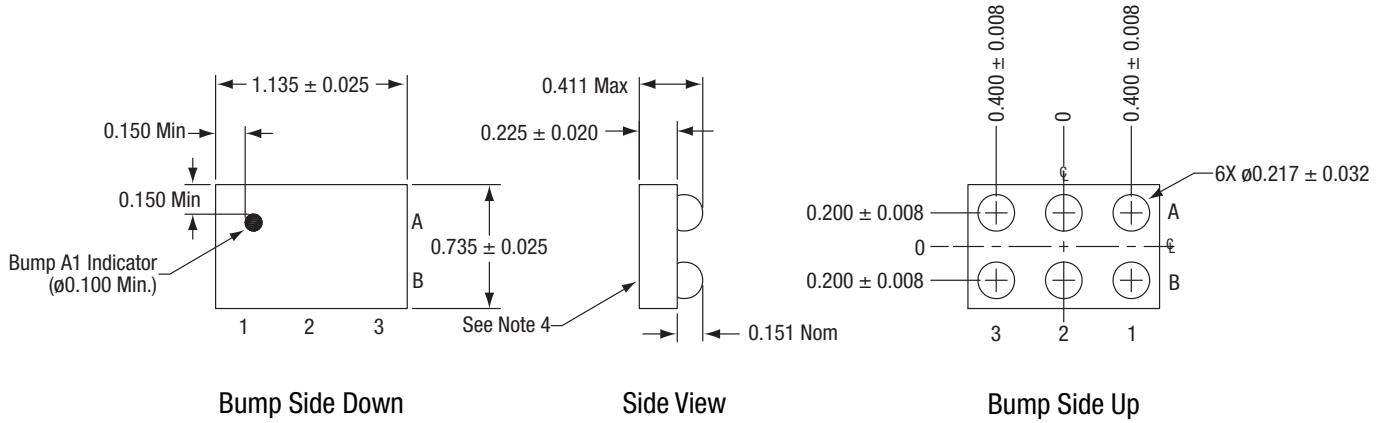

Figure 6. Typical Part Marking



Notes:

1. All measurements are in millimeters.
2. Marking shown is for package orientation reference only.
3. Ball height tolerance is $\pm 10\%$ of nominal ball height.
4. Package thickness includes backside laminate film.

202857-007

Figure 7. SKY13489-001 Package Dimensions

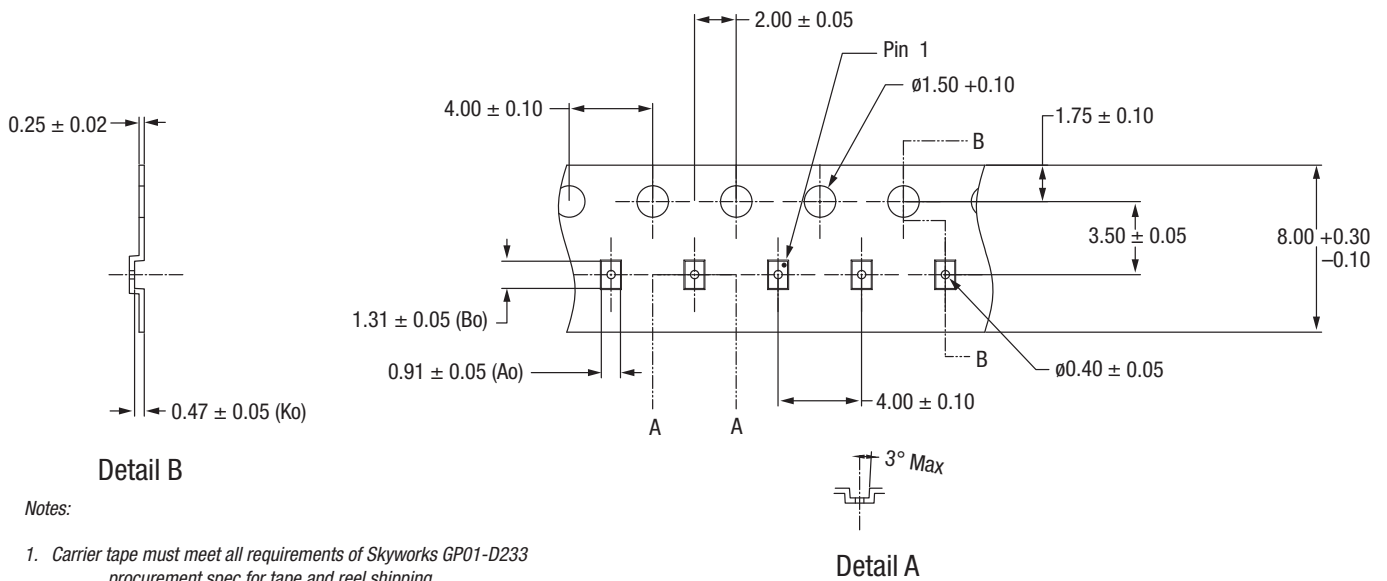

Notes:

1. Carrier tape must meet all requirements of Skyworks GP01-D233 procurement spec for tape and reel shipping.
2. Carrier tape material: black conductive polystyrene or polycarbonate.
3. Cover tape material: transparent conductive.
4. ESD surface resistivity must meet GP01-D233.
5. 10-sprocket hole pitch cumulative tolerance: ± 0.20 mm.
6. Pocket position relative to sprocket hole measured as true position of pocket.
7. All dimensions are in millimeters.

202857-008

Figure 8. SKY13489-001 Tape and Reel Dimensions

Ordering Information

Model Name	Manufacturing Part Number	Evaluation Board Part Number
SKY13489-001: 0.7 to 2.7 GHz SPDT Switch in a WLCSP Package	SKY13489-001	SKY13489-001-EVB

Copyright © 2014-2015, 2017 Skyworks Solutions, Inc. All Rights Reserved.

Information in this document is provided in connection with Skyworks Solutions, Inc. ("Skyworks") products or services. These materials, including the information contained herein, are provided by Skyworks as a service to its customers and may be used for informational purposes only by the customer. Skyworks assumes no responsibility for errors or omissions in these materials or the information contained herein. Skyworks may change its documentation, products, services, specifications or product descriptions at any time, without notice. Skyworks makes no commitment to update the materials or information and shall have no responsibility whatsoever for conflicts, incompatibilities, or other difficulties arising from any future changes.

No license, whether express, implied, by estoppel or otherwise, is granted to any intellectual property rights by this document. Skyworks assumes no liability for any materials, products or information provided hereunder, including the sale, distribution, reproduction or use of Skyworks products, information or materials, except as may be provided in Skyworks Terms and Conditions of Sale.

THE MATERIALS, PRODUCTS AND INFORMATION ARE PROVIDED "AS IS" WITHOUT WARRANTY OF ANY KIND, WHETHER EXPRESS, IMPLIED, STATUTORY, OR OTHERWISE, INCLUDING FITNESS FOR A PARTICULAR PURPOSE OR USE, MERCHANTABILITY, PERFORMANCE, QUALITY OR NON-INFRINGEMENT OF ANY INTELLECTUAL PROPERTY RIGHT; ALL SUCH WARRANTIES ARE HEREBY EXPRESSLY DISCLAIMED. SKYWORKS DOES NOT WARRANT THE ACCURACY OR COMPLETENESS OF THE INFORMATION, TEXT, GRAPHICS OR OTHER ITEMS CONTAINED WITHIN THESE MATERIALS. SKYWORKS SHALL NOT BE LIABLE FOR ANY DAMAGES, INCLUDING BUT NOT LIMITED TO ANY SPECIAL, INDIRECT, INCIDENTAL, STATUTORY, OR CONSEQUENTIAL DAMAGES, INCLUDING WITHOUT LIMITATION, LOST REVENUES OR LOST PROFITS THAT MAY RESULT FROM THE USE OF THE MATERIALS OR INFORMATION, WHETHER OR NOT THE RECIPIENT OF MATERIALS HAS BEEN ADVISED OF THE POSSIBILITY OF SUCH DAMAGE.

Skyworks products are not intended for use in medical, lifesaving or life-sustaining applications, or other equipment in which the failure of the Skyworks products could lead to personal injury, death, physical or environmental damage. Skyworks customers using or selling Skyworks products for use in such applications do so at their own risk and agree to fully indemnify Skyworks for any damages resulting from such improper use or sale.

Customers are responsible for their products and applications using Skyworks products, which may deviate from published specifications as a result of design defects, errors, or operation of products outside of published parameters or design specifications. Customers should include design and operating safeguards to minimize these and other risks. Skyworks assumes no liability for applications assistance, customer product design, or damage to any equipment resulting from the use of Skyworks products outside of stated published specifications or parameters.

Skyworks and the Skyworks symbol are trademarks or registered trademarks of Skyworks Solutions, Inc., in the United States and other countries. Third-party brands and names are for identification purposes only, and are the property of their respective owners. Additional information, including relevant terms and conditions, posted at www.skyworksinc.com, are incorporated by reference.

Данный компонент на территории Российской Федерации

Вы можете приобрести в компании MosChip.

Для оперативного оформления запроса Вам необходимо перейти по данной ссылке:

<http://moschip.ru/get-element>

Вы можете разместить у нас заказ для любого Вашего проекта, будь то серийное производство или разработка единичного прибора.

В нашем ассортименте представлены ведущие мировые производители активных и пассивных электронных компонентов.

Нашей специализацией является поставка электронной компонентной базы двойного назначения, продукции таких производителей как XILINX, Intel (ex.ALTERA), Vicor, Microchip, Texas Instruments, Analog Devices, Mini-Circuits, Amphenol, Glenair.

Сотрудничество с глобальными дистрибьюторами электронных компонентов, предоставляет возможность заказывать и получать с международных складов практически любой перечень компонентов в оптимальные для Вас сроки.

На всех этапах разработки и производства наши партнеры могут получить квалифицированную поддержку опытных инженеров.

Система менеджмента качества компании отвечает требованиям в соответствии с ГОСТ Р ИСО 9001, ГОСТ РВ 0015-002 и ЭС РД 009

Офис по работе с юридическими лицами:

105318, г.Москва, ул.Щербаковская д.3, офис 1107, 1118, ДЦ «Щербаковский»

Телефон: +7 495 668-12-70 (многоканальный)

Факс: +7 495 668-12-70 (доб.304)

E-mail: info@moschip.ru

Skype отдела продаж:

moschip.ru

moschip.ru_4

moschip.ru_6

moschip.ru_9