

Amplifier, CATV Return Path Differential 5 - 300 MHz

Rev. V1

Features

- 19 dB Gain
- 7 dB Noise Figure
- 8 V Bias
- Low Distortion
- Wide Bandwidth for DOCSIS 3.1
- Lead-Free 3 mm 16-lead PQFN Package
- Halogen-Free “Green” Mold Compound
- RoHS* Compliant and 260°C Reflow Compatible

Description

The MAAM-011156 is a GaAs single stage differential amplifier assembled in a lead-free 3 mm 16-lead PQFN plastic package. This amplifier provides 19 dB of gain while biased at +8 volts and also offers a power down function. The amplifier provides excellent linearity and high output power with greater than 30 dB MER for 64 QAM modulation with 16 channels and 58 dBmV per channel.

It is ideally suited for use in CATV return path amplifier applications especially the wide bandwidth of DOCSIS 3.1.

Ordering Information^{1,2}

Part Number	Package
MAAM-011156-TR1000	1000 piece reel
MAAM-011156-TR3000	3000 piece reel
MAAM-011156-001SMB	Sample Board

1. Reference Application Note M513 for reel size information.
2. All sample boards include 5 loose parts.

*Restrictions on Hazardous Substances,
European Union Directive 2011/65/EU.

Functional Schematic

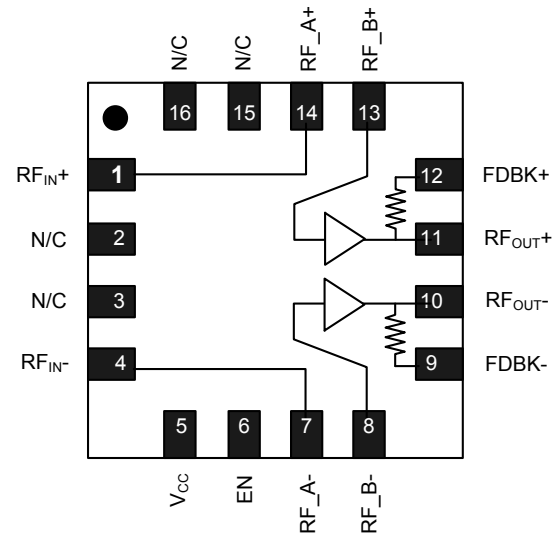

Pin Designations

Pin	Function	Function
1	RF _{IN+}	RF Input+
2	N/C	No Connection
3	N/C	No Connection
4	RF _{IN-}	RF Input-
5	V _{CC}	Bias Voltage
6	EN	Enable
7	RF _{A-}	RF Input Node A-
8	RF _{B-}	RF Input Node B-
9	FDBK-	Feedback-
10	RF _{OUT-}	RF Output-
11	RF _{OUT+}	RF Output+
12	FDBK+	Feedback+
13	RF _{B+}	RF Input Node B+
14	RF _{A+}	RF Input Node A+
15	N/C	No Connection
16	N/C	No Connection
17	Paddle ³	Ground

3. The exposed paddle centered on the package bottom must be connected to RF and DC ground.

Amplifier, CATV Return Path Differential 5 - 300 MHz

Rev. V1

Electrical Specifications: $T_A = 25^\circ\text{C}$, $V_{CC} = +8\text{ V}$, $EN = 5\text{ V}$

Parameter	Test Conditions	Units	Min.	Typ.	Max.
Gain	-10 dBm P_{IN} , 100 MHz 250 MHz	dB	18.5 18.0	19.5 19.5	21.5 21.0
Noise Figure	5 - 300 MHz	dB	—	7	—
Input Return Loss	5 - 300 MHz	dB	—	20	—
Output Return Loss	5 - 300 MHz	dB	—	18	—
Reverse Isolation	5 - 300 MHz	dB	—	26	—
64 QAM MER	16 Channels (5 - 250 MHz), 57 dBmV/Ch.	dBm	30	35	—
P1dB	5 - 300 MHz	dBm	—	28	—
OIP3	Two tones at 1 MHz spacing, $P_{OUT} = +12\text{ dBm}$ per tone, 200 MHz	dBm	—	44	—
OIP2	Two tones at 1 MHz spacing, $P_{OUT} = +12\text{ dBm}$ per tone, 5 - 300 MHz	dBm	—	78	—
I_{CC}	$V_{CC} = +8\text{ V}$, $EN = 5\text{ V}$	mA	—	210	240
I_{CC_OFF}	$V_{CC} = +8\text{ V}$, $EN = 0\text{ V}$	mA	—	1	—

Absolute Maximum Ratings^{4,5}

Parameter	Absolute Maximum
Input Power	+11 dBm
Bias Voltage	+10 V
Operating Temperature	-40°C to +85°C
Storage Temperature	-65°C to +125°C

- Exceeding any one or combination of these limits may cause permanent damage to this device.
- MACOM does not recommend sustained operation near these survivability limits.

Handling Procedures

Please observe the following precautions to avoid damage:

Static Sensitivity

Gallium Arsenide Integrated Circuits are sensitive to electrostatic discharge (ESD) and can be damaged by static electricity. Proper ESD control techniques should be used when handling these HBM Class 1B devices.

Amplifier, CATV Return Path Differential 5 - 300 MHz

Rev. V1

Schematic PCB Layout

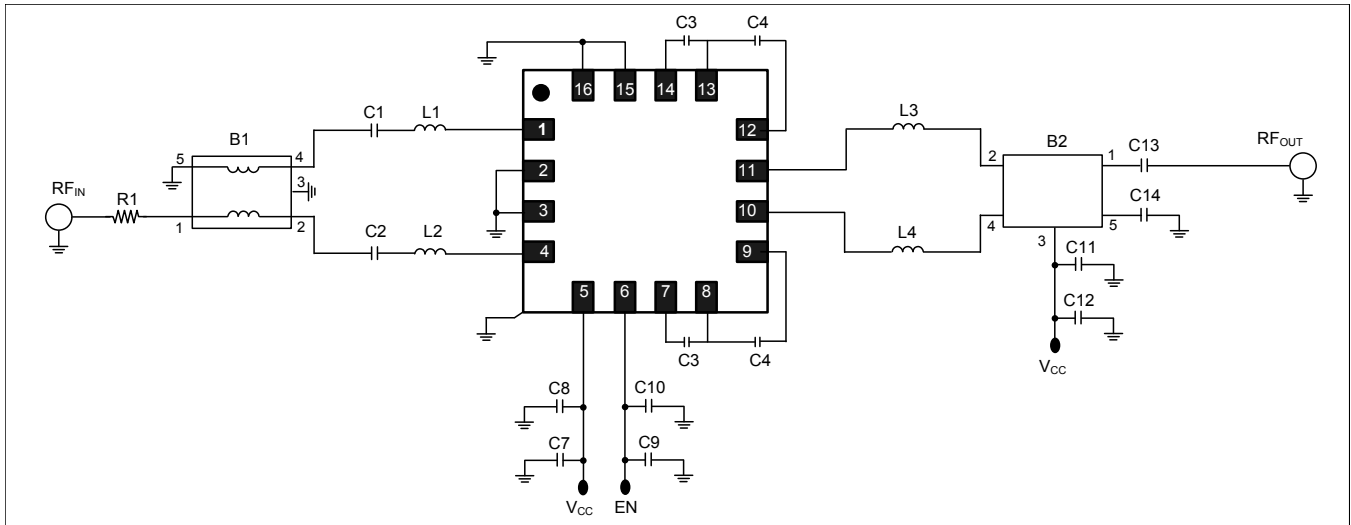

Sample Board

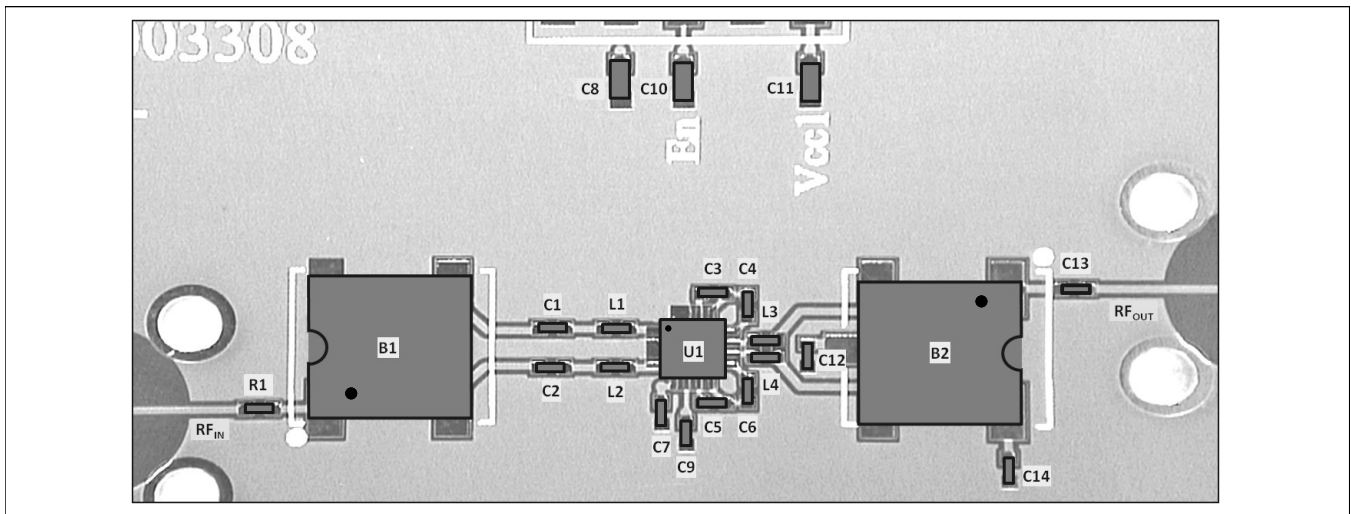

Off-Chip Component Values

Component	Value	Package
C1-C6,C13	0.01 μ F	0402
C7,C9,C12,C14	0.1 μ F	0402
C8,C10,C11	1 μ F	0603
R1	0 Ω	0402
L1-L4	18 nH	0402
B1-B2	1:2 Transformer Balun, MACOM's MABA-011029	

Typical Performance Curves

Gain

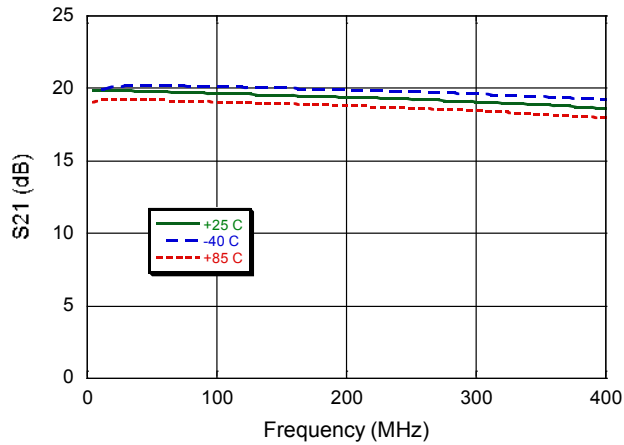

Reverse Isolation

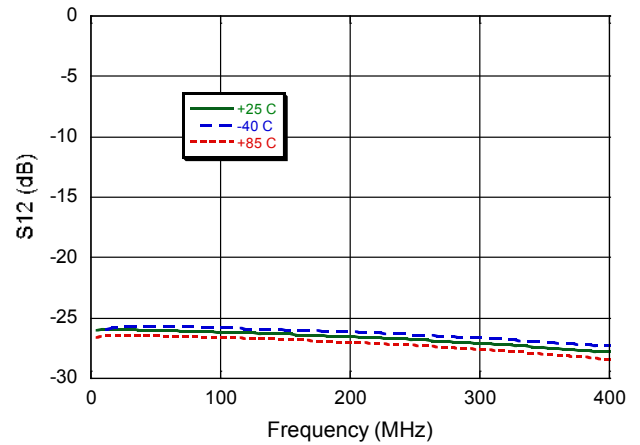

Input Return Loss

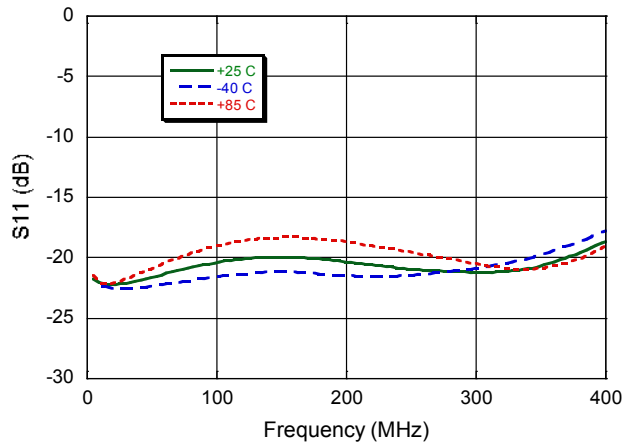

Output Return Loss

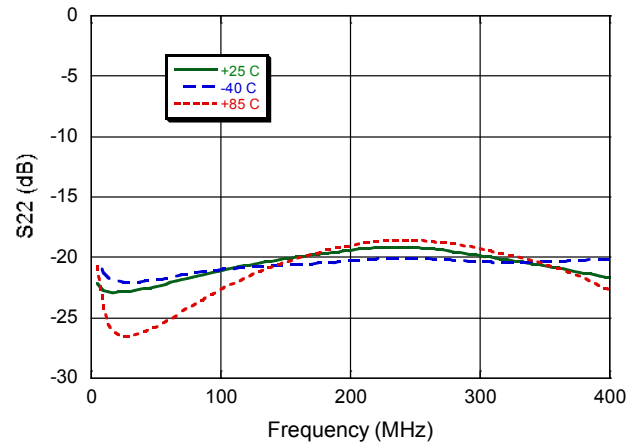

Noise Figure

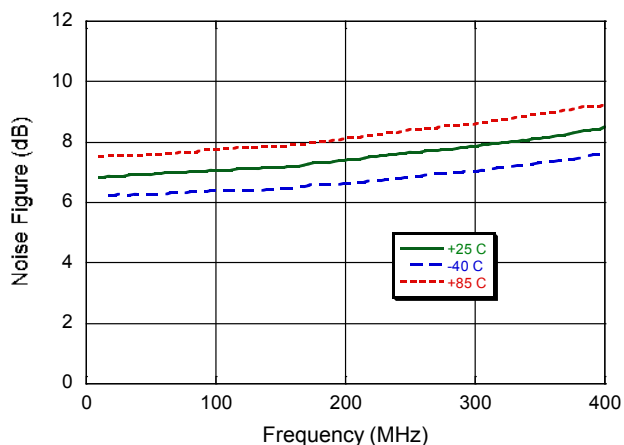

Typical Performance Curves

OIP2 @ $P_{OUT} = 12\text{ dBm}$

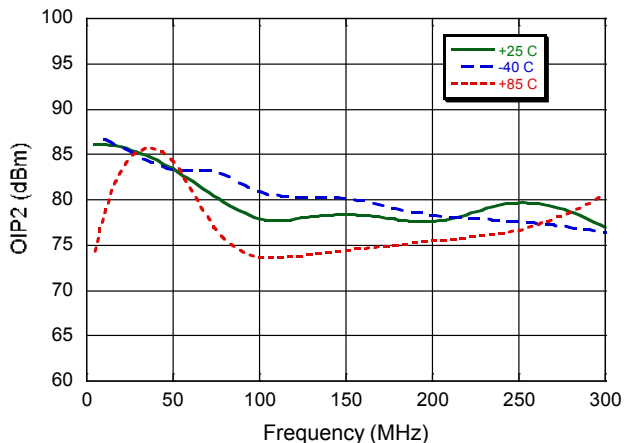

OIP3 @ $P_{OUT} = 12\text{ dBm}$

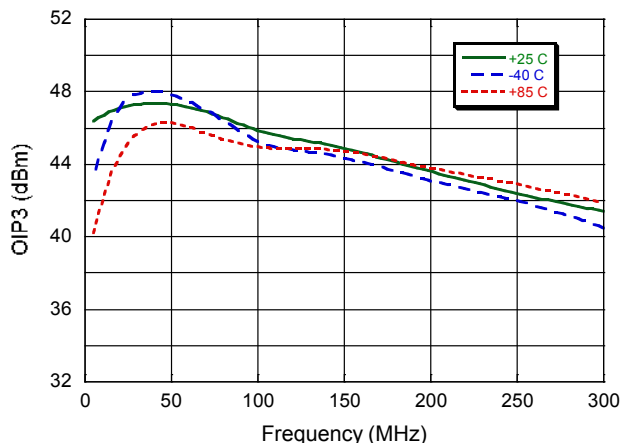

P1dB @ 250 MHz

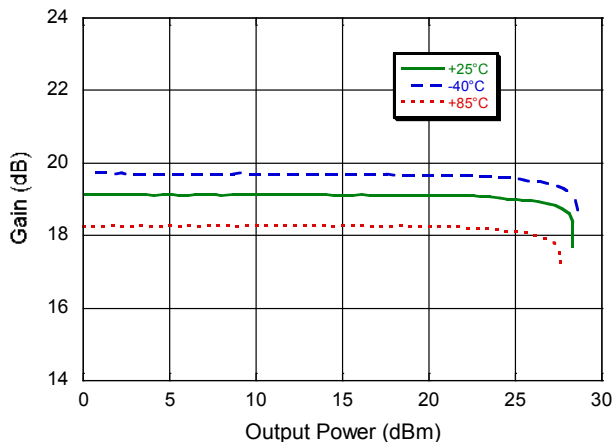

64 QAM Modulation Error Ratio⁶

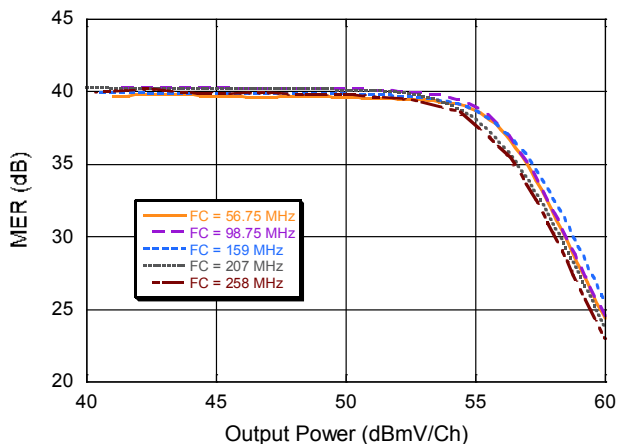

6. Fc is the carrier frequency for 9th of 16 contiguous 6 MHz 64 QAM channels. MER measured on 9th channel.

Lead-Free 3 mm 16-Lead PQFN†

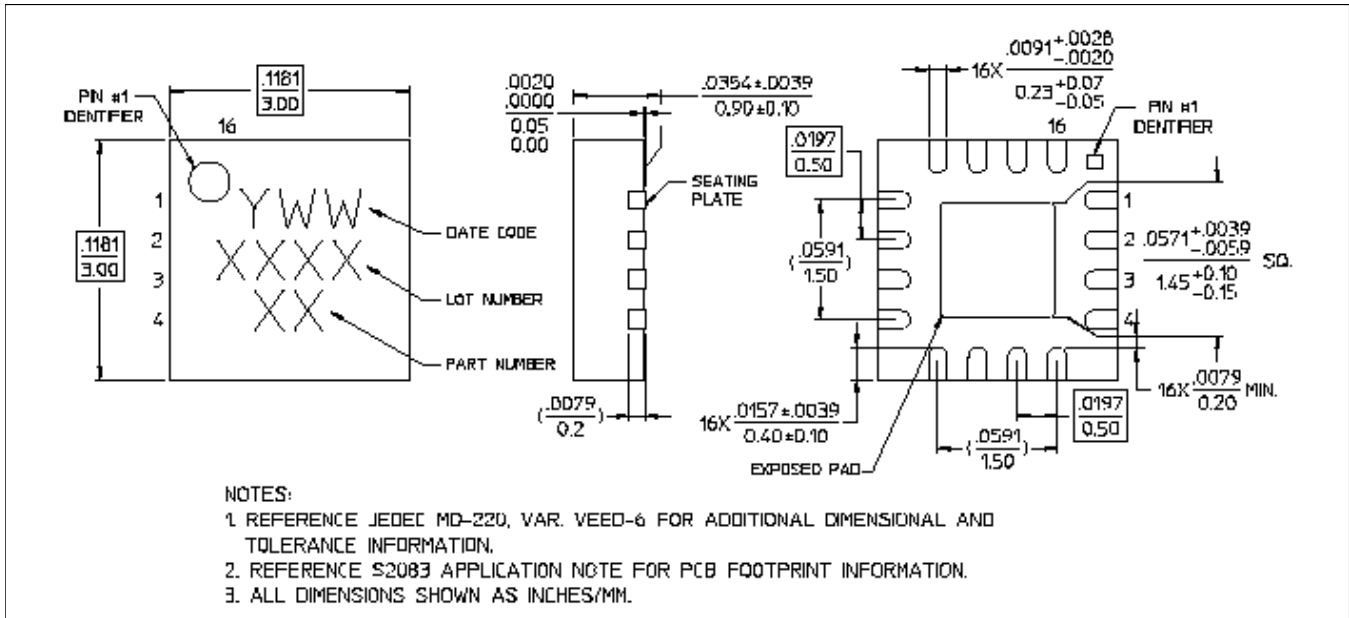

† Reference Application Note S2083 for lead-free solder reflow recommendations.
 Meets JEDEC moisture sensitivity level TBD requirements.
 Plating is 100% matte tin over copper.

Applications Section

15 dB Gain Schematic PCB Layout

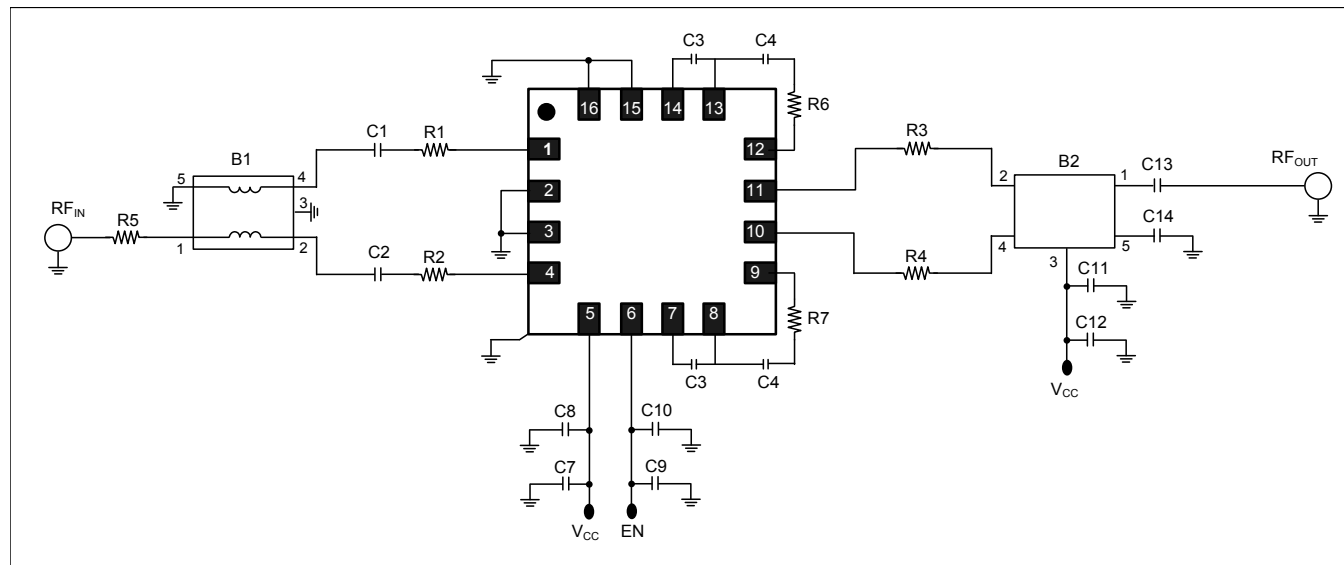

15 dB Gain Off-Chip Component Values

Component	Value	Package
C1-C6,C13	0.01 μ F	0402
C7,C9,C12,C14	0.1 μ F	0402
C8,C10,C11	1 μ F	0603
R1 - R5	0 Ω	0402
R6, R7	560 Ω	0402
B1-B2	1:1 Transformer Balun, MACOM's MABA-009572	

Applications Section

Gain @ 15 dB

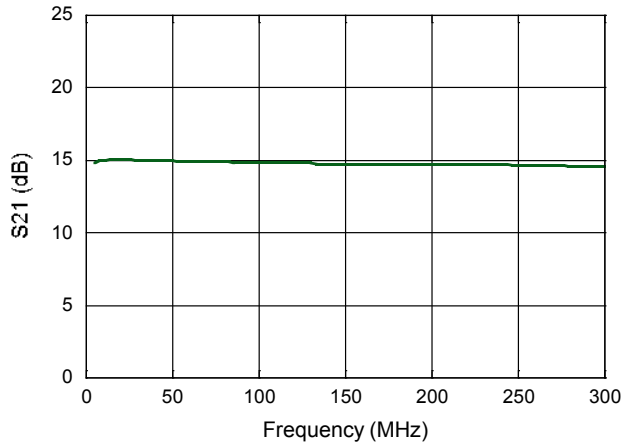

Reverse Isolation with 15 dB Gain

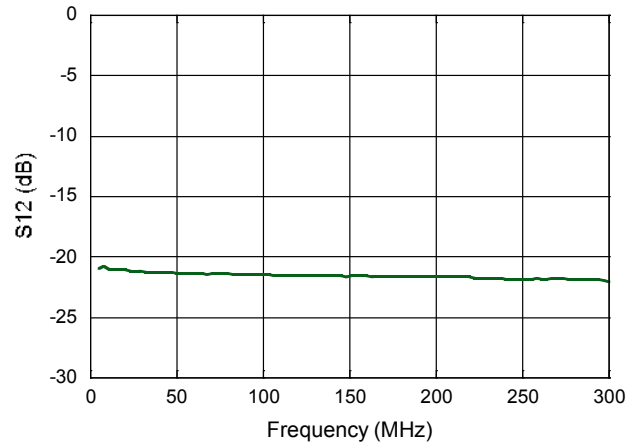

Input Return Loss with 15 dB Gain

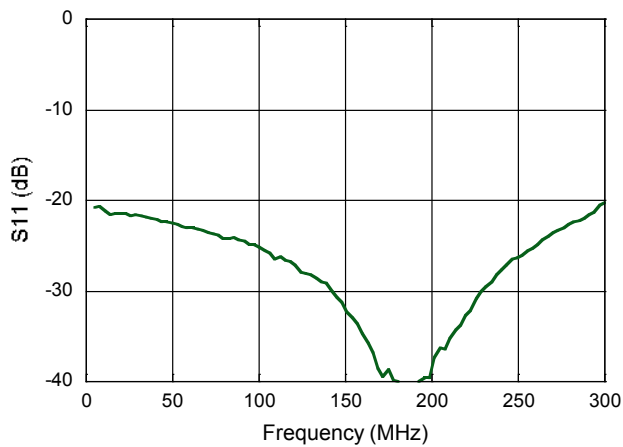

Output Return Loss with 15 dB Gain

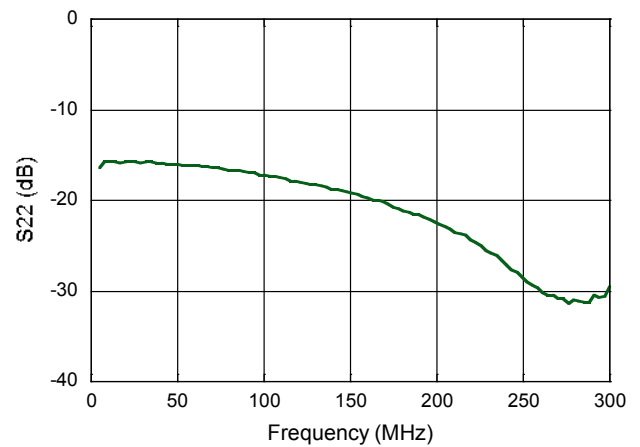

Noise Figure with 15 dB Gain

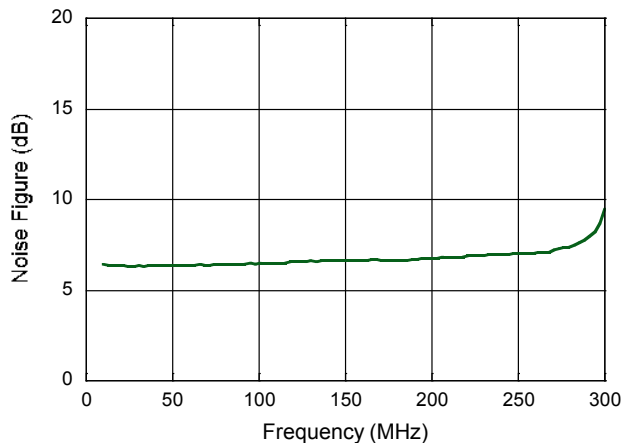

Applications Section

10 dB Gain Schematic PCB Layout

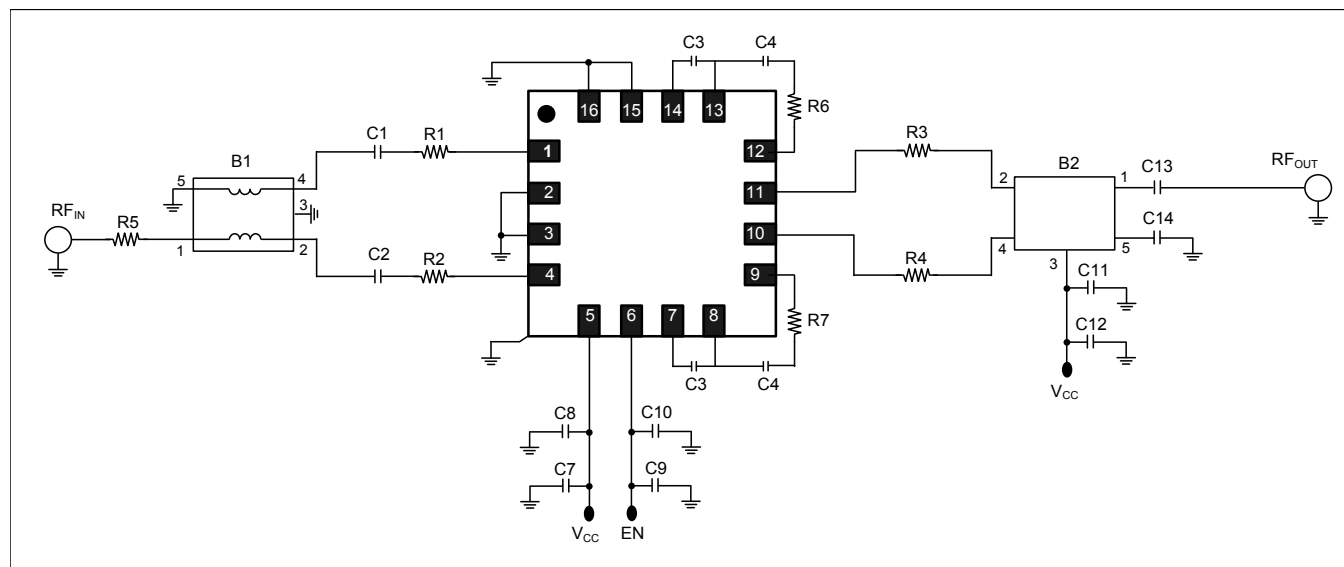

10 dB Gain Off-Chip Component Values

Component	Value	Package
C1-C6,C13	0.01 μ F	0402
C7,C9,C12,C14	0.1 μ F	0402
C8,C10,C11	1 μ F	0603
R1 - R5	0 Ω	0402
R6, R7	160 Ω	0402
B1-B2	1:1 Transformer Balun, MACOM's MABA-009572	

Applications Section

Gain @ 10 dB

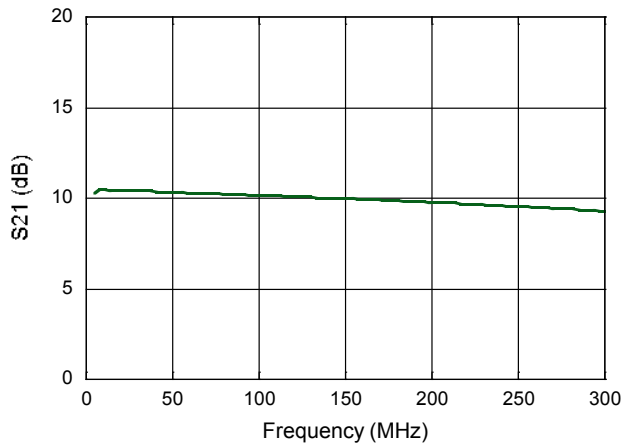

Reverse Isolation with 10 dB Gain

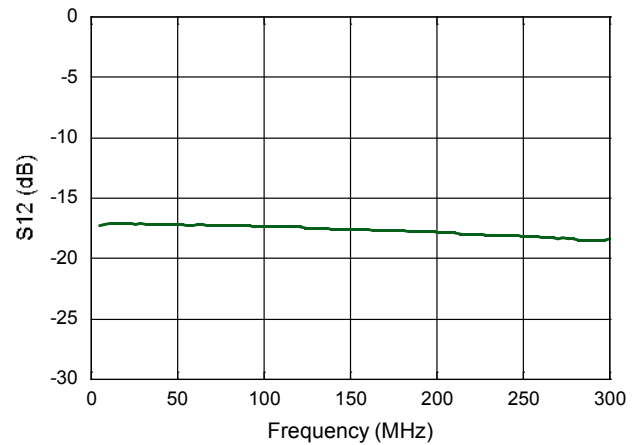

Input Return Loss with 10 dB Gain

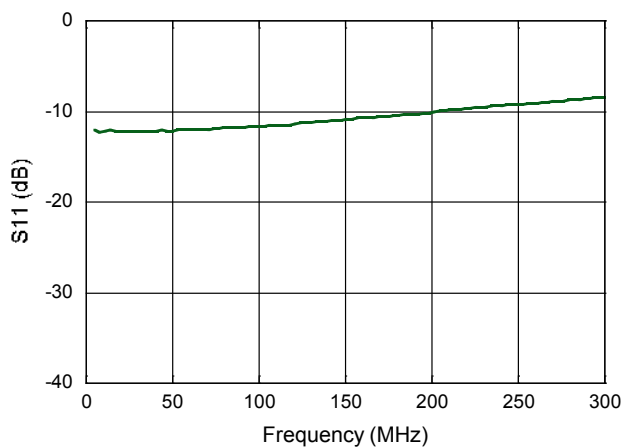

Output Return Loss with 10 dB Gain

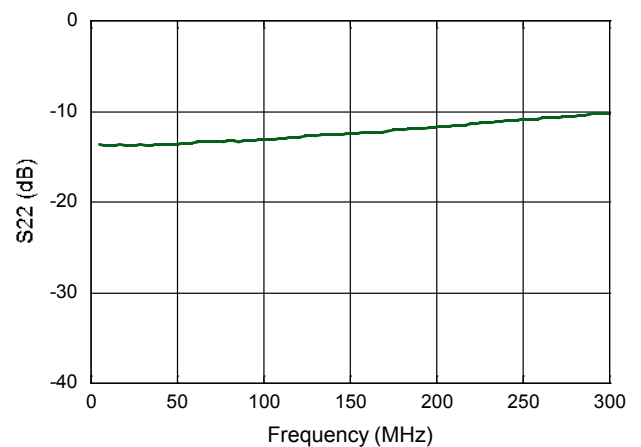

Данный компонент на территории Российской Федерации

Вы можете приобрести в компании MosChip.

Для оперативного оформления запроса Вам необходимо перейти по данной ссылке:

<http://moschip.ru/get-element>

Вы можете разместить у нас заказ для любого Вашего проекта, будь то серийное производство или разработка единичного прибора.

В нашем ассортименте представлены ведущие мировые производители активных и пассивных электронных компонентов.

Нашей специализацией является поставка электронной компонентной базы двойного назначения, продукции таких производителей как XILINX, Intel (ex.ALTERA), Vicor, Microchip, Texas Instruments, Analog Devices, Mini-Circuits, Amphenol, Glenair.

Сотрудничество с глобальными дистрибьюторами электронных компонентов, предоставляет возможность заказывать и получать с международных складов практически любой перечень компонентов в оптимальные для Вас сроки.

На всех этапах разработки и производства наши партнеры могут получить квалифицированную поддержку опытных инженеров.

Система менеджмента качества компании отвечает требованиям в соответствии с ГОСТ Р ИСО 9001, ГОСТ РВ 0015-002 и ЭС РД 009

Офис по работе с юридическими лицами:

105318, г.Москва, ул.Щербаковская д.3, офис 1107, 1118, ДЦ «Щербаковский»

Телефон: +7 495 668-12-70 (многоканальный)

Факс: +7 495 668-12-70 (доб.304)

E-mail: info@moschip.ru

Skype отдела продаж:

moschip.ru

moschip.ru_4

moschip.ru_6

moschip.ru_9