

77 GHz Medium Power Amplifier

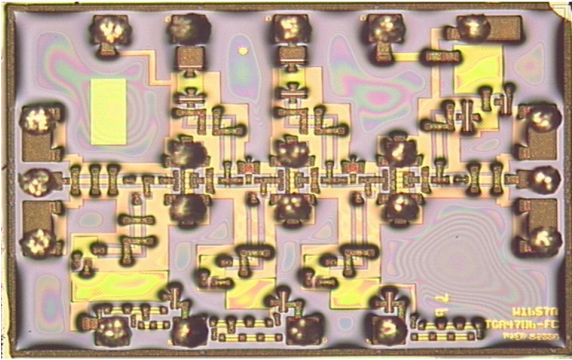

Measured Performance

Bias conditions: $V_d = 3.5\text{ V}$, $I_{dq} = 125\text{ mA}$, $V_g = +0.2\text{ V}$ Typical

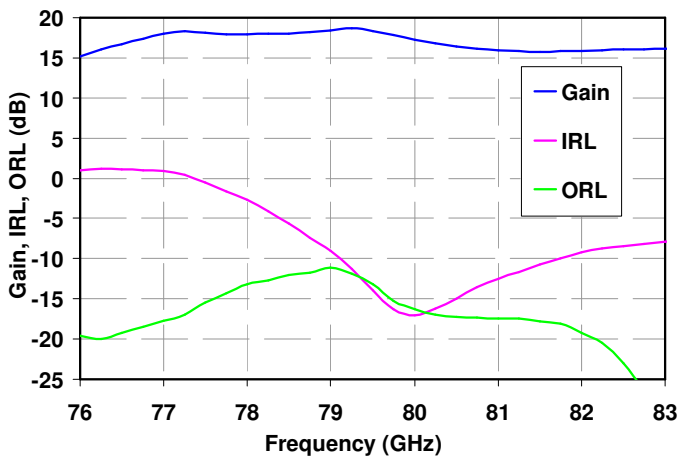
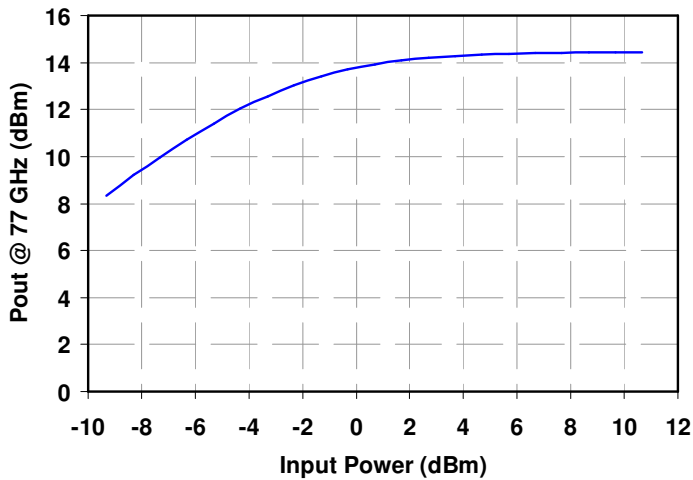

Key Features

- Frequency Range: 76 - 83 GHz
- Psat: 14 dBm at 77 GHz
- Gain: 15 dB
- Bias: $V_d = 3.5\text{ V}$, $V_g = +0.2\text{ V}$, $I_{dq} = 125\text{ mA}$ Typical
- Technology: 0.13 μm pHEMT with front-side Cu/Sn pillars
- Chip Dimensions: 1.86 x 1.37 x 0.38 mm

Primary Applications

- Automotive Radar
- E-Band Communication

Product Description

The TriQuint TGA4706-FC is a flip-chip medium power amplifier designed to operate at the automotive radar frequencies band. The TGA4706-FC is designed using TriQuint's proven 0.13 μm pHEMT process and front-side Cu / Sn pillar technology for simplified assembly and low interconnect inductance. Die reliability is enhanced by using TriQuint's BCB polymeric passivation process.

The TGA4706-FC typically provides 14 dBm saturated output power with 15 dB small signal gain at 77 GHz.

Lead-free and RoHS compliant.

Table I
Absolute Maximum Ratings 1/

Symbol	Parameter	Value	Notes
Vd-Vg	Drain to Gate Voltage	6 V	
Vd	Drain Voltage	4 V	2/
Vg	Gate Voltage Range	-2 to +0.45 V	
Id	Drain Current	240 mA	2/
Ig	Gate Current	4 mA	
Pin	Input Continuous Wave Power	15 dBm	2/

- 1/ These ratings represent the maximum operable values for this device. Stresses beyond those listed under “Absolute Maximum Ratings” may cause permanent damage to the device and / or affect device lifetime. These are stress ratings only, and functional operation of the device at these conditions is not implied.
- 2/ Combinations of supply voltage, supply current, input power, and output power shall not exceed the maximum power dissipation listed in Table IV.

Table II
Recommended Operating Conditions

Symbol	Parameter 1/	Value
Vd	Drain Voltage	3.5 V
Vg	Gate Voltage	+0.2 V
Idq	Drain Current (Quiescent)	125 mA

- 1/ See assembly diagram for bias instructions.

Table III
RF Characterization Table

Bias conditions: $V_d = 3.5\text{ V}$, $V_g = +0.2\text{ V}$, $I_{dq} = 125\text{ mA}$ Typical

SYMBOL	PARAMETER	TEST CONDITIONS	MINIMUM	NOMINAL	UNITS
Gain	Small Signal Gain	$f = 76\text{-}77\text{ GHz}$		15	dB
IRL	Input Return Loss	$f = 76\text{-}77\text{ GHz}$		4	dB
ORL	Output Return Loss	$f = 76\text{-}77\text{ GHz}$		15	dB
Psat	Saturated Output Power	$f = 77\text{ GHz}$		14	dBm
Pout	Output Power (Input Power=-3dBm)	$f = 77\text{ GHz}$	9	12	dBm

Table IV
Power Dissipation and Thermal Properties

Parameter	Test Conditions	Value	Notes
Maximum Power Dissipation	Tbaseplate = 130.0°C	Pd = 0.6 W Tchannel = 150°C Tm = 2.4E+7 Hrs	1/ 2/
Thermal Resistance, θ_{jc} Under RF Drive	Vd = 3.5 V Vg = +0.2 V Idq = 125 mA Pd = 0.438 W Tbaseplate = 85°C	θ_{jc} = 33.3 (°C/W) Tchannel = 93.8°C Tm = 3.2E+10 Hrs	
Mounting Temperature		Refer to Solder Reflow Profiles (pp 10)	
Storage Temperature		-65 to 150°C	

1/ For a median life of 2.4E+07 hours, Power Dissipation is limited to

$$Pd(max) = (150^{\circ}C - Tbase^{\circ}C) / \theta_{jc}$$

2/ Channel operating temperature will directly affect the device median time to failure (MTTF). For maximum life, it is recommended that channel temperatures be maintained at the lowest possible levels.

Median Lifetime (Tm) vs Channel Temperature

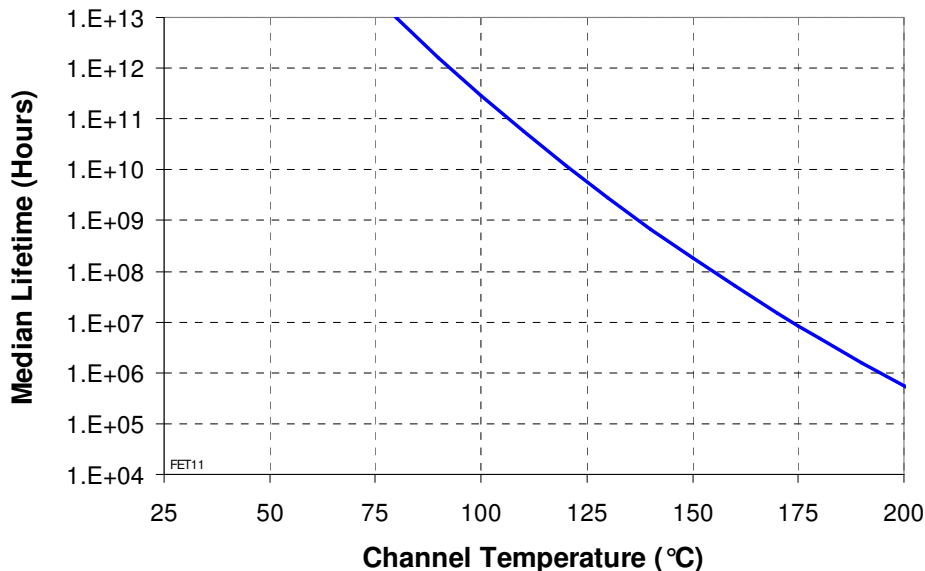

Measured Data on Flipped Die on Carrier Board

Bias conditions: $V_d = 3.5\text{ V}$, $V_g = +0.2\text{ V}$, $I_{dq} = 125\text{ mA Typical}$

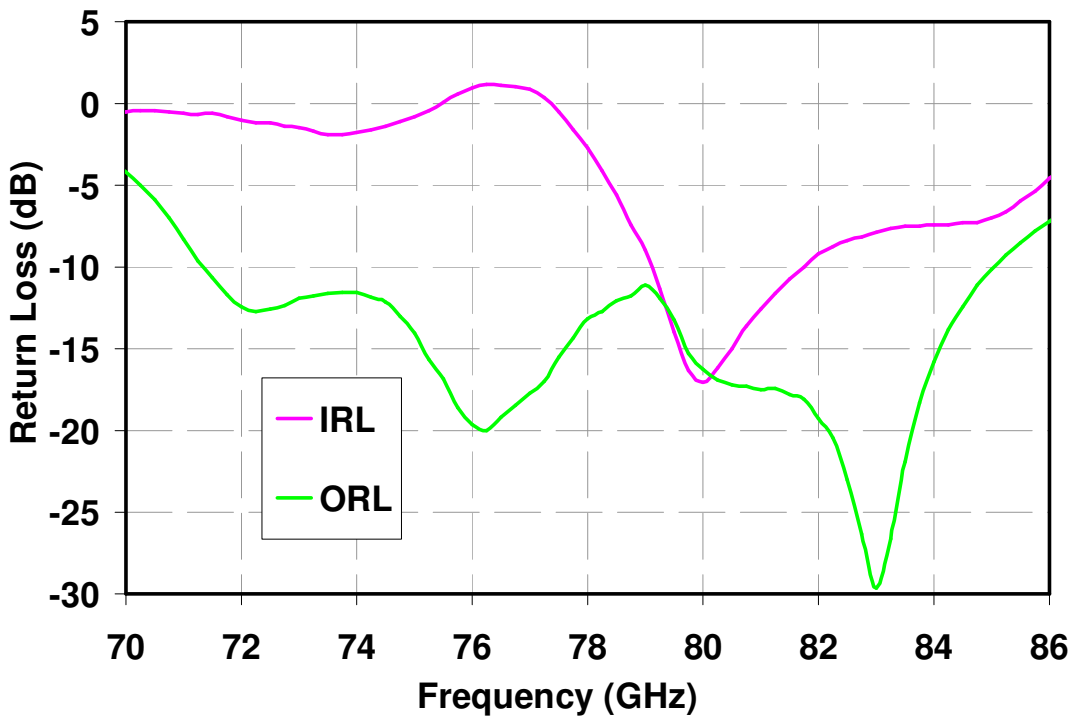
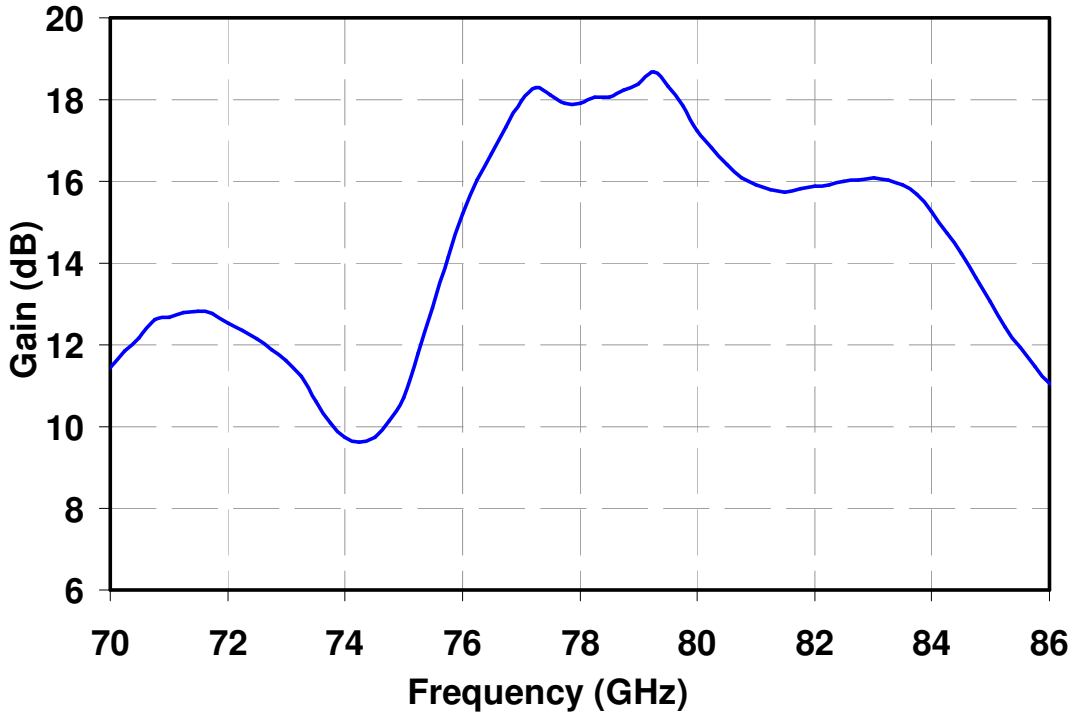

Measured Data on Flipped Die on Carrier Board

Bias conditions: $V_d = 3.5\text{ V}$, $V_g = +0.2\text{ V}$, $I_{dq} = 125\text{ mA}$ Typical

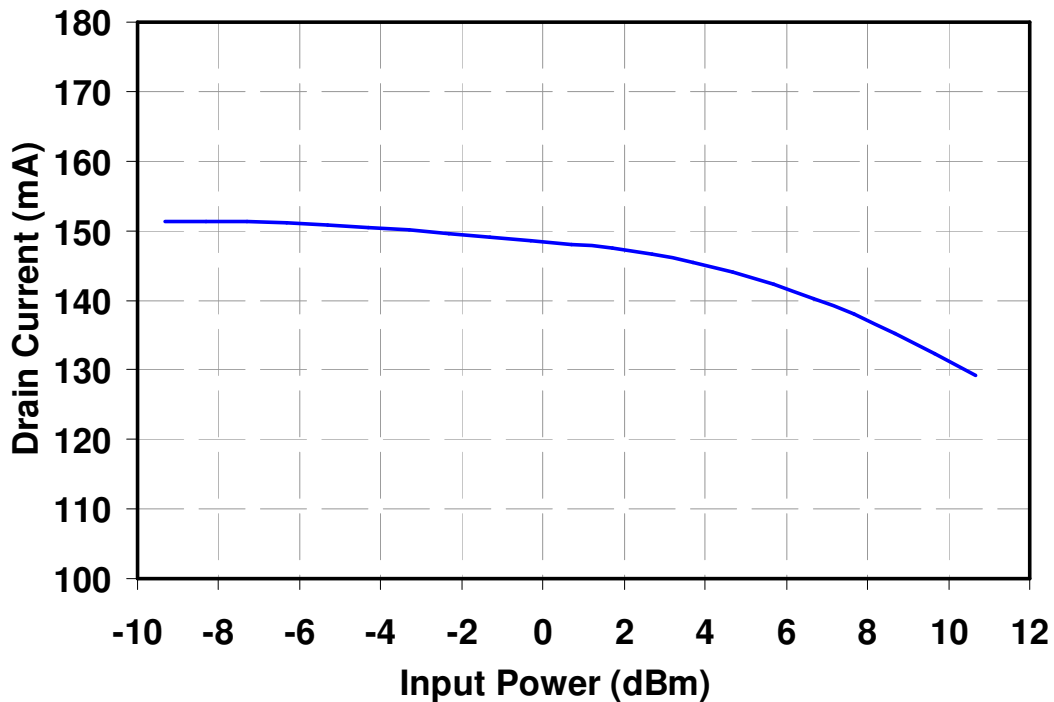
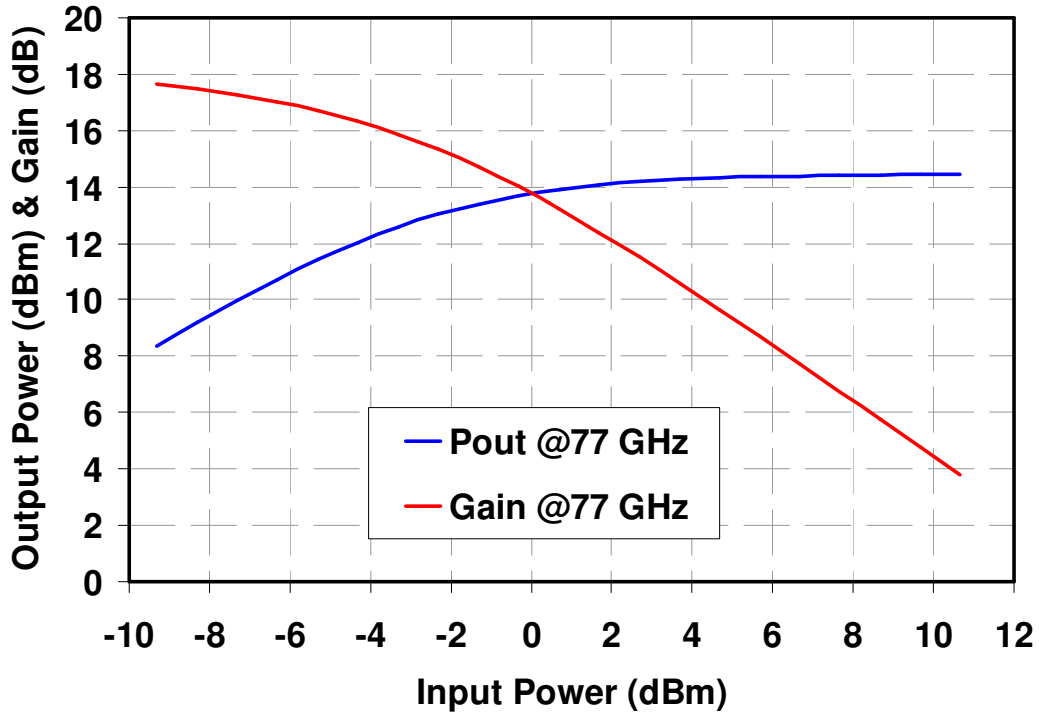

Electrical Schematic

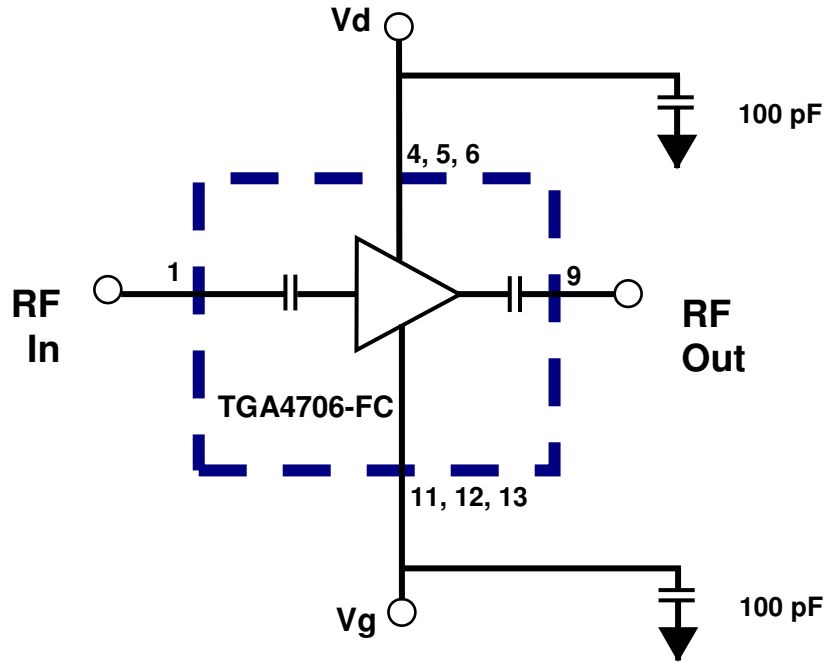

Bias Procedures

Bias-up Procedure

Vg set to -0.6 V

Vd set to +3.5 V

Adjust Vg more positive until Vg is +0.2 V.
Id will be ~ 125 mA

Apply RF signal to input

Bias-down Procedure

Turn off RF supply

Reduce Vg to -0.6V. Ensure Id ~ 0 mA

Turn Vd to 0 V

Mechanical Drawing
Drawing is for chip face-up

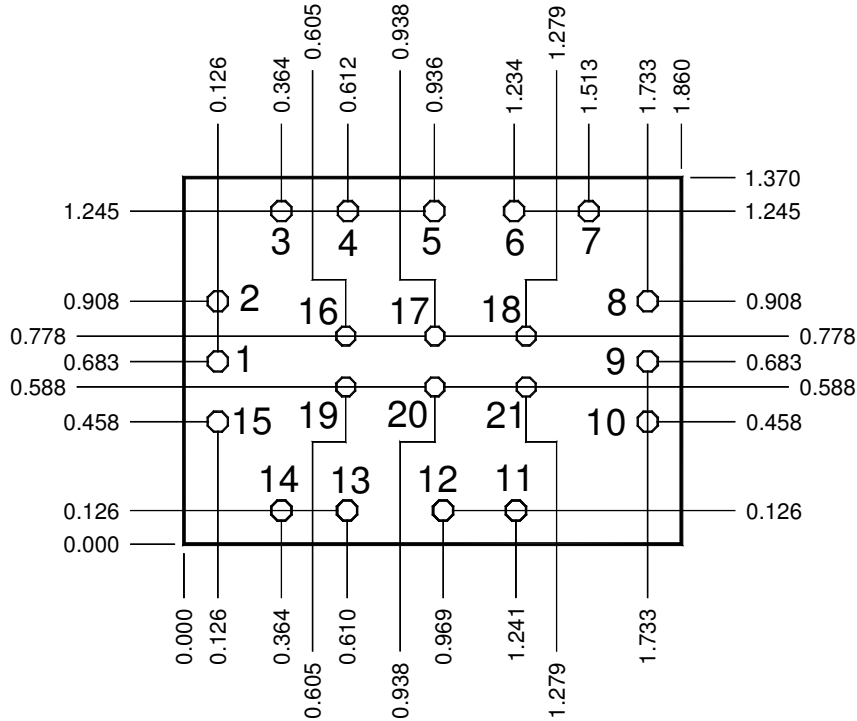

Units: millimeters Thickness: 0.380
Die x,y size tolerance: +/- 0.050
Chip edge to pillar dimensions are shown to center of pillar

Pillar # 1	RF IN	0.075 Ø
Pillar # 9	RF OUT	0.075 Ø
Pillar # 4	Vd1	0.075 Ø
Pillar # 5	Vd2	0.075 Ø
Pillar # 6	Vd3	0.075 Ø
Pillar # 11	Vg3	0.075 Ø
Pillar # 12	Vg2	0.075 Ø
Pillar # 13	Vg1	0.075 Ø
Pillar # 2, 8, 10, 15	RF CPW Ground	0.075 Ø
Pillar # 3, 7, 14, 16, 17, 18, 19, 20, 21	DC Ground	0.075 Ø

GaAs MMIC devices are susceptible to damage from Electrostatic Discharge. Proper precautions should be observed during handling, assembly and test.

Recommended Assembly Diagram

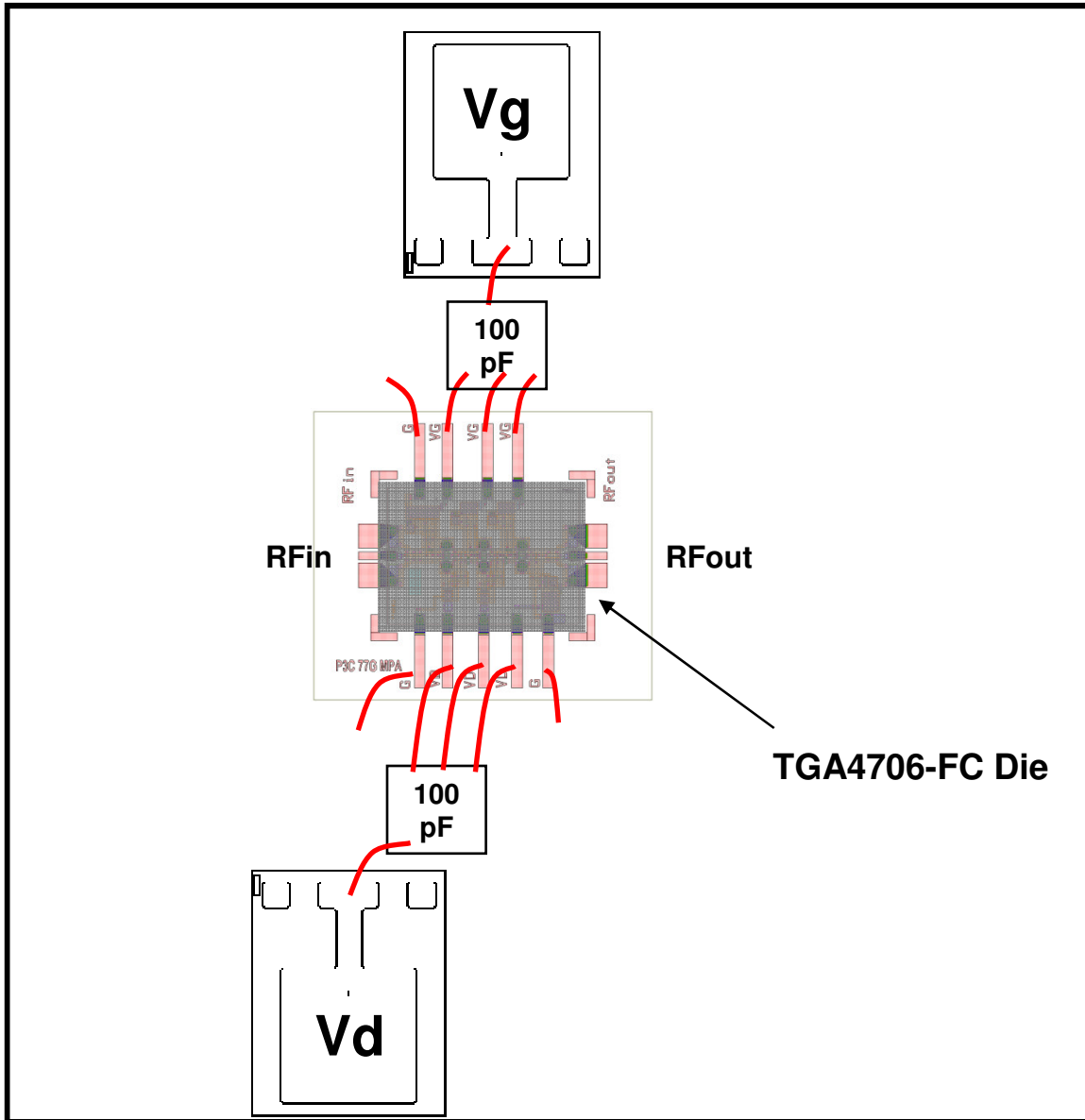

Die is flip-chip soldered to a 15 mil thick alumina test substrate

GaAs MMIC devices are susceptible to damage from Electrostatic Discharge. Proper precautions should be observed during handling, assembly and test.

Assembly Notes

Component placement and die attach assembly notes:

- Vacuum pencils and/or vacuum collets are the preferred method of pick up.
- Air bridges must be avoided during placement.
- Cu pillars on die are 65 um tall with a 22 um tall Sn solder cap.
- Recommended board metallization is evaporated TiW followed by nickel/gold at pillar attach interface. Ni is the adhesion layer for the solder and the gold keeps the Ni from oxidizing. The Au should be kept to a minimum to avoid embrittlement; suggested Au / Sn mass ratio must not exceed 8%.
- Au metallization is not recommended on traces due to solder wicking and consumption concerns. If Au traces are used, a physical solder barrier must be applied or designed into the pad area of the board. The barrier must be sufficient to keep the solder from undercutting the barrier.

Reflow process assembly notes:

- Minimum alloying temperatures 245 °C.
- Repeating reflow cycles is not recommended due to Sn consumption on the first reflow cycle.
- An alloy station or conveyor furnace with an inert atmosphere such as N2 should be used.
- Dip copper pillars in “no-clean flip chip” flux prior to solder attach. Suggest using a high temperature flux. Avoid exposing entire die to flux.
- If screen printing flux, use small apertures and minimize volume of flux applied.
- Coefficient of thermal expansion matching between the MMIC and the substrate/board is critical for long-term reliability.
- Devices must be stored in a dry nitrogen atmosphere.
- Suggested reflow will depend on board material and density.

Typical Reflow Profiles for TriQuint Cu / Sn Pillars

Process	Sn Reflow
Ramp-up Rate	3 °C/sec
Flux Activation Time and Temperature	60 – 120 sec @ 140 – 160 °C
Time above Melting Point (245 °C)	60 – 150 sec
Max Peak Temperature	300 °C
Time within 5 °C of Peak Temperature	10 – 20 sec
Ramp-down Rate	4 – 6 °C/sec

Ordering Information

Part	Package Style
TGA4706-FC	GaAs MMIC Die

GaAs MMIC devices are susceptible to damage from Electrostatic Discharge. Proper precautions should be observed during handling, assembly and test.

Данный компонент на территории Российской Федерации

Вы можете приобрести в компании MosChip.

Для оперативного оформления запроса Вам необходимо перейти по данной ссылке:

<http://moschip.ru/get-element>

Вы можете разместить у нас заказ для любого Вашего проекта, будь то серийное производство или разработка единичного прибора.

В нашем ассортименте представлены ведущие мировые производители активных и пассивных электронных компонентов.

Нашей специализацией является поставка электронной компонентной базы двойного назначения, продукции таких производителей как XILINX, Intel (ex.ALTERA), Vicor, Microchip, Texas Instruments, Analog Devices, Mini-Circuits, Amphenol, Glenair.

Сотрудничество с глобальными дистрибьюторами электронных компонентов, предоставляет возможность заказывать и получать с международных складов практически любой перечень компонентов в оптимальные для Вас сроки.

На всех этапах разработки и производства наши партнеры могут получить квалифицированную поддержку опытных инженеров.

Система менеджмента качества компании отвечает требованиям в соответствии с ГОСТ Р ИСО 9001, ГОСТ РВ 0015-002 и ЭС РД 009

Офис по работе с юридическими лицами:

105318, г.Москва, ул.Щербаковская д.3, офис 1107, 1118, ДЦ «Щербаковский»

Телефон: +7 495 668-12-70 (многоканальный)

Факс: +7 495 668-12-70 (доб.304)

E-mail: info@moschip.ru

Skype отдела продаж:

moschip.ru

moschip.ru_4

moschip.ru_6

moschip.ru_9