

### FEATURES

**Precision Voltage Monitor (4.31 V)**  
**Watchdog Timeout Monitor**  
**Selectable Watchdog Timeout—0.75 ms, 1.5 ms,  
 12.5 ms, 25 ms**  
**Two RESET Outputs**

### APPLICATIONS

**Microprocessor Systems**  
**Computers**  
**Printers**  
**Controllers**  
**Intelligent Instruments**

### FUNCTIONAL BLOCK DIAGRAM

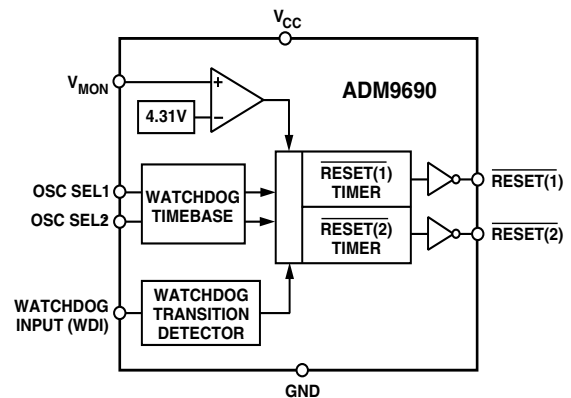

### GENERAL DESCRIPTION

The ADM9690 contains a voltage monitoring comparator and a watchdog timer monitor. It is designed to monitor the 5 V power supply to a microprocessor and the microprocessor operation via a watchdog function.

The voltage monitoring comparator monitors the voltage on  $V_{MON}$ . If it drops outside tolerance, as will happen during a power-fail, two reset signals are generated. Both reset signals go active (low) simultaneously. They will remain active while  $V_{MON}$  is below the threshold, and for 50 ms (RESET(1)) or 60 ms (RESET(2)) after  $V_{MON}$  climbs above the reset threshold. RESET(1) is intended to provide a power-on reset signal for the  $\mu P$  while RESET(2) is used to hold additional circuitry in a reset state until the  $\mu P$  has regained control following a power-up. The voltage monitoring circuitry remains operational with  $V_{CC}$  as low as 2 V.

The watchdog timer monitoring circuit is designed to monitor the activity on the WDI input. This input is normally connected to an output line on the  $\mu P$ . Its function is to check that the microprocessor has not stalled in an infinite loop. If there is a period of inactivity for the watchdog timeout period, both reset outputs are activated. As above, RESET(1) remains low for 50 ms while RESET(2) remains low for an additional 10 ms. The watchdog timer is restarted when RESET(1) goes inactive. The actual watchdog timeout period is adjustable using two select inputs SEL1 and SEL2.

The ADM9690 is available in an 8-lead SOIC package. It is specified over the industrial temperature range.

### REV. A

Information furnished by Analog Devices is believed to be accurate and reliable. However, no responsibility is assumed by Analog Devices for its use, nor for any infringements of patents or other rights of third parties which may result from its use. No license is granted by implication or otherwise under any patent or patent rights of Analog Devices.

# ADM9690—SPECIFICATIONS (V<sub>CC</sub> = Full Operating Range. T<sub>A</sub> = T<sub>MIN</sub> to T<sub>MAX</sub> unless otherwise noted)

Parameter	Min	Typ	Max	Units	Test Conditions/Comments
V <sub>CC</sub> OPERATING VOLTAGE RANGE	4.3		5.5	V	
SUPPLY CURRENT		55	100	μA	
RESET AND WATCHDOG TIMER					
Reset Voltage Threshold	4.2	4.31	4.42	V	V <sub>MON</sub> Falling T <sub>A</sub> = 0°C to +70°C
Reset Threshold Hysteresis		30		mV	
Reset Timeout Delay (t <sub>1</sub> )		50	75	ms	Figure 7, 8
RESET(2) Timeout Delay (t <sub>2</sub> )		10	15	ms	Figure 7, 8
WATCHDOG TIMEOUT PERIOD (TWD)					
	0.4	0.75	1.28	ms	SEL2 = 0, SEL1 = 0
	1.0	1.5	2.4	ms	SEL2 = 0, SEL1 = 1
	9.0	12.5	19	ms	SEL2 = 1, SEL1 = 0
	18	25	38	ms	SEL2 = 1, SEL1 = 1
WDI INPUT PULSEWIDTH	100			ns	V <sub>IL</sub> = 0.4, V <sub>IH</sub> = 3.5 V
RESET(1)/(2) Output Voltage		0.1	0.4	V	I <sub>SINK</sub> = 3.2 mA
		0.3	0.4	V	I <sub>SINK</sub> = 10 mA,
		0.45	0.7	V	I <sub>SINK</sub> = 15 mA,
	3.5			V	I <sub>SOURCE</sub> = 1 μA
WDI INPUT THRESHOLD					
Logic Low			0.8	V	150 ns Pulse
Logic High	3.5			V	150 ns Pulse
WDI Input Current		1.2	5	μA	WDI = V <sub>CC</sub>
	-5	-1.2		μA	WDI = 0 V
SEL1/2 Input Current	-1		+1	μA	SEL = V <sub>CC</sub>
	-10	-5	10	μA	SEL = 0 V

Specifications subject to change without notice.

## ABSOLUTE MAXIMUM RATINGS\*

(T<sub>A</sub> = +25°C unless otherwise noted)

V <sub>CC</sub> .....	-0.3 V to +6 V
V <sub>MON</sub> .....	-0.3 V to V <sub>CC</sub> + 0.3 V
Input Current	
V <sub>CC</sub> .....	200 mA
GND .....	200 mA
Digital Output Current .....	200 mA
Power Dissipation, R-8 SOIC .....	400 mW
θ <sub>JA</sub> Thermal Impedance .....	120°C/W
Industrial (A Version) .....	-40°C to +85°C
Lead Temperature (Soldering, 10 secs) .....	+300°C
Vapor Phase (60 secs) .....	+215°C
Infrared (15 secs) .....	+220°C
Storage Temperature Range .....	-65°C to +150°C
ESD Rating .....	4 kV

\*Stresses above those listed under Absolute Maximum Ratings may cause permanent damage to the device. This is a stress rating only; functional operation of the device at these or any other conditions above those listed in the operational sections of this specification is not implied. Exposure to absolute maximum ratings for extended periods of time may affect device reliability.

## ORDERING GUIDE

Model	Temperature Range	Package Description	Package Option
ADM9690AR	-40°C to +85°C	8-Lead Narrow Body SOIC	SO-8

## PIN CONFIGURATION

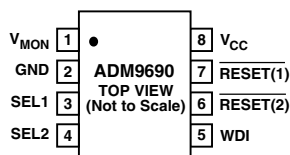

## PIN FUNCTION DESCRIPTIONS

Mnemonic	Function
V <sub>CC</sub>	Power Supply Input; +5 V.
V <sub>MON</sub>	Voltage Monitoring Input.
GND	0 V. Ground reference for all signals.
$\overline{\text{RESET}}(1)$	Logic Output. $\overline{\text{RESET}}(1)$ goes low if V <sub>MON</sub> falls below the Reset Threshold or the Watchdog timer is not serviced within its timeout period. The reset threshold is typically 4.4 V for the ADM9690. $\overline{\text{RESET}}(1)$ remains low for 50 ms after V <sub>CC</sub> returns above the threshold. $\overline{\text{RESET}}(1)$ also goes low for 50 ms if the Watchdog Timer is not serviced within its timeout period.
$\overline{\text{RESET}}(2)$	Logic Output. $\overline{\text{RESET}}(2)$ goes low simultaneously with $\overline{\text{RESET}}(1)$ but remains low for an additional 10 ms.
WDI	Watchdog Input. If an edge is not detected on WDI within the selectable watchdog timeout period, $\overline{\text{RESET}}(1)$ and $\overline{\text{RESET}}(2)$ are forced low for their respective timeout periods. The watchdog timer restarts with each positive or negative going transition on the WDI line. Following a reset it is restarted when $\overline{\text{RESET}}(1)$ goes inactive (high). The Watchdog Timer may be disabled if WDI is left floating or is driven to midsupply.
SEL1, 2	Watchdog Timeout selection inputs. Refer to Table I.

# ADM9690—Typical Performance Curves

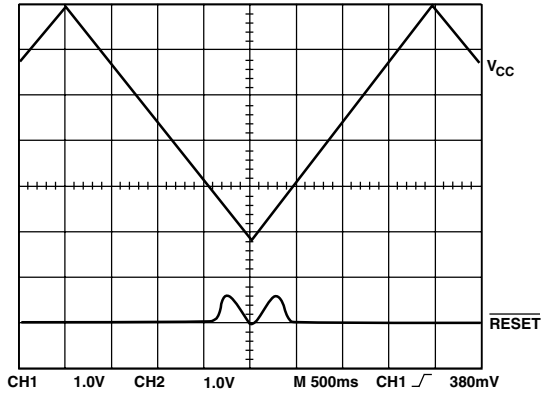

Figure 1. Reset Output Voltage vs. Supply

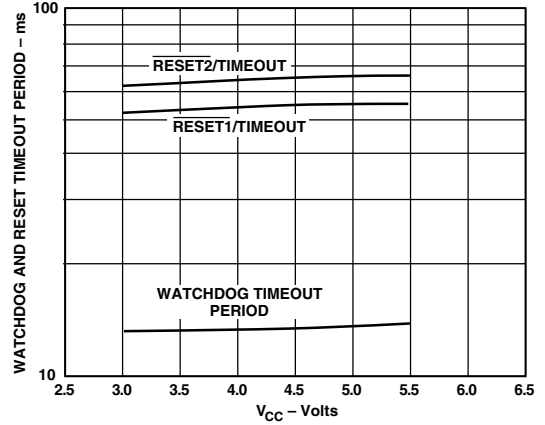

Figure 3. Watchdog and Reset Timeout Period vs. Supply @ -40°C

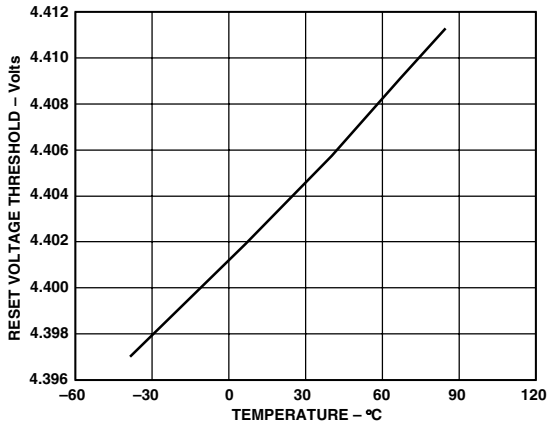

Figure 2. Reset Voltage Threshold vs. Temperature

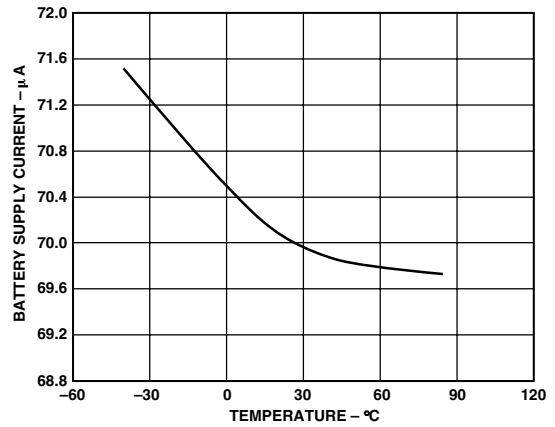

Figure 4. Supply Current vs. Temperature

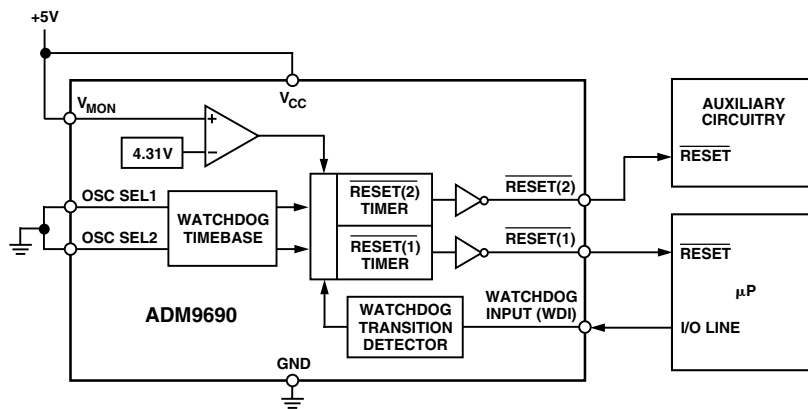

Figure 5. Typical Application Circuit

## POWER SUPPLY AND WATCHDOG MONITORING CIRCUIT

The ADM9690 contains a power supply voltage monitoring comparator and a watchdog timer monitor. Either  $V_{MON}$  dropping outside tolerance or the watchdog timer timing out results in a reset sequence as discussed below. Two reset outputs are provided,  $\overline{RESET}(1)$  and  $\overline{RESET}(2)$ .

### POWER FAIL/POWER-ON $\overline{RESET}$

When  $V_{MON}$  falls below the reset threshold (4.4 V) both  $\overline{RESET}$  outputs are forced low immediately.

On power-up,  $\overline{RESET}(1)$  will remain low for 50 milliseconds after  $V_{MON}$  rises above the reset threshold. This provides a power-on reset for the microprocessor.  $\overline{RESET}(2)$  remains active low for an additional 10 ms.  $\overline{RESET}(1)$  is intended to

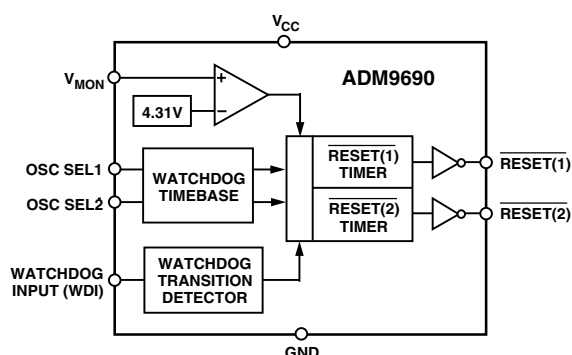

Figure 6. Functional Block Diagram

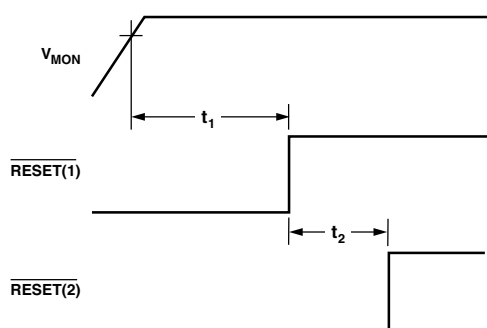

Figure 7. Power-On  $\overline{RESET}$  Timing

provide a power-on reset signal for the  $\mu P$  while  $\overline{RESET}(2)$  is used to hold additional circuitry in a reset state until the  $\mu P$  has regained control following a power-up.

The guaranteed minimum and maximum thresholds for the ADM9690 are 4.3 V and 4.5 V.

### Watchdog Timer $\overline{RESET}$

The watchdog timer circuit monitors the activity of the microprocessor in order to check that it is not stalled in an infinite loop. An output line on the processor may be used to toggle the Watchdog Input (WDI) line. If this line is not toggled within the selected timeout period, both  $\overline{RESET}$  outputs are taken active (low).  $\overline{RESET}(1)$  remains low for 50 ms and  $\overline{RESET}(2)$  remains low for an additional 10 ms. Each transition (either positive-going or negative-going) of WDI after  $\overline{RESET}(1)$  has gone inactive restarts the watchdog timer. The actual watchdog timeout period is adjustable using SEL1 and SEL2. Four timeout periods are selectable. Please refer to Table I.

The watchdog timer is restarted at the end of  $\overline{RESET}(1)$  ( $\overline{RESET}(1)$  going high), whether the reset was caused by lack of activity on WDI or by  $V_{MON}$  falling below the reset threshold.

Table I.

SEL2	SEL1	Watchdog Timeout Period $t_{WD}$ (ms)
0	0	0.75
0	1	1.5
1	0	12.5
1	1	25

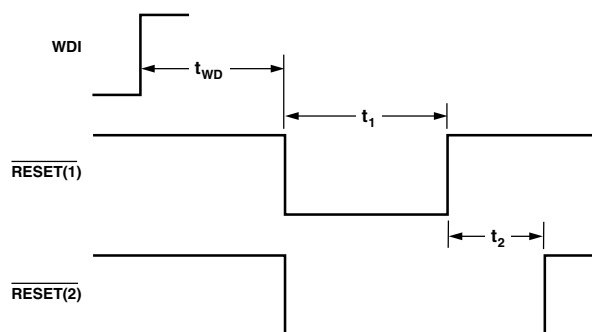
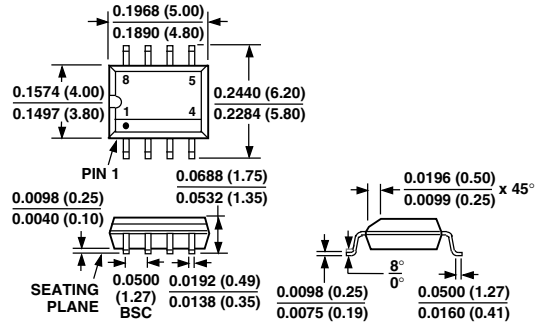

Figure 8. Watchdog  $\overline{RESET}$  Timing

## OUTLINE DIMENSIONS

Dimensions shown in inches and (mm).

### 8-Lead Narrow Body SOIC (SO-8)



## Данный компонент на территории Российской Федерации

### Вы можете приобрести в компании MosChip.

Для оперативного оформления запроса Вам необходимо перейти по данной ссылке:

<http://moschip.ru/get-element>

Вы можете разместить у нас заказ для любого Вашего проекта, будь то серийное производство или разработка единичного прибора.

В нашем ассортименте представлены ведущие мировые производители активных и пассивных электронных компонентов.

Нашей специализацией является поставка электронной компонентной базы двойного назначения, продукции таких производителей как XILINX, Intel (ex.ALTERA), Vicor, Microchip, Texas Instruments, Analog Devices, Mini-Circuits, Amphenol, Glenair.

Сотрудничество с глобальными дистрибьюторами электронных компонентов, предоставляет возможность заказывать и получать с международных складов практически любой перечень компонентов в оптимальные для Вас сроки.

На всех этапах разработки и производства наши партнеры могут получить квалифицированную поддержку опытных инженеров.

Система менеджмента качества компании отвечает требованиям в соответствии с ГОСТ Р ИСО 9001, ГОСТ РВ 0015-002 и ЭС РД 009

### Офис по работе с юридическими лицами:

105318, г.Москва, ул.Щербаковская д.3, офис 1107, 1118, ДЦ «Щербаковский»

Телефон: +7 495 668-12-70 (многоканальный)

Факс: +7 495 668-12-70 (доб.304)

E-mail: [info@moschip.ru](mailto:info@moschip.ru)

Skype отдела продаж:

moschip.ru

moschip.ru\_4

moschip.ru\_6

moschip.ru\_9