



PD70201EVB47F
Evaluation Board User Guide
Revision 0.2

PRODUCTION DATA – Information contained in this document is proprietary to Microsemi and is current as of publication date. This document may not be modified in any way without the express written consent of Microsemi. Product processing does not necessarily include testing of all parameters. Microsemi reserves the right to change the configuration and performance of the product and to discontinue product at any time.



1 About this Guide

This user guide provides both description and operation procedures for Microsemi's PD70201EVB47F board.

This board type is used for evaluating the performance of PD70201 device.

The PD70201ILQ device is supporting both the standard 802.3at PD application interface and a PWM controller that is used for the PD operational voltages DC/DC.

The board is supporting a 47Watt 12V output.

1.1 Audience

This user guide is intended for qualified personnel, meaning operators and technicians who have a background in basic concepts of electronics.

1.2 Organization

This guide is divided into several sections as follows:

• Chapter 1	About this Guide: Describes the objectives, audience, and organization.
• Chapter 2	Introduction: Provides an overview about evaluation board's main functions, features, physical characteristics and ordering information.
• Chapter 3	Physical Description: Provides explanation related to the physical description (switches, jumpers, connectors).
• Chapter 4	Electrical Characteristics: Provides electrical characteristics of the evaluation board.
• Chapter 5	Installation: Provides description of the installation process.
• Chapter 6	Schematic: Provides board schematic diagram
• Chapter 7	List of Materials: Provides board's list of materials.

1.3 Reference Documents

PD70201 datasheet, catalogue number DS_PD70101_70201

2 Introduction

Microsemi’s PD70201ILQ device is part of a family of devices which are targeted for realizing the 802.3at standard PD interface.

The PD interface family of devices includes the following:

Device type	Power capability	Integrates PWM controller
PD70100/A	IEEE 802.3at Type 1 (IEEE 802.3 af level)	No
PD70101/A	IEEE 802.3at Type 1 (IEEE 802.3 af level)	Yes
PD70200	IEEE 802.3at Type 2	No
PD70201	IEEE 802.3at Type 2	Yes

Microsemi’s PD70201EVB47F Evaluation Board (see Figure 2) provides designers with an environment needed to evaluate the performance and implementation of PD applications based on PD70201 device.

The board is using a single PD device PD70201ILQ to support the detection, Class and Power supplying phases on the 4 Pairs of the Cat5 cable. PD70201ILQ supports the current of the 4 Pairs, which is twice the level of a standard IEEE802.3AT Type 2 interfaces.

All necessary steps and connection instructions required to install and operate this board are provided within this document.

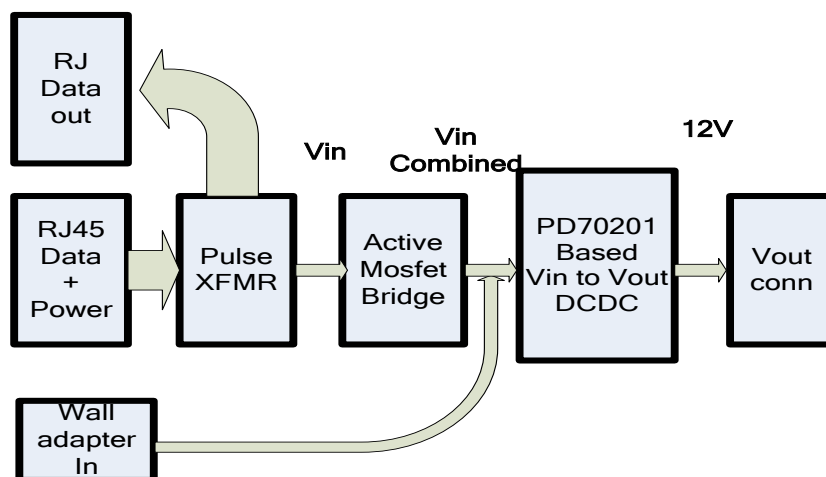

Figure 1: PD70201EVB47F Block Diagram

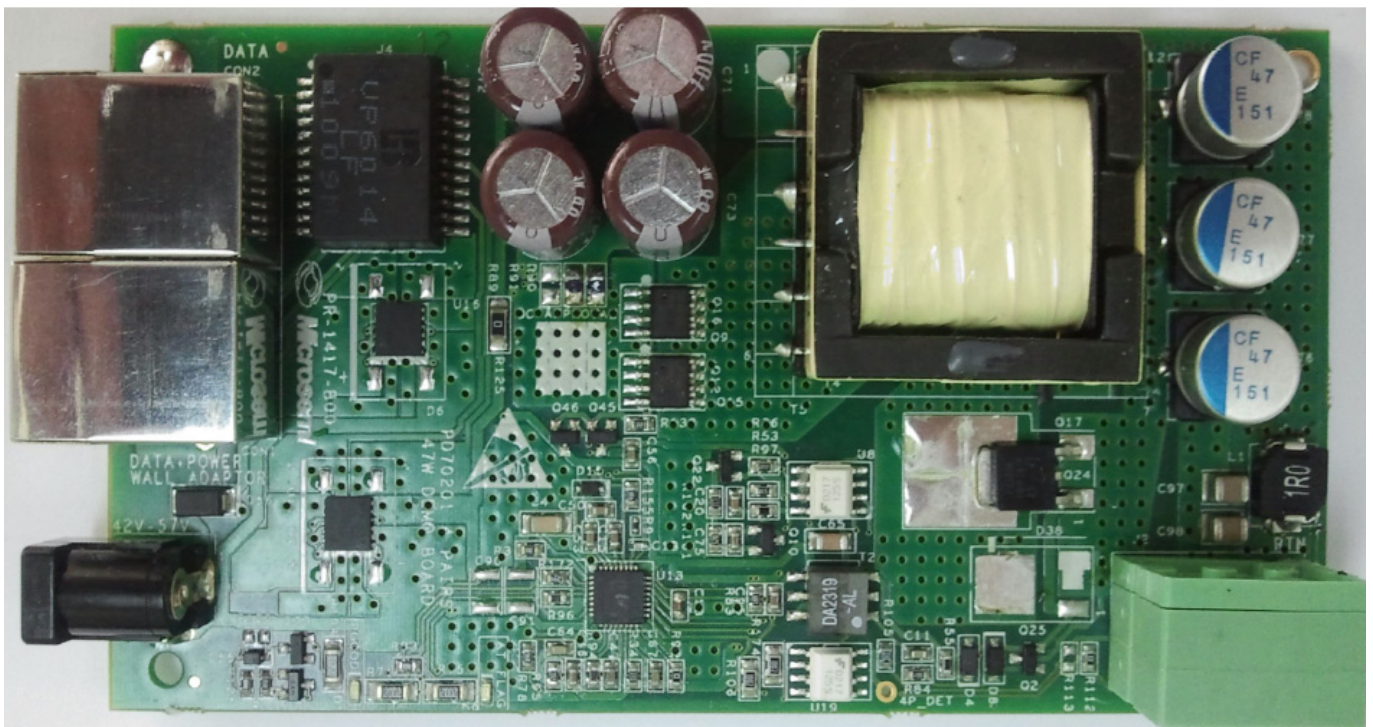

Figure 2: PD70201EVB47F Evaluation Board – General View

Evaluation Boards Ordering Information

Microsemi's supplies the following Evaluation Boards as shown below:

Ordering Number	Description
PD70201EVB47F	IEEE802.3 Type 1 PD based on PD70201 device controlling an isolated flyback converter , having a 12V 4Amp output.

2.1 Evaluation Board Features

- Designed to support Data and Spare current by a single PD70201 device
- Power is supplied through the 4-pairs of the Cat5 cable.
- Two RJ45 connectors (Data and Power In, Data Out)
- Wall adapter – DC in connector
- Output voltage connector.
- On board Power Good LED indicator
- On board AT detected LED indicator
- Pulse transformer for routing the data to PD application to enable full PD evaluation.
- Evaluation Board working temperature: 0° to +70°C
- RoHS compliant

2.2 Evaluation Board Interfaces and Connections

Board has several interfaces:

- **RJ45 Interface:** Running from PSE side to PD (powered device)(CON1)
- **RJ45 Interface:** Running from Evaluation Board to evaluated PD (CON2)

- **V_{in} Connectors:** DC in, alternative wall adapter connection (J3)
- **Output Voltage Connector:** output voltage connection (J2)
- **LEDs Indication:** Power good LED indication (D5)
- **LEDs Indication:** AT flag LED indication (D9)

2.3 Physical Characteristics

Table 1 lists evaluation board's physical characteristics.

Table 1: Physical Characteristics

Parameter	Value
Mechanical dimensions in mm	122 x 65 x 25 mm (L x W x H)

3 Physical Description

3.1 Package Contents

Upon opening the Evaluation Board package, verify the following part is included. If it seems damaged, contact local representative or Microsemi's headquarters.

Package content for standard shipments is:

- PD70201EVB47F Evaluation Board

3.2 Connectors

The following sections provide both general and detailed information regarding unit's connectors.

3.2.1 Connectors Table

Table 2 lists the Evaluation Board's connectors.

Table 2: Connectors List

#	Connector	Name	Description
1	CON1	RJ45 Connector	RJ45 port for Data and Power In for PSE connection
2	CON2	RJ45 Connectors	RJ45 port for Data Out for PD data connection
3	J3	Optional Wall Adapter	Optional DC in connection for powering the board instead of CON1. Insertion of wall adapter connector disconnects CON1.
4	J2	Converter Output	terminal blocks for connecting a load to output regulator

3.2.2 Connectors Detailed Explanation

(The numbering is in reference to the numbers listed in Table 2.)

1. RJ45 Connectors

There are two dedicated RJ45 connectors, See Figure 3.

Table 3: RJ45 Connectors

CON2 Pin No	Signal Name	Description
1, 2, 3, 4, 5, 6, 7, 8	Data Out	Data output to PD
CON1 Pin No	Signal Name	Description
1, 2	Data and Power In	Data and power input to powered device (PoE Master Negative data port)
3, 6	Data and Power In	Data and power input to powered device (PoE Master Positive data port)
4, 5	Data and Power In	Data and power input to powered device (PoE Master Negative data port)
7, 8	Data and Power In	Data and power input to powered device (PoE Master Positive data port)

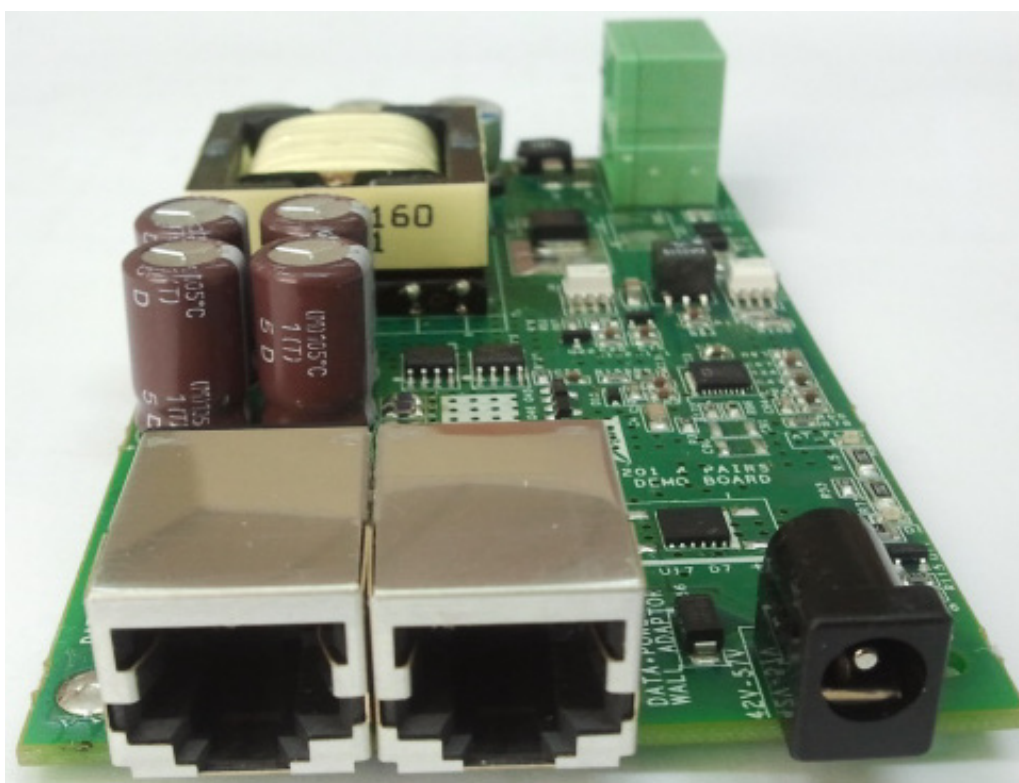

Figure 3: Front RJ45 and Wall Adapter Connectors

2. V_{in} Connectors (J3)

DC in connection can be used to power Evaluation Board instead of RJ45 PSE connection

$42V > V_{in} > 57VDC$.

Table 4: V_{in} Connectors

Pin No.	Signal Name	Description
External ring	$V_{main} (V_{in} -)$	Negative input voltage
Internal pin	$V_{main} (V_{in} +)$	Positive input voltage

- Manufacturer: **TAI CHUNG ELECTRONIC COMPONENT PARTS CO., LTD.**
- Manufacture part number: **TC18-013-02**

3. V_{out} Connectors

See Figure 4.

J2 – DCDC output connection, used for connecting to external load.

Table 5: J1 Connectors

Pin No.	Signal Name	Description
J2 (Left)- Pin 1	Vout	Positive DCDC output voltage
J2 (Right)- Pin 2	Vout_Rtn	Return of DCDC output voltage



Figure 4: V_{out} Connectors

3.3 Indications

The following sections provide general information regarding unit's indications.

1. LED Indication

See Figure 5.

D5 is the Power_GOOD indication LED, a PD70201 device output signal indicating device's isolation switch is operated. The PWM converter should be turned ON only after this signal is active.

D9 is the AT flag indication LED, a PD70201 device output signal indicating device's has detected two fingers class thus PSE side is AT level capable. This signal is an indication to the PD environment that AT power level is supported.



Figure 5: Power_Good LED Indication D5

2. 4P powering Circuitry

See Figure 7.

This circuit intends to indicate to the PD application when the power is supplied on the 4 pairs of Cat5E cable. For IEEE802.3 AT Type 2 compliant interface, each of the 2 pairs can support current up to 600 mA. Thus for supporting the 47 Watt application of the existing board, the current should be supplied by the 4 pairs. The 47 Watt at the DCDC output is maintained only if all of the 4 Pairs are active and powering the PD.

The 4 Pairs active detection is done by the circuit in Figure Figure 6: 4P_DET indication.

When power is supplied on Data pairs (pins 1,2 and 3,6) D31 is conducting on one of its Diode instances, thus asserting Low D33-Pin1.

When power is supplied on Spare pairs (pins 4,5 and 7,8) D32 is conducting on one of its Diode instances, thus asserting Low D33-Pin2.

If the power is supplied both on Data and Spare (thus 4 pairs are supplying Power), D33 is not conducting so Q11 has Low on its Gate and thus U19 LED is not lit and there is High on 4P_DET TP.

If the power is supplied on one of the paths, Data or Spare (thus 2 pairs are supplying Power), D33 is conducting so Q11 has a voltage on its Gate which operates Q11 and thus U19 LED is lit and there is Low on 4P_DET TP.

In Figure 7 you can see the location of 4P_DET TP, Near the J1 output connector. You can use the floating GND named also SLEEPGND or the Vout_RTN signal as the return path for this indication.

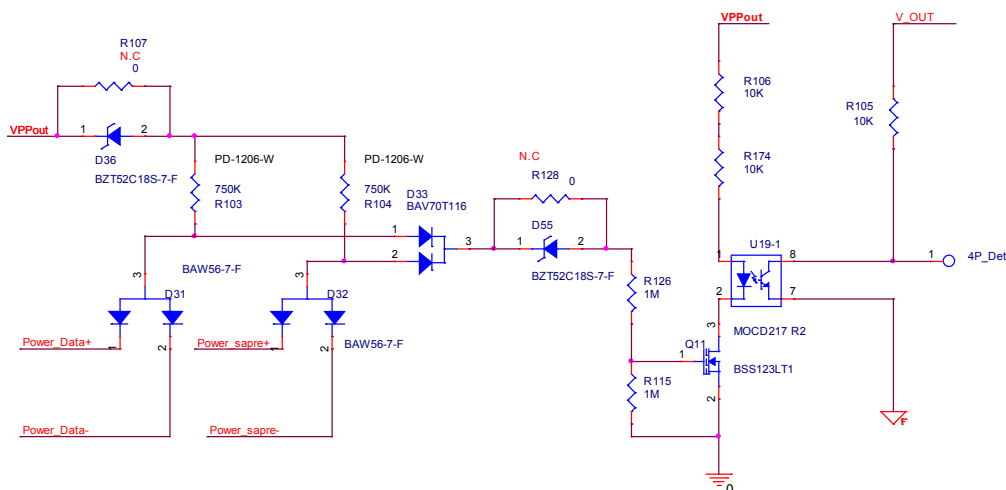

Figure 6: 4P_DET indication Circuit

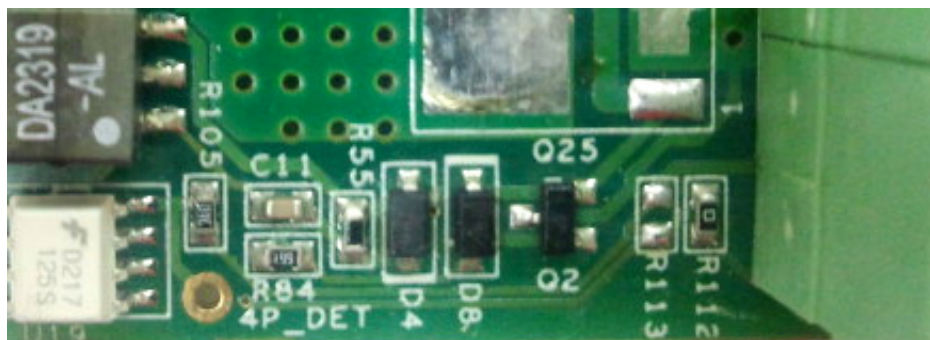

Figure 7: 4P_DET indication Test Point

3.4 Active bridge MOSFET for Diode bridge circuitry

For the PD side 47 watt application, the diode bridge power drop becomes significantly high due to the high current through it.

In this application we are using Fairchild's Active Bridge MOSFET which comprises 4 FET package instead of each discrete diode bridge.

Traditional Diode bridge D6 and D7 are not assembled.

Fairchild's FDMQ8203 application power dissipation is lower than the discrete Diode Bridge.

You can see below the Diode bridge stage. The circuit comprising U16 and its peripheral replaces the D6 device.

The circuit comprising U17 and its peripheral replaces the D7 device.

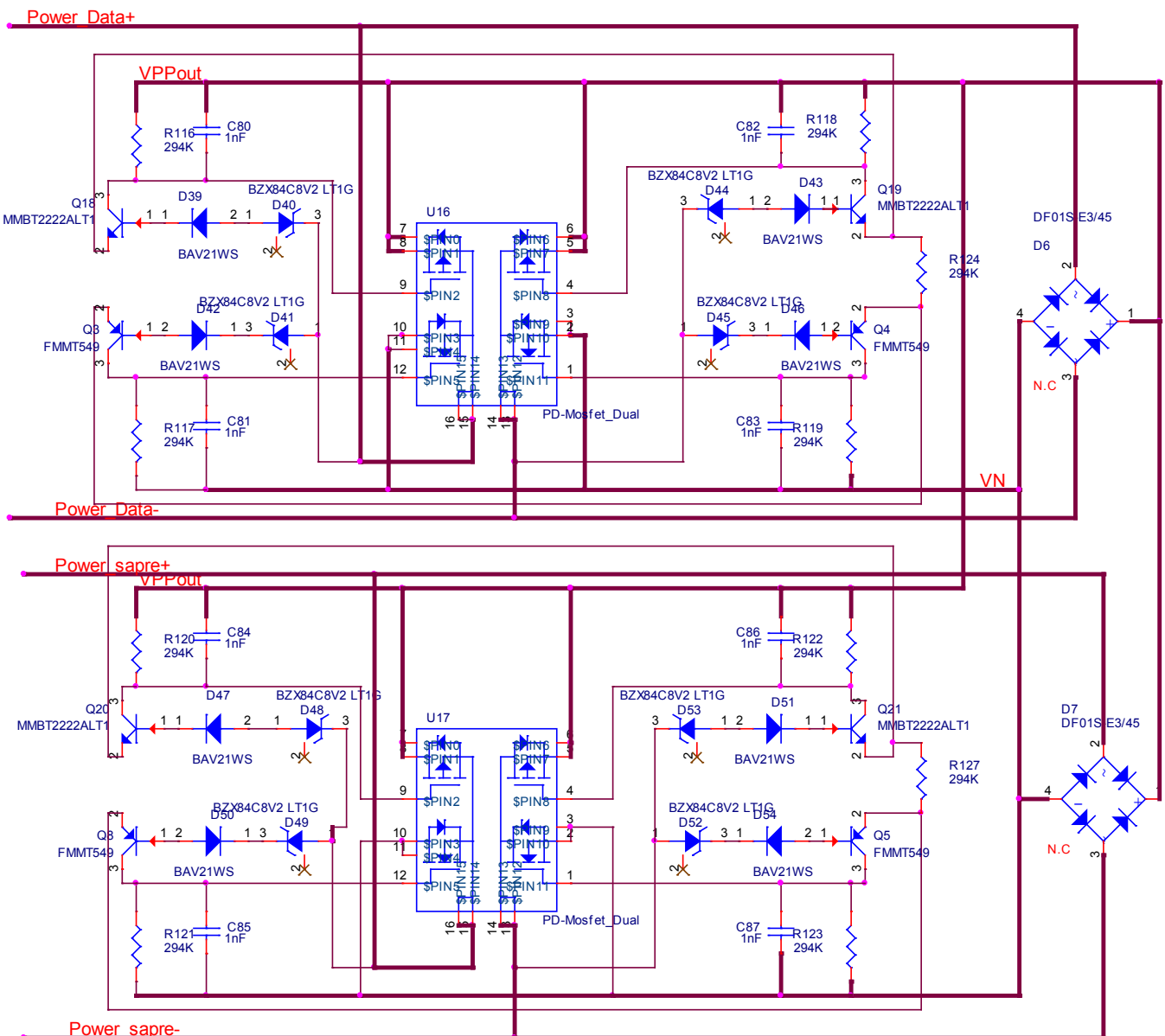

Figure 8: Diode bridge circuitry

4 Electrical Characteristics

Evaluation board's electrical characteristics are described below:

Table 6: Electrical Characteristics

Parameter	Symbol	Min.	Max.	Units
Main DC Supply – Con1, J3		44	57	V
Port Isolation to Chassis		-	1.5	kVrms

5 Installation

This chapter describes the steps required to install and operate Evaluation Board with any PoE application.

All Communication's Isolation to Chassis		-	1.5	kVrms
--	--	---	-----	-------

5.1 Preliminary Considerations and Safety Precautions

- Verify board's power supply is turned on before peripheral devices are turned on.

5.2 Initial Configuration

Note: It is important to verify Evaluation Board is setup as shown in Figure 9 prior to starting any operation.

- Connect load to main board (J1).
- Connect a power cable from power supply to Evaluation Board (CON1).
- Connect Ethernet Cable from Evaluation Board (CON2) to PD Ethernet Host.

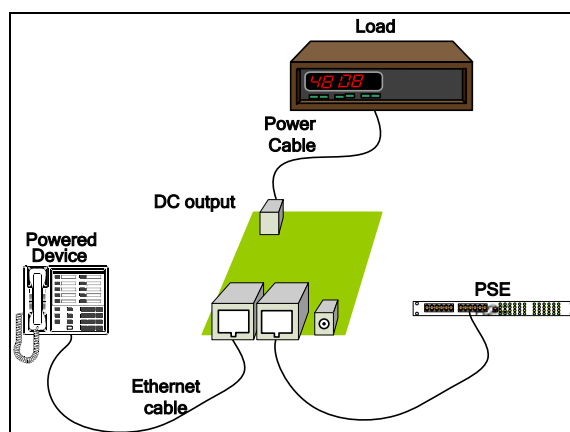
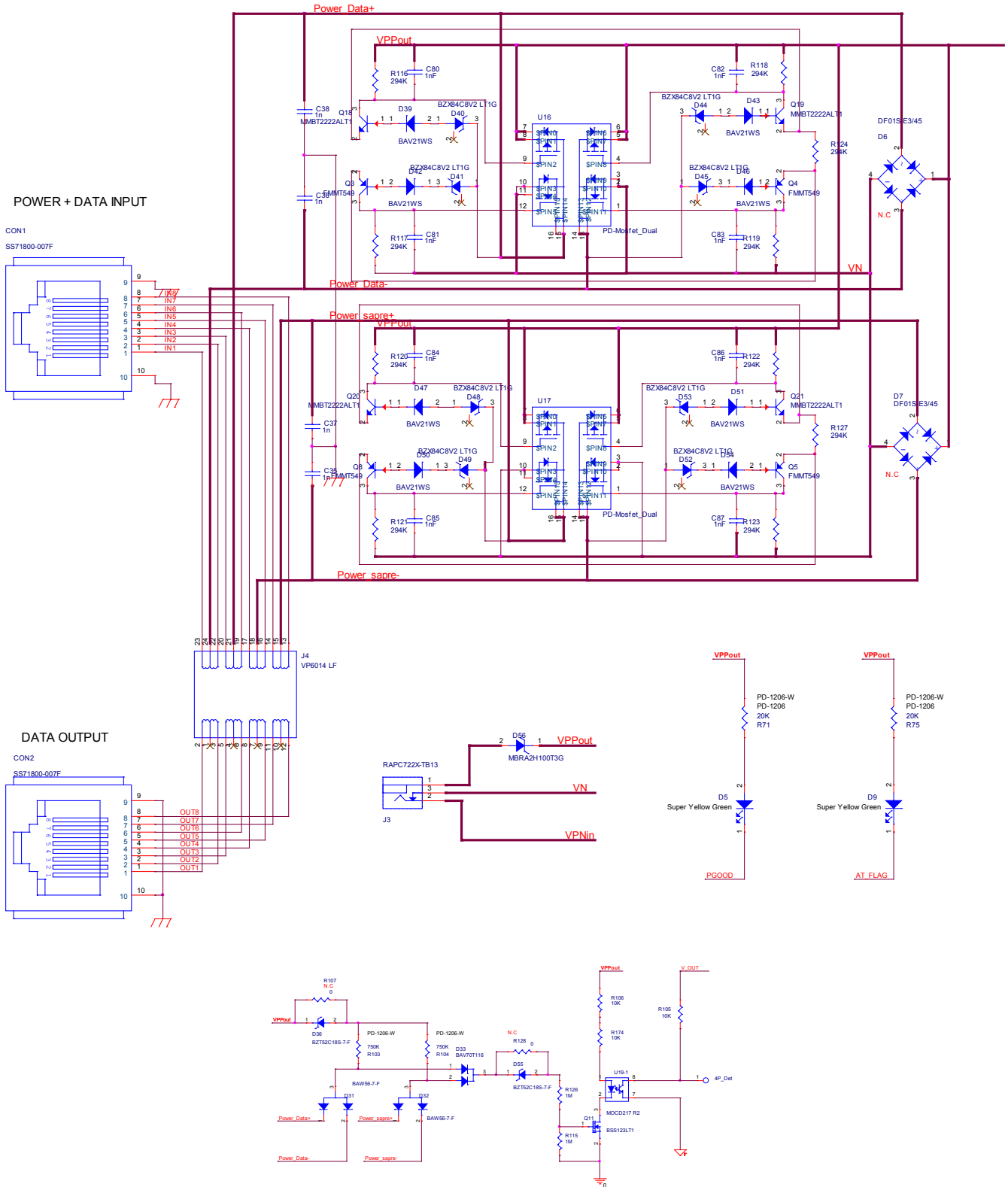

Figure 9: Test Setup

6 Schematic





PD70201EVB47F Evaluation Board – User Guide

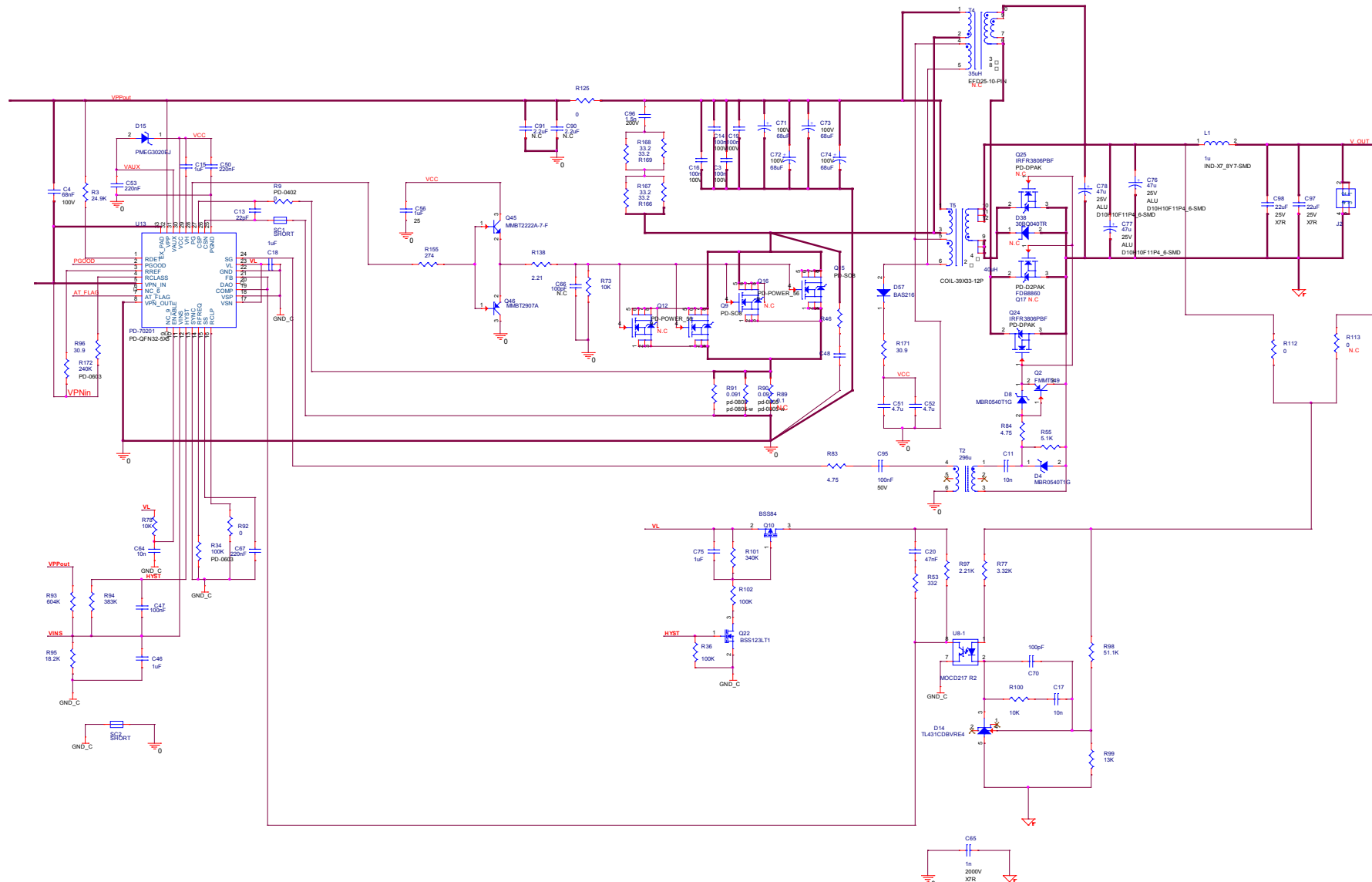



7 List of Materials-

Item	Item Description	Qty	Ref Des	Manufacturer	Manufacture P/N
1	CAP CRM 68nF 100V 10% X7R 1206 SMT	1	C4	AVX	12061C683KAT2A
2	CAP CRM 1nF/2000V 10%+X7R 1206 SMT	5	C35-C38,C65	AVX	1206GC102KAT1A
3	CAP CRM 1.5nF 200V 10% X7R 1206 SMT	1	C96	AVX	12062C152KAT2A
4	CAP CRM 100nF 100V 10% X7R 1206 SMT	4	C3,C14,C16,C19	AVX	12061C104KAT2A
5	CAP CER 22pF 50V 5% NPO 0402 SMT	1	C13	Kemet	C0402C220J5GAC
6	Capacitor, X7R, 4.7uF, 25V, 10% 1210	2	C51,C52	Murata	GRM32DR71E475KA61L
7	CAP CRM 22uF 25V 20% 1210 X7R SMT	2	C97,C98	Murata	GRM32ER71E226ME15L
8	CAP COG 100pF 50V 5% 0603	1	C70	AVX	06035A101JAT2A
9	Cap 1nF 100V 10% X7R 0603 SMT	8	C80-C87	Hitano	0603B102K101NT
10	Capacitor, X7R, 47nF, 16V, 10%	1	C20	Murata	GRM188R71C473KA01
11	CAP CRM 100nF 50v 10% X7R 0603	1	C95	Murata	GRM188R71H104KA01
12	CAP 220NF 25V X7R 10% 0603	3	C50,C53,C67	Murata	GRM188R71E224KA88D
13	Capacitor,X7R, 1uF, 25V, 10% 0603	5	C15,C18,C46,C56,C75	Murata	GRM188R71E105KA12D
14	Capacitor, X7R, 100nF,100v, 10% 0603	1	C47	Murata	GRM188R72A104KA35D
15	CAP CRM 10nF 50v 10% X7R 0603 SMT	3	C11,C17,C64	Murata	GRM188R71H103KA01
16	CAP ALU 47uF 25V 10X10mm ESR=45 Irms=2400 mA SMT	3	C76-C78	Nichicon	PCF1E470MCL1GS
17	CAP ALU 68uF 100V 20% 10x16 IR=600mA 4000 Hr P=5	4	C71-C74	Nippon Chemi-Con	EKZE101ELL680MJ16S
18	CON RJ45 SINGLE 8 POS. SHILDED after vibration	2	CON1,CON2	Bel Stewart	SS71800-007F
19	CON DC POWER JACK RA 2.0X6.3 T/H	1	J3	Shogyo International Corp.	MJ-179P
20	Terminal block 2 pole interlocking 5mm pitch PB C insert	1	J2	DINKLE	DT-123RA-02P
21	Diode Dual C.A 70v 200mA 225mW SOT23 BAW 56	2	D31,D32	Diodes Inc.	BAW56-7-F
22	DIO 200V 250mA SOD323 SMT trr=50nSEC SWI	8	D39,D42,D43,D46,D47,D50,D51,D54	Diodes Inc.	BAV21WS-7-F
23	DIO DUAL 70V 150mA SOT-23 SMT	1	D33	Diodes Inc.	BAV70-7-F
24	DIO 85V 250mA HIGH SPE. SOD110 SMT	1	D57	Philips	BAS216
25	DIO SCHOTTKY 100V 2A SMA SMT	1	D56	ON Semiconductor	MBRA2H100T3G
26	DIO SCHOTTKY 30V 2A SOD323F SMT	1	D15	NXP	PMEG3020EJ
27	DIO SCHOTTKY 40V 500mA SOD123 REC. SMT	2	D4,D8	ON Semiconductor	MBR0540T1G
28	DIO 8.2V 225mW 5% Ir=5uA SOT23 SMT ZENER	8	D40,D41,D44,D45,D48,D49,D52,D53	ON Semiconductor	BZX84C8V2 LT1G
29	Diode Zener, 18V 200mW SOD323	2	D36,D55	Diodes Inc.	BZT52C18S-7-F
30	IC Prog Shunt Ref 2.5V 2% SOT23-5 SMT	1	D14	Philips	TL431CD5



PD70201EVB47F Evaluation Board – User Guide

Item	Item Description	Qty	Ref Des	Manufacturer	Manufacture P\N
31	1000 BASE T SINGLE PORT VOICE OVER IP MAGNETICS MODULE SMT	1	J4	BOTHHAND	VP6014 HF
32	AT POE PD controller for IEEE 802.3 PD70201	1	U13		
33	INDUCTOR SHIELDED PWR 1UH IRMS=11A SMT	1	L1	Bourns	SRP7030-1R0M
34	Flyback Transform 40uH 15% 0.3uH to1.2uH T.H	1	T5	ICE Components Asia Co. Ltd.	TX11160
35	Transformer, Gate driver SMT 269uH 0.795 DCR	1	T2	Coilcraft	DA2319-AL
36	LED SuperYelGrn 100-130o 20-40mcd h=1 0603 SMD	2	D5,D9	Everlight	19-21-SYGC5530E3TR8
37	IC OPTOISOLATOR MOCD217 DUALCHANNEL SMT	2	U8,U19	Fairchild	MOCD217R2-M
38	PCB Mrkt EVB 70201 Combo 4p AT Flyback Drilling	1	PCB	PCB Technologies	PR-1417-B00-PT
39	Res Current Sense 0.091ohm 0805 1/4W 100PPM SMT	2	R90,R91	KOA	UR732ATTD91L0F
40	RES 10K 125mW 1% 0805 SMT Thick Film	2	R106,R174	KOA	RK73H2ATTD1002F
41	Resistor, 0 Ohm, 5%, 1/16W 0402	1	R9	ASJ	CR10-000ZK
42	RES 0R 250mW 5% 1206 SMT JUMPER<0.05R	1	R125	Samsung	RC3216J000CS
43	RES 33.2R 250mW 1% 1206 SMT MTL FLM	4	R166-R169	Bourns	CR1206-FX-33R2-ELF
44	RES TK FLM 20K 250mW 1% 1206	2	R71,R75	Bourns	CR1206-FX-2002-ELF
45	RES 750K 250mW 1% 1206	2	R103,R104	Samsung	RC3216F7503CS
46	RES TCK FLM 0R 62.5mW 5% 0603 SMT	2	R92,R112	ASJ	CR16-000ZL
47	RES TCK FLM 24.9K 62.5mW 1% 0603 SMT	1	R3	ASJ	CR16-2492FL
48	RES 383K 100mW 1% 0603SMT MTL FLM	1	R94	ASJ	CR16-3833FL
49	Resistor, 3.32K, 1%, 1/16W 0603	1	R77	ASJ	CR16-3321FL
50	Resistor, 13K, 1%, 1/16W 0603	1	R99	ASJ	CR16-1302FL
51	Resistor, 30.9R 1%, 1/10W 0603	2	R96,R171	KOA	RK73H1JTDD30R9F
52	Resistor, 294K, 1%, 1/16W 0603	10	R116-R124,R127	ASJ	CR16-2943FL
53	Resistor, 2.21K, 1%, 1/16W 0603	1	R97	ASJ	CR16-2211FL
54	RES TCK FLM 5.1K 62.5mW 1% 0603 SMT	1	R55	ASJ	CR16-5101FL
55	RES 604K, 1%, 1/16W, 0603	1	R93	ASJ	CR16-6043FL
56	Resistor, 240K, 1%, 1/10W 0603	1	R172	KOA	RK73H1JTDD2403F
57	RES 2.21R 62.5mW 1% 0603 SMT MTL FLM	1	R138	ASJ	CR16-2R21FL
58	RES 4.75R 0.1W 1% 0603 SMT MTL FLM	2	R83,R84	Samsung	RC1608F4R75CS
59	RES TCK FLM 274R 62.5mW 1% 0603 SMT	1	R155	Bourns	CR-0603-FX-2740ELF
60	RES 332R 62.5mW 1% 0603 SMT MTL FLM	1	R53	ASJ	CR16-3320FL
61	RES 10K 62.5mW 1% 0603 SMT MTL FLM	4	R73,R78,R100,R105	ASJ	CR16-1002FL
62	RES 18.2K 62.5mW 1% 0603 SMT MTL FLM	1	R95	Rohm	MCR03EZHF1822
63	RES 51.1K 62.5mW 1% 0603 SMT MTL FLM	1	R98	ASJ	CR16-5112FL
64	RES 100K 62.5mW 1% 0603 SMT MTL FLM	3	R34,R36,R102	ASJ	CR16-1003FL
65	RES TN FLM 340K 1% 62.5mW 0603 SMT	1	R101	ASJ	CR16-3403FL
66	RES 1M 62.5mW 1% 0603 SMT MTL FLM	2	R115,R126	ASJ	CR16-1004-FL
67	TRN PNP -30V -1A SOT23	5	Q2-Q5,Q8	Fairchild	FMMT549



PD70201EVB47F Evaluation Board – User Guide

Item	Item Description	Qty	Ref Des	Manufacturer	Manufacture P\N
68	TRN NPN 40V 600mA SOT23 300mW 250MHZ MMBT2222	5	Q18-Q21,Q45	Diodes Inc.	MMBT2222A-7-F
69	TRN PNP 60V 600mA SOT23 SMT 250mW	1	Q46	Fairchild	KST2907AMTF_NL
70	FET PCH -50V -0.13A 10R ENH MODE SOT-23	1	Q10	Fairchild	BSS84
71	FET NCH 100V 0.15A 6R Logic Level SOT23	2	Q11,Q22	Diodes Inc.	BSS123-7-F
72	IC Dual N/P CH power mosfet 100v 6A SMT	2	U16,U17	Fairchild	FDMQ8203
73	N-CH POWER MOSFET DPAK 60V 43A 18mOhm	1	Q24	I.R.	IRFR3806PBF
74	MOSFET N-CH 200V 3.9A 8-SOIC SMT	2	Q9,Q15	Fairchild	FDS2672



The information contained in the document is PROPRIETARY AND CONFIDENTIAL information of Microsemi and cannot be copied, published, uploaded, posted, transmitted, distributed or disclosed or used without the express duly signed written consent of Microsemi. If the recipient of this document has entered into a disclosure agreement with Microsemi, then the terms of such Agreement will also apply. This document and the information contained herein may not be modified, by any person other than authorized personnel of Microsemi. No license under any patent, copyright, trade secret or other intellectual property right is granted to or conferred upon you by disclosure or delivery of the information, either expressly, by implication, inducement, estoppels or otherwise. Any license under such intellectual property rights must be approved by Microsemi in writing signed by an officer of Microsemi.

Microsemi reserves the right to change the configuration, functionality and performance of its products at anytime without any notice. This product has been subject to limited testing and should not be used in conjunction with life-support or other mission-critical equipment or applications. Microsemi assumes no liability whatsoever, and Microsemi disclaims any express or implied warranty, relating to sale and/or use of Microsemi products including liability or warranties relating to fitness for a particular purpose, merchantability, or infringement of any patent, copyright or other intellectual property right. The product is subject to other terms and conditions which can be located on the web at <http://www.microsemi.com/legal/tnc.asp>

Revision History

Revision Level / Date	Para. Affected/Page	Description
0.1 / 11-Dec-11		Initial revision
0.2 / 18-Mar-11		Update Revision B of the board

© 2011 Microsemi Corp.

All rights reserved.

For support contact: sales_AMSG@microsemi.com

Visit our web site at: www.microsemi.com

Catalog Number: PD70201_47F_UG_EVB

Данный компонент на территории Российской Федерации

Вы можете приобрести в компании MosChip.

Для оперативного оформления запроса Вам необходимо перейти по данной ссылке:

<http://moschip.ru/get-element>

Вы можете разместить у нас заказ для любого Вашего проекта, будь то серийное производство или разработка единичного прибора.

В нашем ассортименте представлены ведущие мировые производители активных и пассивных электронных компонентов.

Нашей специализацией является поставка электронной компонентной базы двойного назначения, продукции таких производителей как XILINX, Intel (ex.ALTERA), Vicor, Microchip, Texas Instruments, Analog Devices, Mini-Circuits, Amphenol, Glenair.

Сотрудничество с глобальными дистрибьюторами электронных компонентов, предоставляет возможность заказывать и получать с международных складов практически любой перечень компонентов в оптимальные для Вас сроки.

На всех этапах разработки и производства наши партнеры могут получить квалифицированную поддержку опытных инженеров.

Система менеджмента качества компании отвечает требованиям в соответствии с ГОСТ Р ИСО 9001, ГОСТ РВ 0015-002 и ЭС РД 009

Офис по работе с юридическими лицами:

105318, г.Москва, ул.Щербаковская д.3, офис 1107, 1118, ДЦ «Щербаковский»

Телефон: +7 495 668-12-70 (многоканальный)

Факс: +7 495 668-12-70 (доб.304)

E-mail: info@moschip.ru

Skype отдела продаж:

moschip.ru

moschip.ru_4

moschip.ru_6

moschip.ru_9