

VS-04-2X2X26C7/7-67B/SDA/2,0

Order No.: 1653919

<http://eshop.phoenixcontact.de/phoenix/treeViewClick.do?UID=1653919>

Assembled USB cable, shielded, color: RAL 5021 (water blue), PUR
outer sheath, USB type B/IP67 on USB type A/standard, length: 2 m

Commercial data

GTIN (EAN)	 4 017918 970246
sales group	D532
Pack	1 pcs.
Customs tariff	85444290
Catalog page information	Page 311 (PC-2009)

Product notes

WEEE/RoHS-compliant since:
08/29/2006



[http://
www.download.phoenixcontact.com](http://www.download.phoenixcontact.com)
Please note that the data given
here has been taken from the
online catalog. For comprehensive
information and data, please refer
to the user documentation. The
General Terms and Conditions of
Use apply to Internet downloads.

Technical data**Mechanical characteristics**

Number of positions	4
Shielded	Yes
Insertion/withdrawal cycles	≥ 500
External cable diameter	6.7 mm
Cable diameter	6.70 mm

Cable structure	2x2xAWG26/7 + 2xAWG20/19; S/FTP
Length of cable	2 m
Ambient temperature (operation)	-20 °C ... 60 °C (cable, fixed installation)
	0 °C ... 50 °C (cable, flexible installation)
	(Male connector / female connector)

Material data

Housing material	PA
Sealing material	NBR
Material, O-ring	FPM
Outer sheath, material	PUR
External sheath, color	water blue RAL 5021
Degree of protection	IP67/IP20

Electrical characteristics

Rated voltage (III/3)	125 V
Rated current	1 A
Transmission characteristics (category)	USB 2.0

Line characteristics

Cable type	FireWire
Conductor cross section	0.14 mm ² (signal line)
	0.5 mm ² (Power supply)
AWG signal line	26
Conductor structure signal line	7x 0.15 mm
AWG power supply	20
Conductor structure, voltage supply	19x 0.20 mm
Core diameter including insulation	1 mm (signal line)
External cable diameter	6.70 mm
Wire colors	White-blue, white-orange, gray, black
External sheath, color	water blue RAL 5021
Insulation resistance	5 GΩ*km
Conductor resistance	150 mΩ/m
Transmission characteristics (category)	CAT7, for USB 2.0 (480 Mbps)
Working capacitance	42 pF
Wave impedance	100 Ω ±5% (signal line)
Signal speed	0.72 c

Signal runtime	46 ns/m
Shield attenuation	60 dB (Up to 1000 MHz)
Interference suppression	90 dB (Up to 1000 MHz)
Nominal voltage, conductor	125 V
Test voltage, conductor	1000 V
Twisted pairs	2 cores to the pair
Type of pair shielding	Aluminum-lined polyester foil
Overall twist	Two pairs and two power supply wires to the core
Shielding	Braided shielding made of galvanized copper wires
Optical shield covering	65 %
Outer sheath, material	PUR
Material conductor insulation	Cell PE (signal line)
	PVC (Power supply)
Conductor material	Bare Cu litz wires
Cable weight	56 kg/km
Smallest bending radius, fixed installation	≥ 35 mm
Smallest bending radius, movable installation	≥ 35 mm
Ambient temperature (operation)	-20 °C ... 60 °C (cable, fixed installation)
	0 °C ... 50 °C (cable, flexible installation)

Accessories

Item	Designation	Description
Marking		
0814775	VS-ZBFM-8-SET	Marker label set, consisting of 4 sheets (white, blue, yellow, orange) each with 50 labels for color marking of sleeve housings and panel mounting frames with IP67 protection
Protective covers		
1653757	VS-SCRJ-PC	IP67 protective cover, for covering the male inserts in the sleeve housings IP67, VS-SCRJ-..., VS-04-..., VS-06-... and VS-08-...

Diagrams/Drawings

Dimensioned drawing

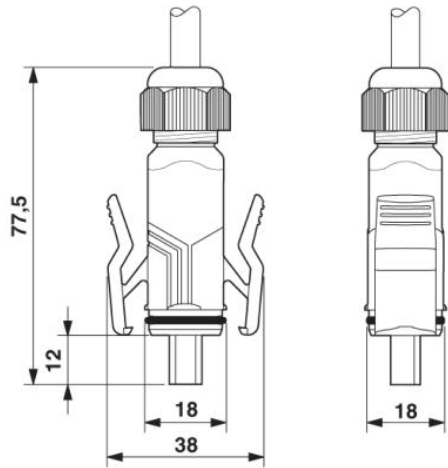

USB connector, type B, IP67

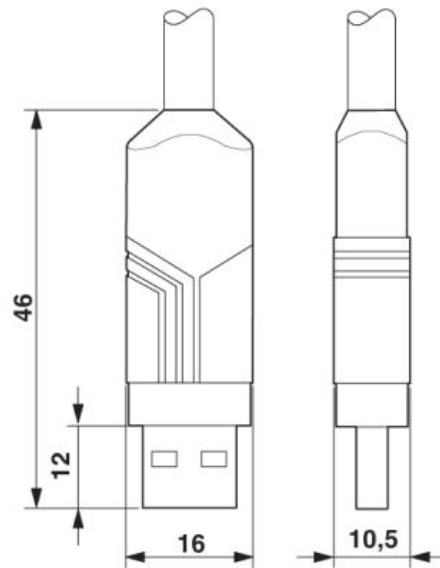

USB plug connector, type A, Standard

Circuit diagram

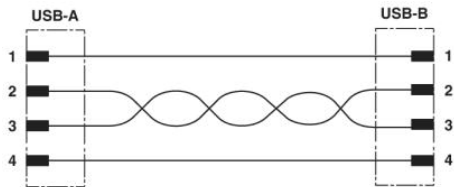

Schematic diagram

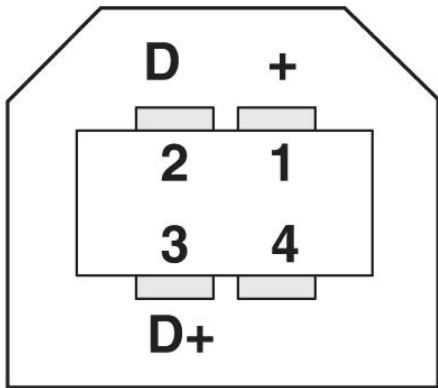

Connector pin assignment plug USB, type B

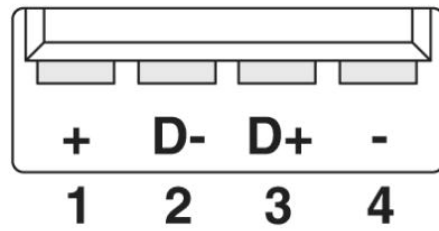

Pin assignment plug USB, type A

Address

PHOENIX CONTACT Deutschland GmbH
Flachmarktstr. 8
32825 Blomberg, Germany
Phone +49 5235 3 12000
Fax +49 5235 3 41200
<http://www.phoenixcontact.de>



© 2011 Phoenix Contact
Technical modifications reserved;

Данный компонент на территории Российской Федерации

Вы можете приобрести в компании MosChip.

Для оперативного оформления запроса Вам необходимо перейти по данной ссылке:

<http://moschip.ru/get-element>

Вы можете разместить у нас заказ для любого Вашего проекта, будь то серийное производство или разработка единичного прибора.

В нашем ассортименте представлены ведущие мировые производители активных и пассивных электронных компонентов.

Нашей специализацией является поставка электронной компонентной базы двойного назначения, продукции таких производителей как XILINX, Intel (ex.ALTERA), Vicor, Microchip, Texas Instruments, Analog Devices, Mini-Circuits, Amphenol, Glenair.

Сотрудничество с глобальными дистрибьюторами электронных компонентов, предоставляет возможность заказывать и получать с международных складов практически любой перечень компонентов в оптимальные для Вас сроки.

На всех этапах разработки и производства наши партнеры могут получить квалифицированную поддержку опытных инженеров.

Система менеджмента качества компании отвечает требованиям в соответствии с ГОСТ Р ИСО 9001, ГОСТ РВ 0015-002 и ЭС РД 009

Офис по работе с юридическими лицами:

105318, г.Москва, ул.Щербаковская д.3, офис 1107, 1118, ДЦ «Щербаковский»

Телефон: +7 495 668-12-70 (многоканальный)

Факс: +7 495 668-12-70 (доб.304)

E-mail: info@moschip.ru

Skype отдела продаж:

moschip.ru

moschip.ru_4

moschip.ru_6

moschip.ru_9