

M series

Miniature resistive joysticks

Distinctive features and specifications



- World's #1 selling joystick for CCTV applications
- Potentiometric sensing
- One, two or three axis
- Low profile design with 17 handle options
- RoHS

MECHANICAL (FOR X AND Y AXIS)

- Break Out Force: 0.7N (0.16lbf)
- Operating Force: 1.3N (0.29lbf)
- Maximum Applied Force: 100N (22.48lbf)
- Mechanical Angle of Movement: 56°
- Expected Life: See potentiometer options
- Mass/weight: Varies
- Package Size (mm) (L x W x H) or (Dia x H): Varies
- Lever Action (Centering): Spring or Friction

MECHANICAL (FOR Z AXIS)

- Break Out Torque: 0.022N·m (0.19lbf-in)
- Operating Torque: 0.040N·m (0.35lbf-in)
- Maximum Allowable Torque: 0.049N·m (0.43lbf-in)
- Mechanical Angle: 90°
- Handle Action: Spring

ENVIRONMENTAL

- Operating Temperature: -25°C to 70°C (-13°F to 158°F)
- Storage Temperature: -40°C to 70°C (-40°F to 158°F)

POTENTIOMETER OPTIONS

Potentiometer	P	M	R
Electrical Element	Conductive Plastic	Conductive Plastic	Conductive Plastic
Track Resistance	5K	5K	5K
Linearity	±1.0%	±5.0%	±1.0%
Track Operating Angle	220°	56°	50°
CRV	±1.5%	±1.5%	±1.0%
Power Dissipation	0.25W@40°C	0.5W@70°C	1W
Rotational Life	1,000,000	1,000,000	10,000,000

CENTERING OPTIONS

- **SPRING CENTERING:** The joystick returns to center when the handle is released.
- **TORQUE SET:** Torque set provides absolute positioning with uniform friction applied to "X" and "Y" axis.

- NOTES:
- All values are nominal.
 - Specifications are subject to the joystick configuration.
Contact Technical Support for the performance of your specific configuration.
 - The M Series is intended for internal applications.

Note: The company reserves the right to change specifications without notice.

M series

Miniature resistive joysticks

Overview

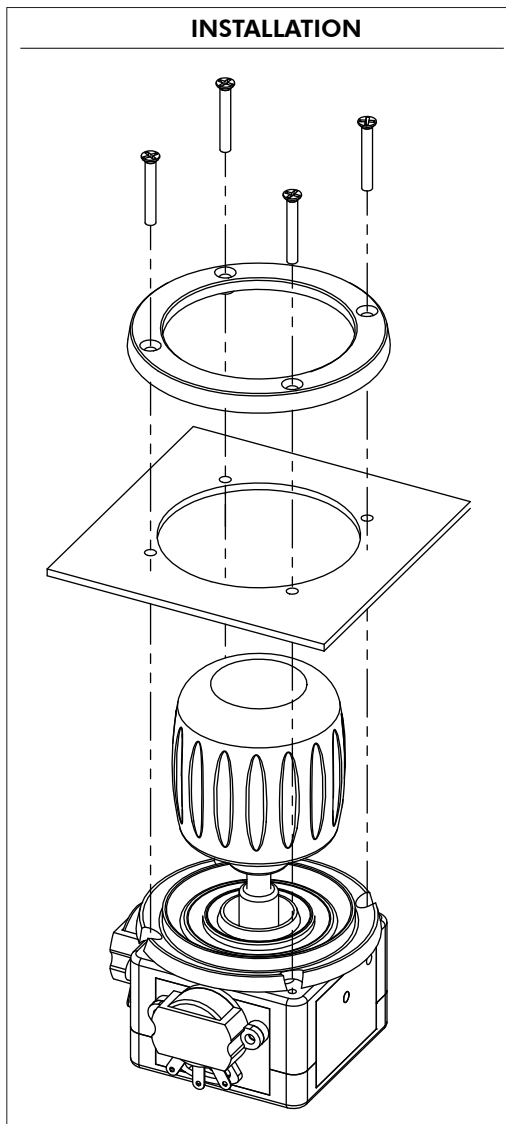
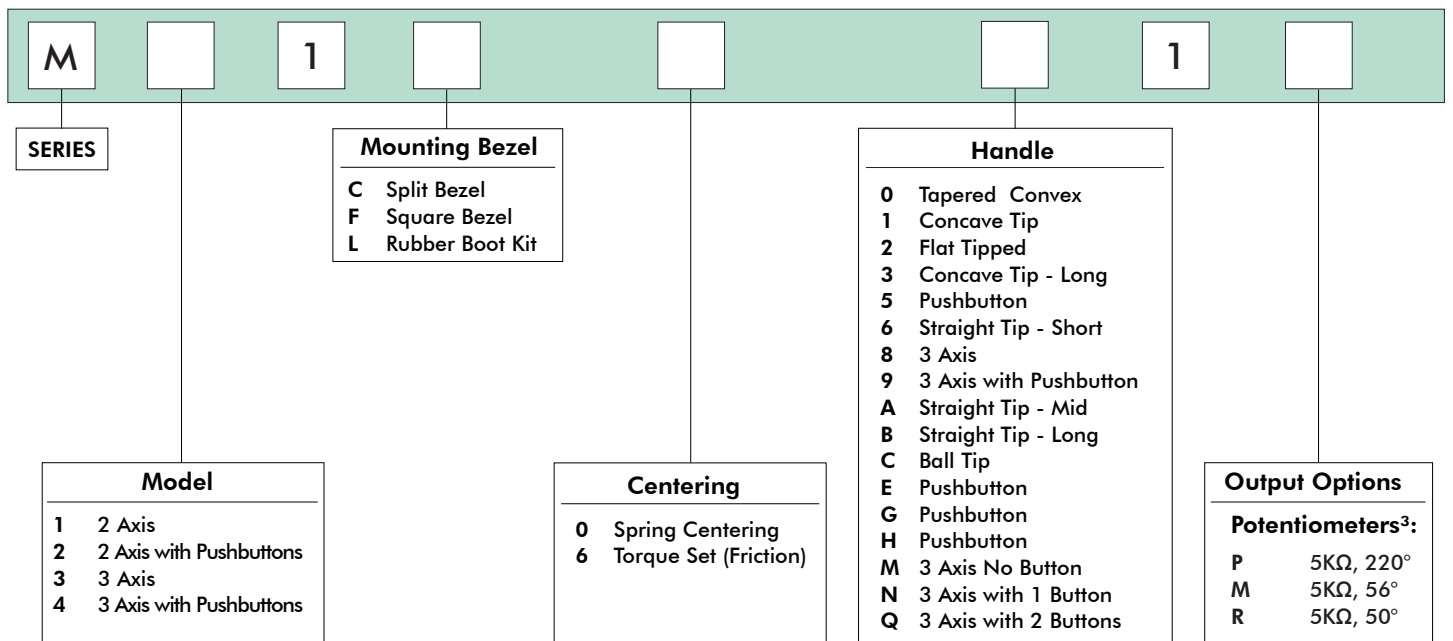

NOTES:

1. Front Mounting Bezels (FM)

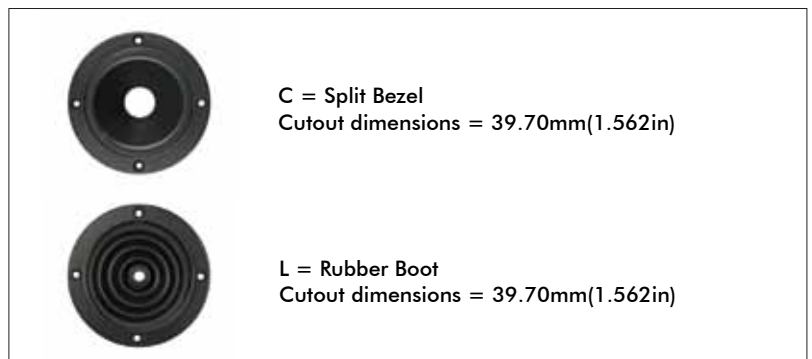

2. Rear mounting bezels (RM)

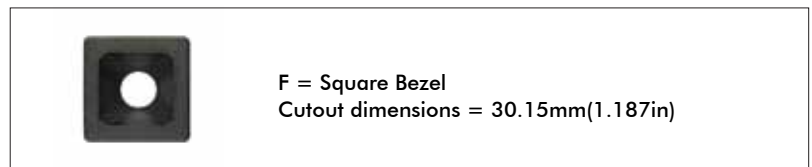

3. Potentiometer specifications are located on the previous page.



Mounting accessories.

Standard hardware includes:

C= Ring, cup, and 4 black Phl screws 2-56x1/2in

L= Ring and 4 black Phl screws 2-56x1/2in

F= Square bezel, 4 screws 2-56x1/2in Phl, and 4 screws 2-56x1/4in Phl

Note: The company reserves the right to change specifications without notice.

M series

Miniature resistive joysticks

Overview

2 AXIS WITH OPTION A HANDLE

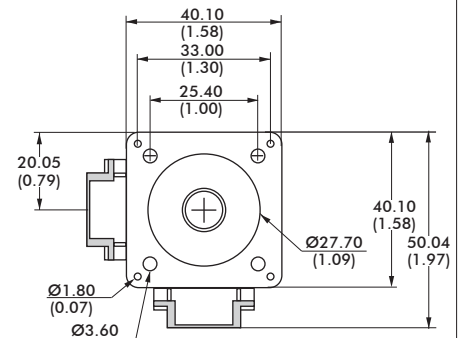
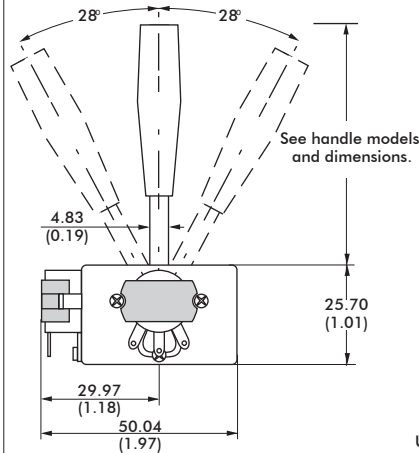

Used for Rear Mount "Square bezel"

NOTES:

1. Mechanical dimensions represent a joystick with the largest potentiometer option.
2. Potentiometer size will vary according to selected option.

HANDLES

2 AXIS

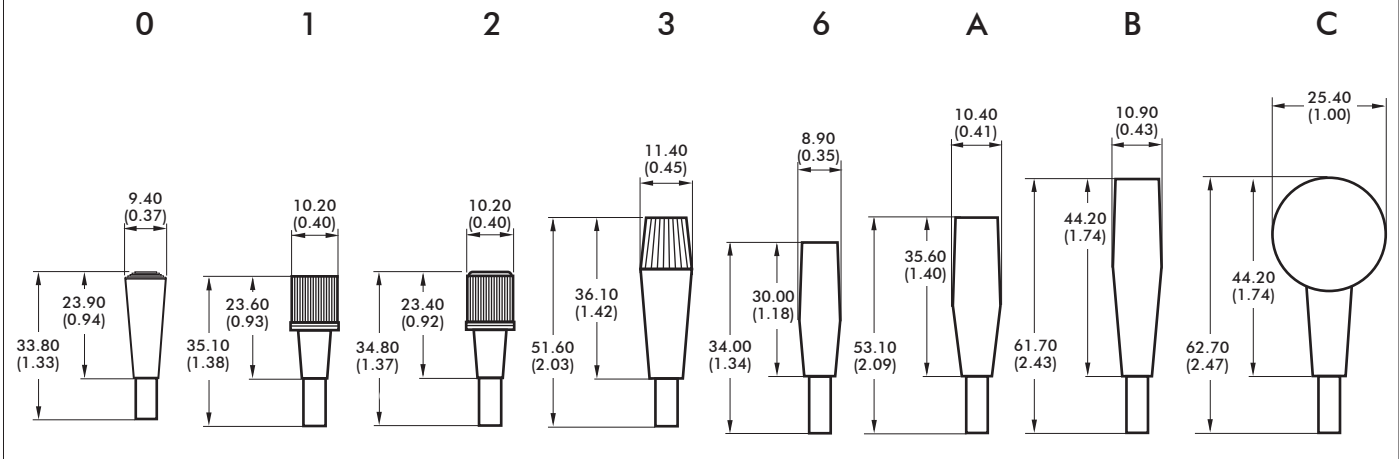

2 AXIS WITH PUSHBUTTON¹

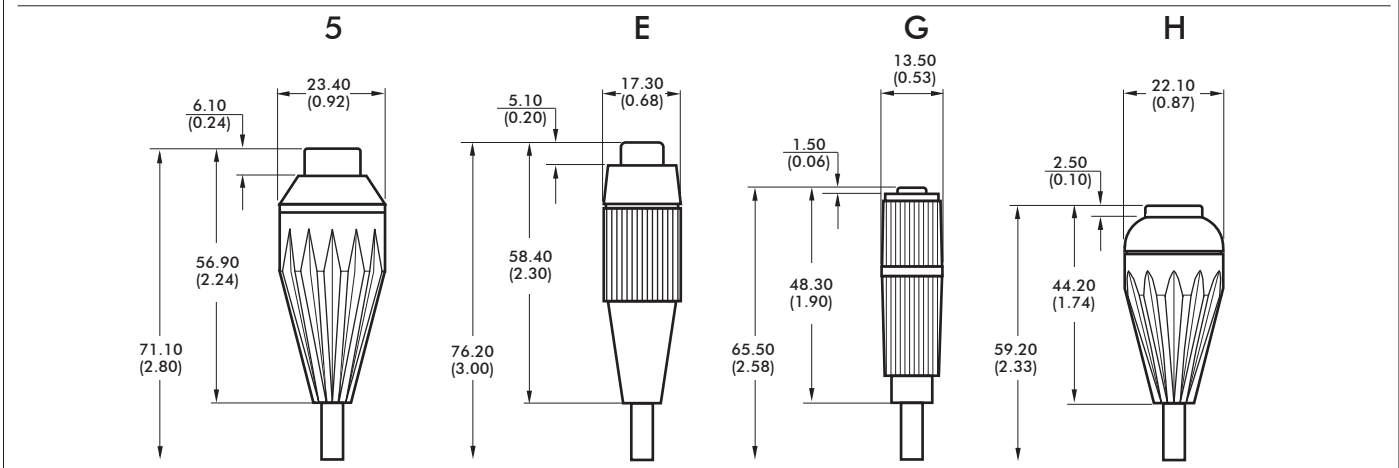

NOTES:

1. Pushbuttons are not sealed. Joysticks are intended for internal applications only.
2. Dimensions are in mm/(inch).

Note: The company reserves the right to change specifications without notice.

M series

Miniature resistive joysticks

Overview

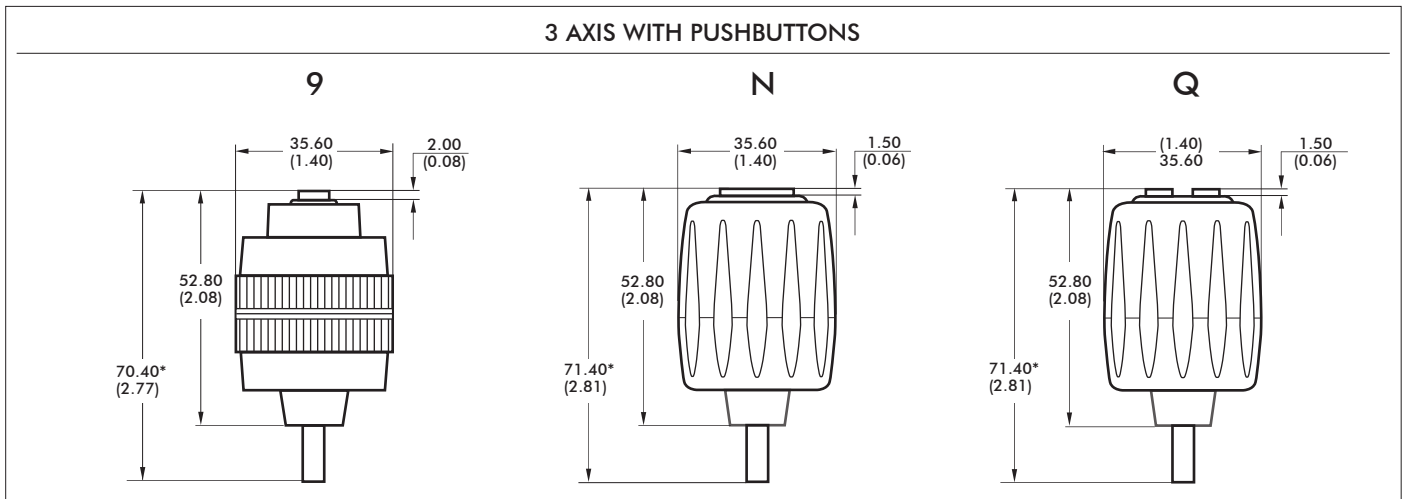
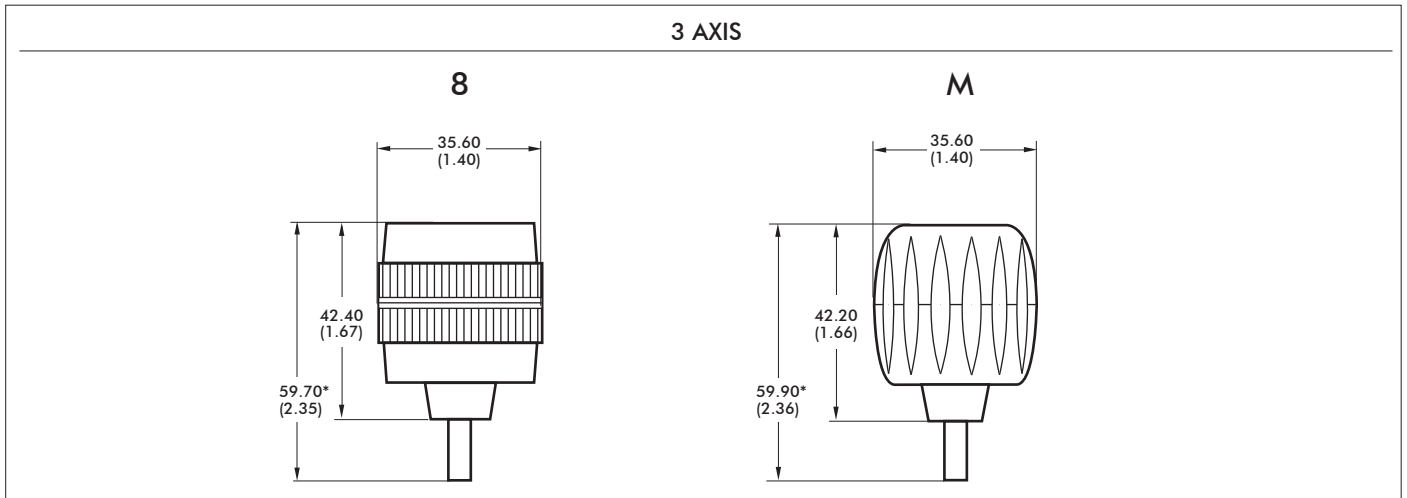

NOTES:

1. Dimensions are in mm/(inch).
2. Pushbuttons are not sealed. Joysticks are intended for internal applications only.
3. Axis orientation:

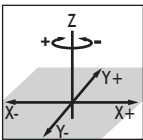
4. Wiring information:
 - Cables are provided for pushbuttons and the Z axis.
 - Cables are not supplied for the potentiometers (axis X and Y).

DEFAULT WIRE COLOR CODE*		
COLOR	FUNCTION	AWG
2 OR 3 AXIS JOYSTICK WITH 1 PUSHBUTTON - OPTIONS 5,E,G,H,9,N		
ORANGE	Switch 1	28
ORANGE	Switch Common	
3 AXIS JOYSTICK WITH 2 PUSHBUTTONS - Option Q**		
ORANGE	Switch 1	28
BROWN	Switch 2	
GREEN	Switch Common	
Z AXIS IN A 3 AXIS JOYSTICK - OPTIONS 8,9,M,N,Q		
RED	Supply	28
WHITE	Signal	
BLUE	Return	

NOTES: * Wires for the Z axis and for the pushbuttons are 292mm (11.5in) and stripped.

** Handle "Q" pushbuttons are shown in the following drawing:

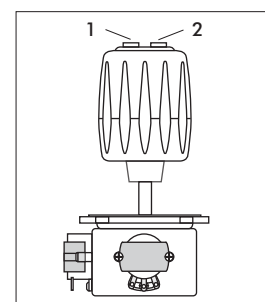

Note: The company reserves the right to change specifications without notice.

Данный компонент на территории Российской Федерации

Вы можете приобрести в компании MosChip.

Для оперативного оформления запроса Вам необходимо перейти по данной ссылке:

<http://moschip.ru/get-element>

Вы можете разместить у нас заказ для любого Вашего проекта, будь то серийное производство или разработка единичного прибора.

В нашем ассортименте представлены ведущие мировые производители активных и пассивных электронных компонентов.

Нашей специализацией является поставка электронной компонентной базы двойного назначения, продукции таких производителей как XILINX, Intel (ex.ALTERA), Vicor, Microchip, Texas Instruments, Analog Devices, Mini-Circuits, Amphenol, Glenair.

Сотрудничество с глобальными дистрибьюторами электронных компонентов, предоставляет возможность заказывать и получать с международных складов практически любой перечень компонентов в оптимальные для Вас сроки.

На всех этапах разработки и производства наши партнеры могут получить квалифицированную поддержку опытных инженеров.

Система менеджмента качества компании отвечает требованиям в соответствии с ГОСТ Р ИСО 9001, ГОСТ РВ 0015-002 и ЭС РД 009

Офис по работе с юридическими лицами:

105318, г.Москва, ул.Щербаковская д.3, офис 1107, 1118, ДЦ «Щербаковский»

Телефон: +7 495 668-12-70 (многоканальный)

Факс: +7 495 668-12-70 (доб.304)

E-mail: info@moschip.ru

Skype отдела продаж:

moschip.ru

moschip.ru_4

moschip.ru_6

moschip.ru_9