

IP54 General Purpose Enclosures

Technical Specification

Manufactured from ADC12 aluminium, this range offers a versatile, IP54 enclosure solution for applications where light protection against dust and low pressure water spray is required.

15 sizes are available, complete with captive screws, earth screws and PCB guides on selected sizes. Nine sizes are also available with flanges for easy mounting.

Deltron Enclosures can customise any enclosure in our UK factory, including machining, painting, component sourcing and installation to meet your specification, save time and cut your costs. View our Services page on our website for more information.



For more information:

Phone: +44 (0)1724 273206

Features:

- IP54 Rated
- Manufactured from ADC12
- Certified to BS EN 60529:1992
- RoHS Compliant

Typical Applications:

- Remote Control Systems
- Keyboards
- Display Boards
- Radio Instrumentation

Available Dimensions (mm):

90 x 36 x 30*	115 x 64 x 30*
115 x 90 x 55*	115 x 65 x 55*
172 x 121 x 55*	172 x 121 x 106*
223 x 147 x 55*	223 x 147 x 106
275 x 176 x 65	141 x 102 x 76
166 x 128 x 76	121 x 101 x 35*
251 x 251 x 99	81 x 56 x 25
61 x 56 x 30	*= Available with Flanges

Finishes: Plain Aluminium, Powder or Nylon coat.

Coating Colours: Grey, Blue or Black.

Or choose to have your enclosure customised for bespoke finishes and colours.

DEM Manufacturing

Deltron Emcon House,
Hargreaves Way,
Sawcliffe Industrial Park,
Scunthorpe, DN15 8RF.

DELTRON Enclosures

Web: www.dem-uk.com/deltron-enclosures

Tel: +44 (0) 1724 273206

Fax: +44 (0) 1724 280353

Email: sales@dem-uk.com

REV	DATE	ECN NUMBER	ECR COMMENT
005	06 Jun 2017	C03614	BORDER CHANGE
004	06 Jun 2017	C03614	TORQUE SETTINGS ADDED

LENGTH	WIDTH	HEIGHT	SEAL	TORQUE SETTINGS	PLAIN	POWDER COAT	NYLON COAT
223	147	106	NONE	NONE	459-0080	461-0080*	462-0080*
			IP66	0.3Nm	460-0080	453-0080*	454-0080*
			IP68	0.7Nm	480-0080	481-0080*	482-0080*
			IP68 EMI/RFI	1.0Nm	480-C080	481-C080*	482-C080*
BOX DIMENSION IN MM			COLOUR OPTION - COLOUR SUFFIX * GREY=A / BLUE=B / BLACK = E				

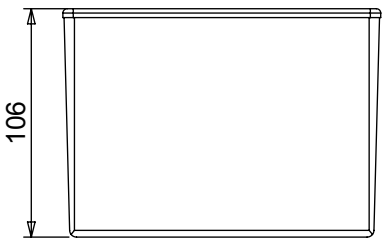
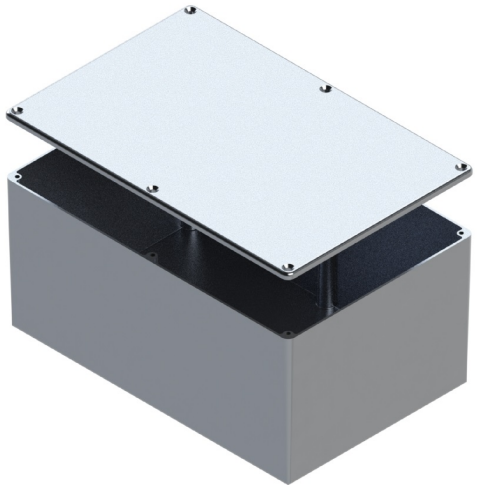

STANDARD DUTY ENCLOSURE

- Material grade ADC12/LM2 Die Cast Alloy
- IP Rated available
- Min wall thickness 1.5mm
- Min lid thickness 1.5mm
- Fine textured powder coating and smooth nylon
- Screws stainless steel
- IP68 Tested to 5 metres for 1 hour
- Enclosures can be supplied fully factory customised to your specification

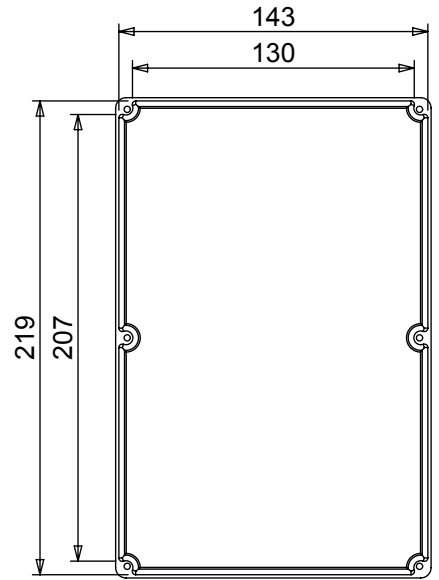
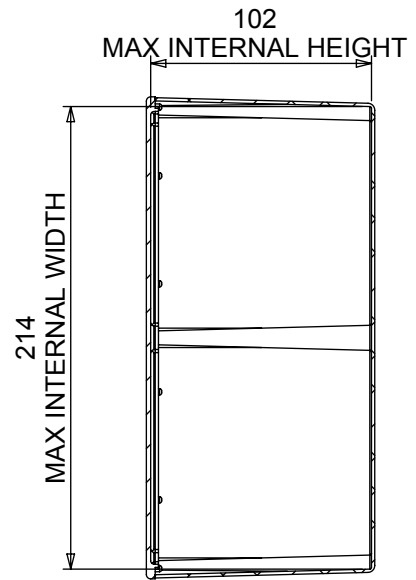
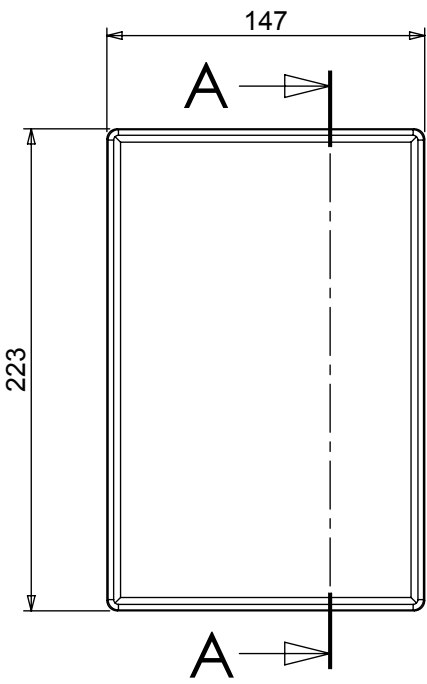
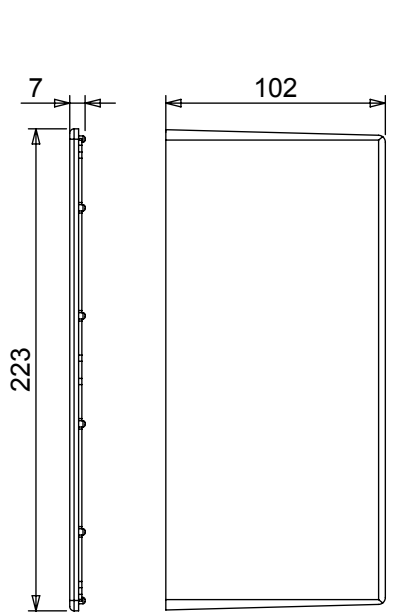

SECTION A-A

DELTRON Components
DELTRON Enclosures
ROXBURGH EMC

b'es **DEM**
Alpha3
 manufacturing

www.dem-uk.com

PROPRIETARY AND CONFIDENTIAL:
 THE INFORMATION CONTAINED IN THIS DRAWING IS THE SOLE PROPERTY OF ALPHA 3 MANUFACTURING. ANY REPRODUCTION IN PART OR AS A WHOLE WITHOUT THE WRITTEN PERMISSION OF ALPHA 3 MANUFACTURING IS PROHIBITED.

DEM Manufacturing is a division of Alpha 3 Manufacturing LTD
 DEM Manufacturing, Deltron Emcon House, Hargreaves Way,
 Sawcliffe Ind. Park, Scunthorpe, North Lincolnshire, DN15 8RF, UK

UNLESS OTHERWISE SPECIFIED DIMENSIONS ARE IN MILLIMETRES
 LINEAR & RADIAL TOLERANCE:
NO DECIMAL PLACES
1 DECIMAL PLACE
2 DECIMAL PLACES
ANGULAR TOLERANCE:

IF IN DOUBT ASK! DO NOT SCALE DRAWING!

FINISH: SEE NOTES
 MATERIAL: ALUMINIUM ALLOY

THE FINISHED PRODUCT SHOULD BE CLEAN AND FREE FROM ALL LIQUIDS AND DEBRIS. SURFACES SHOULD BE OF UNIFORM APPEARANCE FREE FROM SHARP EDGES, BURRS AND CORROSION

AUTHOR: Alex Yau
 EDITOR: DT
 APPROVER: DT

THIRD ANGLE PROJECTION

TITLE: PLAIN ENCLOSURE
 FILE: H ENCLOSURE
 PART: BOX & LID ASSEMBLY

SHEET 1 OF 1
 SCALE 1:3.5 A4

ISSUE/REV: 005
 VERSION: 22
 RELEASED
 EDIT DATE: 06 Jun 2017

Данный компонент на территории Российской Федерации

Вы можете приобрести в компании MosChip.

Для оперативного оформления запроса Вам необходимо перейти по данной ссылке:

<http://moschip.ru/get-element>

Вы можете разместить у нас заказ для любого Вашего проекта, будь то серийное производство или разработка единичного прибора.

В нашем ассортименте представлены ведущие мировые производители активных и пассивных электронных компонентов.

Нашей специализацией является поставка электронной компонентной базы двойного назначения, продукции таких производителей как XILINX, Intel (ex.ALTERA), Vicor, Microchip, Texas Instruments, Analog Devices, Mini-Circuits, Amphenol, Glenair.

Сотрудничество с глобальными дистрибьюторами электронных компонентов, предоставляет возможность заказывать и получать с международных складов практически любой перечень компонентов в оптимальные для Вас сроки.

На всех этапах разработки и производства наши партнеры могут получить квалифицированную поддержку опытных инженеров.

Система менеджмента качества компании отвечает требованиям в соответствии с ГОСТ Р ИСО 9001, ГОСТ РВ 0015-002 и ЭС РД 009

Офис по работе с юридическими лицами:

105318, г.Москва, ул.Щербаковская д.3, офис 1107, 1118, ДЦ «Щербаковский»

Телефон: +7 495 668-12-70 (многоканальный)

Факс: +7 495 668-12-70 (доб.304)

E-mail: info@moschip.ru

Skype отдела продаж:

moschip.ru

moschip.ru_4

moschip.ru_6

moschip.ru_9