



FEATURES

- 400W output power
- 12V main output
- 5V standby output of 15W
- 1U sized; dimensions 2.15"x13.67"x1.58"
- 8.6 Watts per cubic inch density
- Efficiency 83% at full load, 48Vdc and 50°C
- N+1 redundancy capable, including hot plugging (2 in parallel)
- Active current sharing on 12V main output, ORing FET
- Overvoltage, overcurrent, overtemperature protection
- Internal cooling fan (variable speed)
- PSMI and SMBus / I²C interface with bicolor LED status indicators
- RoHS compliant

PRODUCT OVERVIEW

The D1U2-D-400-12-HA4C is a 400 watt, DC input, isolated front end power supply with a 12V main output and a 5V (15W) standby. It features active current sharing for 2 supplies operated in parallel. The supply may be hot plugged, it recovers from overtemperature faults, and has status LEDs on the front panel in addition to logic and PSMI status signals. The supply comes in a low profile 1U package and has >8W/cubic inch power density, making it ideal for delivering reliable, efficient power to servers, workstations, storage systems and other 12V distributed power systems.

ORDERING GUIDE

Part Number	Power Output High Line AC	Power Output Low Line AC	Main Output	Standby Output	Airflow
D1U2-D-400-12-HA4C	400W	400W	12	5V	Back to front

INPUT CHARACTERISTICS

Parameter	Conditions	Min.	Nom.	Max.	Units
Voltage Operating Range		-40	-48	-72	Vdc
Turn-on Input Voltage	Ramp up	-43	-43.5	-44	
Turn-off Input Voltage	Ramp down	-38.5	-39	-39.5	A
Maximum current at Vin=-40Vdc	400W			15	
DC Inrush Current	Cold start between 0 to 200msec			30	Apk
Efficiency (-40Vdc to -72Vdc) including fan load	35% load	80			%
	50% load	80			
	100% load	83			

OUTPUT VOLTAGE CHARACTERISTICS

Output Voltage	Parameter	Conditions	Min.	Typ.	Max.	Units
12V	Voltage Set Point Accuracy			12.0		Vdc
	Line and Load Regulation		11.8		12.2	
	Ripple Voltage & Noise ¹	20MHz Bandwidth			120	mV p-p
	Output Current		0		33.3	A
	Load Capacitance		0		15,000	µF
5VSB	Voltage Set Point Accuracy			5.0		Vdc
	Line and Load Regulation		4.85		5.15	
	Ripple Voltage & Noise ¹	20MHz Bandwidth			50	mV p-p
	Output Current		0		3	A
	Load Capacitance		0		500	µF

¹ Ripple and noise are measured with 0.1 µF of ceramic capacitance and 10 µF of tantalum capacitance on each of the power supply outputs. A short coaxial cable with 50ohm scope termination is used.



OUTPUT CHARACTERISTICS					
Parameter	Conditions	Min.	Typ.	Max.	Units
Output Rise Monotonicity	No voltage excursion				
Start-up Time	DC ramp up		1.5	2.0	s
Transient Response	12V, 30-70% load step, 1A/μs di/dt			3	%
	5VSB, 30-70% load step, 0.1A/μs di/dt			3	
Current sharing accuracy (up to 2 in parallel)	At 100% load			±10	
Hot Swap Transients	All outputs within regulation				
Hold-up Time		8			ms

ENVIRONMENTAL CHARACTERISTICS					
Parameter	Conditions	Min.	Typ.	Max.	Units
Storage Temperature Range		-40		70	°C
Operating Temperature Range		0		50	
Operating Humidity	Noncondensing	10		90	%
Storage Humidity		5		95	
Altitude (without derating at 55°C)				3,000	m
Shock	30G non operating				
Sinusoidal Vibration	0.5G, 5 – 500 Hz				
MTBF	Calculated per Telcordia SR332M1C1 @25°C	300K			hrs
Safety Approvals	CSA/UL 60950-1-07-2nd Ed. IEC 60950-1:2005 (2nd Edition) EN 60950-1:2006 +A11 CE Marking per LV DIRECTIVE 2006/95/EC				
Input Fuse	Power Supply has internal 20A/125V fast blow fuses on both DC lines				
Material Flammability	UL 94V-0				
Switching Frequency	200KHz for Main Output Converter				
Weight	2.01lbs (0.912kg)				

PROTECTION CHARACTERISTICS						
Output Voltage	Parameter	Conditions	Min.	Typ.	Max.	Units
12V	Overtemperature (intake)	Autorestart	65	70	75	°C
	Overvoltage	Latching	14.0		14.5	V
	Overcurrent	Hiccup	115		130	%
5VSB	Overvoltage	Latching	5.7		5.9	V
	Overcurrent	Autorecovery	4.4		6.0	A

ISOLATION CHARACTERISTICS					
Parameter	Conditions	Min.	Typ.	Max.	Units
Insulation Safety Rating / Test Voltage	Input to Output - Reinforced	3000			Vrms
	Input to Chassis - Basic	1500			Vrms
Isolation	Output to Chassis	500			Vrms
Material Flammability	UL 94V-0				

CONTROL SIGNALS	
Condition	LED Status
Standby - ON; Main output - OFF; DC PRESENT	Blinking green
Standby - ON; Main output - ON	Solid green
Main/standby output overcurrent, undervoltage, overvoltage warning	Blinking yellow
FAN_FAULT; overtemperature; stand-by overcurrent, undervoltage	Yellow

EMISSIONS AND IMMUNITY		
Characteristic	Standard	Compliance
Conducted Emissions	FCC 47 CFR Part 15/CISPR 22/EN55022	Class B
ESD Immunity	IEC/EN 61000-4-2	Level 3 criteria A
Radiated Field Immunity	IEC/EN 61000-4-3	Level 3 criteria B
Electrical Fast Transients/Burst Immunity	IEC/EN 61000-4-4	Level 3 criteria B
Surge Immunity	IEC/EN 61000-4-5	Level 2 criteria A
Radiate Field Conducted Immunity	IEC/EN 61000-4-6	Level 3 criteria A
Magnetic Field Immunity	IEC/EN 61000-4-8	3 A/m criteria B

DC OUTPUT CONNECTOR AND SIGNALS

The DC Output Connector is a TYCO MINIPAK HDL Connector **TYCO P/N: 1926734-1**. Mating pin sequencing shall be 12V_RTN first, 12V second, signals third and PSKILL_L signal last. PSKILL_L is the last to mate and first to break and is used as a power supply output enable for the 12V rail.

Mating Part: Tyco PN 1-1926733-8

Power Supply Output Connector Isometric and Front Views

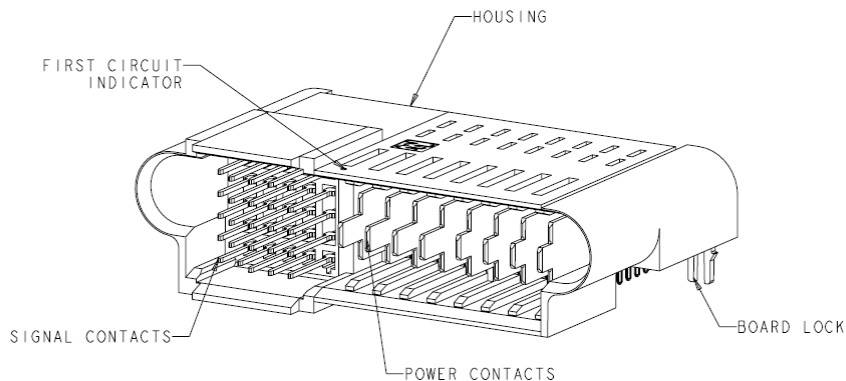

Front Connector View Looking at Blades and Pins (view looking in at rear of power supply)

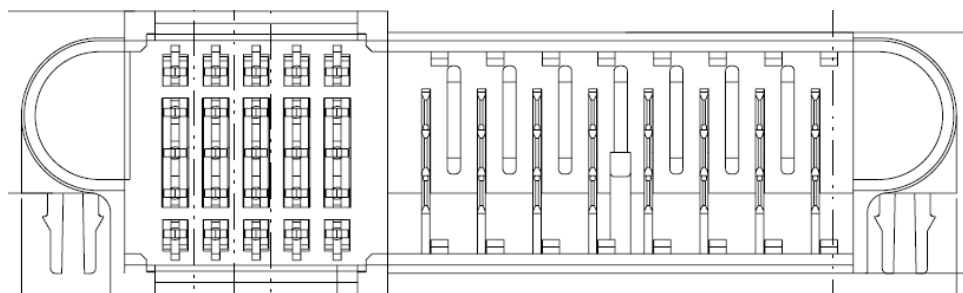

DC OUTPUT CONNECTOR AND SIGNALS (continued)

View into mating face of 25S8P MINIPAK HDL Plug

Column:	1	2	3	4	5	1	2	3	4	5	6	7	8
Row:	1	2	3	4	5	6	7	8	9	10	11	12	13
e													
d													
c													
b													
a													

Signal contacts: choice of Level 1 (L1) or Level 2 (L2)

Power contacts: choice of Level 2 (L2) or Level 3 (L3)

POWER SUPPLY OUTPUT CONNECTOR POWER BLADE AND SIGNAL PIN ALLOCATION

Power Blade Number	Signal	Function	Signal Direction	Blade Sequencing
P1, P2, P3, P4	RTN	12V Return	Output	Level 3 UPM PWR
P5, P6, P7, P8	12V	12V Output	Output	Level 2 UPM PWR
A1	SMB_ALERT_L	I2C Serial Bus Interrupt	Output	Level 2 Signal
A2	PSON_L	Power Supply ON	Input	
A3	PSKILL_L	Power Supply Enable	Input	Level 1 Signal
A4, A5	5VSB	5V Standby Voltage	Output	Level 2 Signal
B1	SMB_SCL	I2C Serial Bus Clock	Bi-directional	Level 2 Signal
B2, B3	RTN	Ground	Output	
B4, B5	5VSB	5V Standby Voltage		
C1	SMB_SDA	I2C Serial Bus Data / Address	Bi-directional	Level 2 Signal
C2, C3, C4, C5	RTN	Ground	Output	Level 2 Signal
D1	SMB_A1	I2C Serial Bus Address Bit A1	Input	
D2	RTN	Ground	Output	
D3	12LS	12V Current Share Line	Bi-directional	
D4	12V_RS-	12V Remote Sense Negative	Input	
D5	12V_RS+	12V Remote Sense Positive		
E1	SMB_A0	I2C Serial Bus Address Bit A0	Input	Level 2 Signal
E2	RTN	Ground	Output	
E3	PWOK_H	Power OK Status Bit		
E4	FF1_H	Fan Fail #1 Status Output		
E5	RTN	Ground		

WIRING DIAGRAM

----- Dotted lines show optional remote sense connections.
Optional remote sense lines can be attached to a load that is a distance away from the power supply to improve regulation at the load.

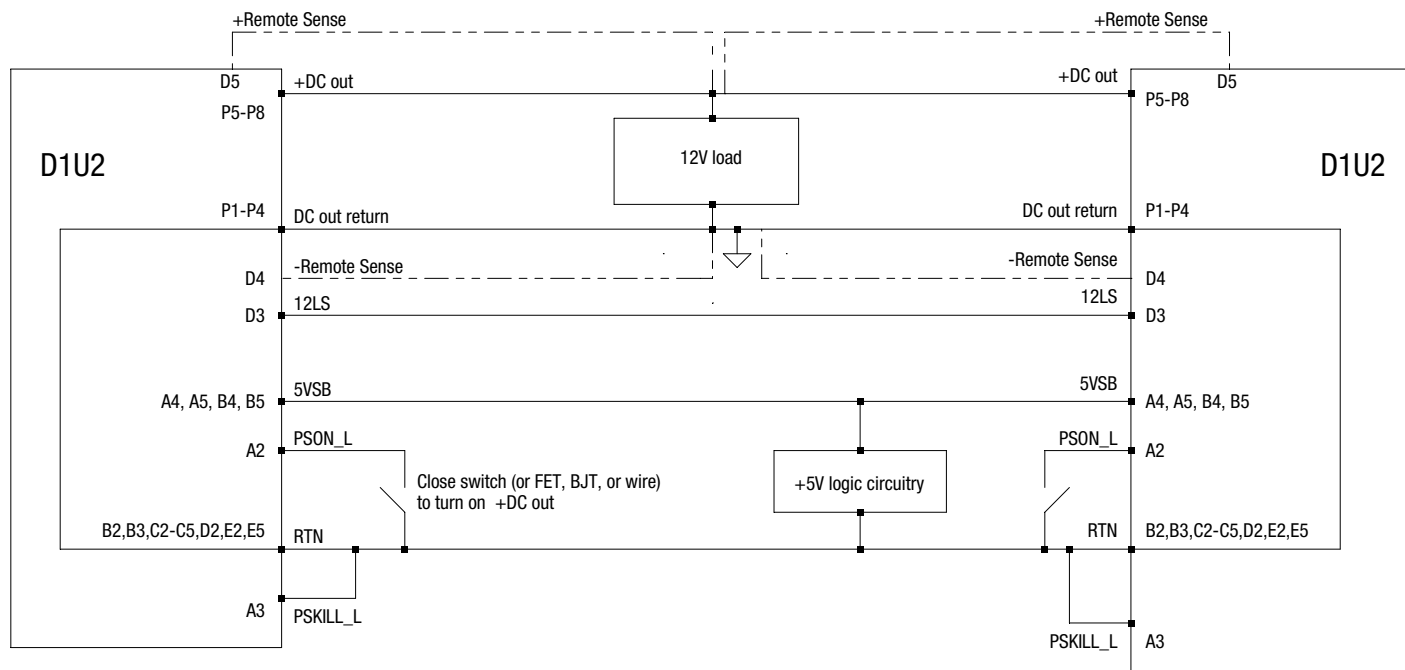

CURRENT SHARING NOTES

12V Output: Current sharing is achieved using the active current share method. (See wiring diagram section for connection details.) The total combined load must be below 400W at startup. Startup of parallel power supplies is not internally synchronized. It is recommended that the paralleled power supplies be turned on at the same time (with their PSON_L signals). Current sharing can be achieved with or without remote sense connected to the common load.

5VSB Output: 5VSB outputs can be tied together for redundancy but total combined output power must not exceed 15W. The 5VSB output has internal ORing MOSFET for additional redundancy / internal short protection.

Up to 2 units can be paralleled together. Outputs of AC input units (D1U2-W-400) and DC input units (D1U2-D-400) can be paralleled together. Please consult your Murata sales representative if operation with more than two units in parallel is needed.

MECHANICAL DIMENSIONS

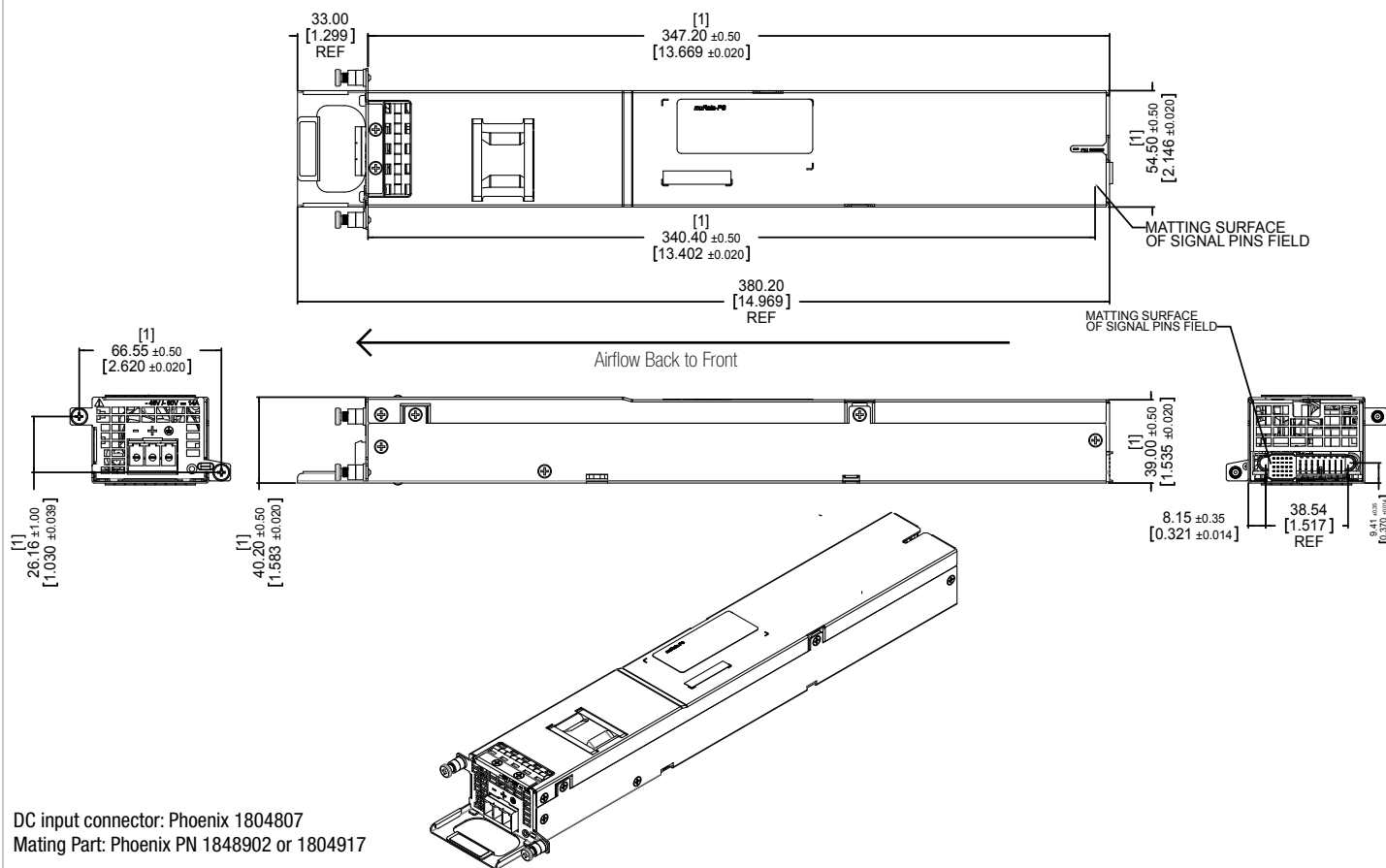

Dimensions: 2.15" x 13.67" x 1.58" [54.5mm x 347.2mm x 40.2mm]

OPTIONAL ACCESSORIES

Description	Part Number
12V D1U2 Output Connector Card	D1U2-12-CONC

APPLICATION NOTES

Document Number	Description
TBD	Output Connector Card for D1U2
TBD	D1U2 Communication Protocol

Murata Power Solutions, Inc.
11 Cabot Boulevard, Mansfield, MA 02048-1151 U.S.A.
ISO 9001 and 14001 REGISTERED



This product is subject to the following **operating requirements** and the **Life and Safety Critical Application Sales Policy**:
Refer to: <http://www.murata-ps.com/requirements/>

Murata Power Solutions, Inc. makes no representation that the use of its products in the circuits described herein, or the use of other technical information contained herein, will not infringe upon existing or future patent rights. The descriptions contained herein do not imply the granting of licenses to make, use, or sell equipment constructed in accordance therewith. Specifications are subject to change without notice.
© 2012 Murata Power Solutions, Inc.

Данный компонент на территории Российской Федерации

Вы можете приобрести в компании MosChip.

Для оперативного оформления запроса Вам необходимо перейти по данной ссылке:

<http://moschip.ru/get-element>

Вы можете разместить у нас заказ для любого Вашего проекта, будь то серийное производство или разработка единичного прибора.

В нашем ассортименте представлены ведущие мировые производители активных и пассивных электронных компонентов.

Нашей специализацией является поставка электронной компонентной базы двойного назначения, продукции таких производителей как XILINX, Intel (ex.ALTERA), Vicor, Microchip, Texas Instruments, Analog Devices, Mini-Circuits, Amphenol, Glenair.

Сотрудничество с глобальными дистрибьюторами электронных компонентов, предоставляет возможность заказывать и получать с международных складов практически любой перечень компонентов в оптимальные для Вас сроки.

На всех этапах разработки и производства наши партнеры могут получить квалифицированную поддержку опытных инженеров.

Система менеджмента качества компании отвечает требованиям в соответствии с ГОСТ Р ИСО 9001, ГОСТ РВ 0015-002 и ЭС РД 009

Офис по работе с юридическими лицами:

105318, г.Москва, ул.Щербаковская д.3, офис 1107, 1118, ДЦ «Щербаковский»

Телефон: +7 495 668-12-70 (многоканальный)

Факс: +7 495 668-12-70 (доб.304)

E-mail: info@moschip.ru

Skype отдела продаж:

moschip.ru

moschip.ru_4

moschip.ru_6

moschip.ru_9