

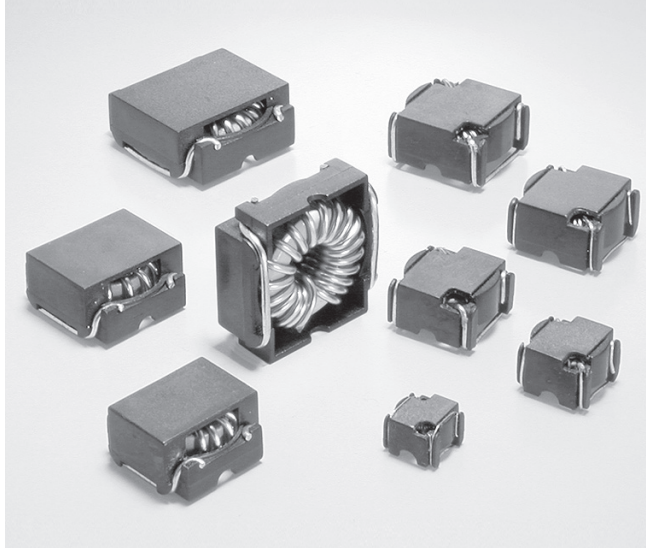

Toroid Power Inductors – SPT Series



- Toroid winding eliminates stray electromagnetic emissions
- Two versions: Standard, current ratings up to 8 Amps; High current, with ratings up to 12.2 Amp

Core material Powered iron

Core and winding loss See www.coilcraft.com/coreloss

Terminations RoHS compliant tin-silver over copper. Other terminations available at additional cost.

Ambient temperature –40°C to +85°C

Maximum part temperature: The part temperature should not exceed +85°C (ambient + self-heating). Prolonged operation above +85°C may result in a permanent increase in core loss and part failure due to thermal aging of the core material.

Storage temperature Component: –40°C to +85°C.
Packaging: –40°C to +80°C

Resistance to soldering heat Max three 40 second reflows at +260°C, parts cooled to room temperature between cycles

Moisture Sensitivity Level (MSL) 1 (unlimited floor life at <30°C / 85% relative humidity)

Failures in Time (FIT) / Mean Time Between Failures (MTBF)
38 per billion hours / 26,315,789 hours, calculated per Telcordia SR-332

PCB washing Only pure water or alcohol recommended

Part number ¹	L ² ±20% (µH)	DCR max (mOhm)	SRF typ ³ (MHz)	Isat (A) ⁴			Body size
				10% drop	20% drop	30% drop	
Standard series							
SPT20L-112ML_	1.1	16.0	130	3.2	4.8	6.7	1
SPT38L-382ML_	3.8	9.3	61	4.0	6.1	8.2	3
SPT30L-522ML_	5.2	24.2	47	2.8	4.2	5.8	2
SPT20L-702ML_	7.0	95.0	37	1.2	1.8	2.5	1
SPT38L-752ML_	7.5	22.8	50	2.7	4.2	5.8	3
SPT44L-792ML_	7.9	16.2	26	3.5	5.4	7.3	4
SPT30L-123ML_	12	54.7	23.9	1.9	2.8	3.7	2
SPT44L-143ML_	14	23.6	15.6	2.8	4.1	5.7	4
SPT50L-163ML_	16	19.7	14.3	2.8	4.2	5.8	5
SPT38L-223ML_	22	63	18.1	1.5	2.3	3.1	3
SPT20L-233ML_	23	320	13.5	0.6	1.0	1.3	1
SPT50L-263ML_	26	32	11.2	2.3	3.4	4.6	5
SPT30L-353ML_	35	166	11.0	1.1	1.6	2.2	2
SPT44L-413ML_	41	85	8.30	1.6	2.3	3.1	4
SPT38L-733ML_	73	290	10.8	0.81	1.3	1.7	3
SPT50L-733ML_	73	133	4.56	1.4	2.0	2.7	5
SPT30L-174ML_	170	640	3.84	0.44	0.68	0.95	2
SPT38L-294ML_	290	657	2.87	0.41	0.64	0.90	3
SPT50L-564ML_	560	550	1.54	0.37	0.59	0.81	5
SPT38L-674ML_	670	1200	1.38	0.26	0.40	0.55	3
SPT44L-115ML_	1100	1908	1.35	0.25	0.41	0.57	4
SPT50L-205ML_	2000	1932	1.35	0.18	0.29	0.41	5
High current series							
SPT44H-282ML_	2.8	4.6	74	5.8	8.8	12.2	6
SPT44H-422ML_	4.2	6.6	61	5.0	7.8	10.9	6
SPT50H-652ML_	6.5	7.2	27.3	4.6	6.7	9.1	7
SPT50H-842ML_	8.4	8.5	22.8	4.3	6.4	8.5	7
SPT68H-113ML_	11	8.2	25.9	4.8	7.2	9.9	8
SPT68H-183ML_	18	12.5	12.0	3.9	5.7	7.7	8

1. When ordering, specify **termination** and **packaging** codes:

SPT20L-112MLD

Termination: L = RoHS compliant tin-silver over copper.

Special order:

T = RoHS tin-silver-copper (95.5/4/0.5) or
S = non-RoHS tin-lead (63/37).

Packaging: D = 13" machine-ready reel

EIA-481 embossed plastic tape.

Body size 1: 750 per full reel.

Body sizes 2–3: 350 per full reel.

Body size 4: 300 per full reel.

Body sizes 5–6: 250 per full reel.

Body sizes 7–8: 200 per full reel.

B = Less than full reel

In tape, but not machine ready. To have a leader and trailer added (\$25 charge), use code letter D instead.

2. Inductance tested at 100 kHz, 0.1 Vrms on Agilent/HP 4192A.
3. SRF measured on Agilent/HP 8753ES network analyzer.
4. DC current that causes the specified inductance drop from its value without current.
5. Electrical specifications at 25°C.
Refer to Doc 362 "Soldering Surface Mount Components" before soldering.



www.coilcraft.com

US +1-847-639-6400 sales@coilcraft.com

UK +44-1236-730595 sales@coilcraft-europe.com

Taiwan +886-2-2264 3646 sales@coilcraft.com.tw

China +86-21-6218 8074 sales@coilcraft.com.cn

Singapore +65-6484 8412 sales@coilcraft.com.sg

Document 280-1 Revised 12/09/10

© Coilcraft Inc. 2011

This product may not be used in medical or high risk applications without prior Coilcraft approval. Specifications subject to change without notice. Please check our web site for latest information.



Toroid Power Inductors – SPT Series

Body size 1 - 5

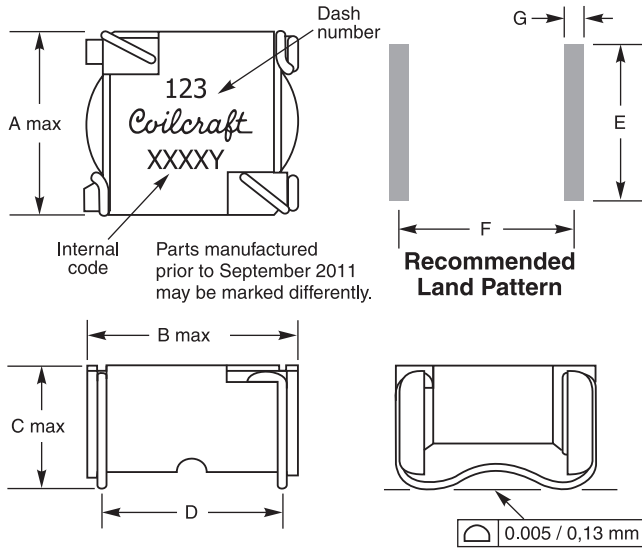

Body size 6 - 8

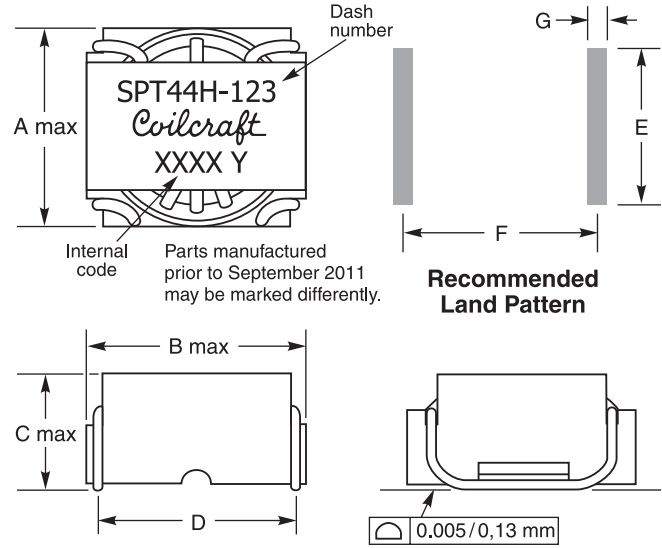

Size	A max	B max	C max	D ¹	E ²	F ²	G	Weight (g)
1	0.34/8,64	0.34/8,64	0.28/7,00	0.26/6,60	0.30/7,62	0.27/6,86	0.06/1,52	0.47-0.54
2	0.44/11,05	0.44/11,18	0.37/9,50	0.35/8,89	0.40/10,16	0.36/9,14	0.06/1,52	1.42-1.59
3	0.56/14,22	0.56/14,35	0.37/9,50	0.45/11,43	0.52/13,21	0.46/11,68	0.06/1,52	2.73-3.34
4	0.59/14,99	0.61/15,62	0.41/10,50	0.50/12,70	0.55/13,97	0.51/12,95	0.06/1,52	3.57-4.08
5	0.67/17,02	0.70/17,78	0.41/10,50	0.58/14,73	0.62/15,75	0.59/14,99	0.06/1,52	5.19-5.97
6	0.66/16,89	0.66/16,89	0.41/10,50	0.56/14,22	0.49/12,45	0.57/14,48	0.08/2,03	4.23-4.48
7	0.74/18,80	0.74/18,80	0.41/10,50	0.63/16,00	0.56/14,22	0.64/16,26	0.08/2,03	6.18-6.53
8	0.94/23,88	0.94/23,88	0.41/10,50	0.82/20,83	0.70/17,78	0.83/21,08	0.08/2,03	11.12-11.63

Dimensions are in inches/mm. Unless specified, tolerance is ± 0.009/0,25.
 1. ±0.015/0,38
 2. ±0.005/0,13

Typical L vs Current (Standard series)

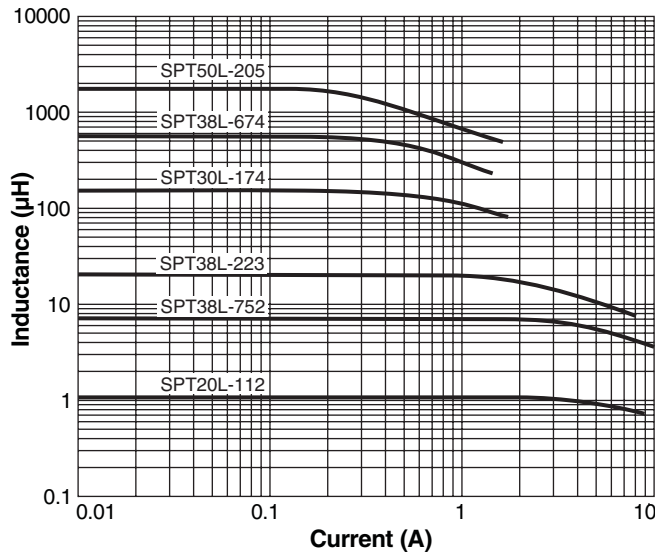

Typical L vs Current (High current series)

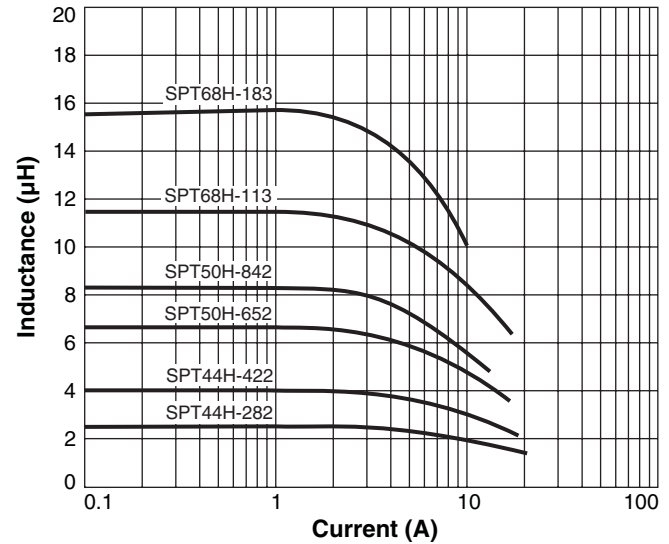

US +1-847-639-6400 sales@coilcraft.com
 UK +44-1236-730595 sales@coilcraft-europe.com
 Taiwan +886-2-2264 3646 sales@coilcraft.com.tw
 China +86-21-6218 8074 sales@coilcraft.com.cn
 Singapore +65-6484 8412 sales@coilcraft.com.sg

Document 280-2 Revised 12/09/10
 © Coilcraft Inc. 2011
 This product may not be used in medical or high risk applications without prior Coilcraft approval. Specifications subject to change without notice. Please check our web site for latest information.



Toroid Power Inductors – SPT Series

Typical Temperature Rise vs Current*

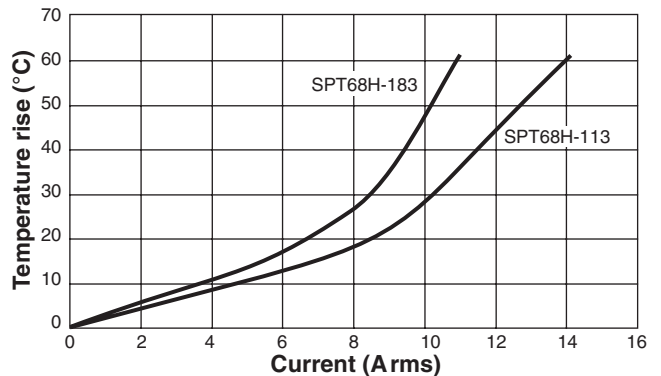
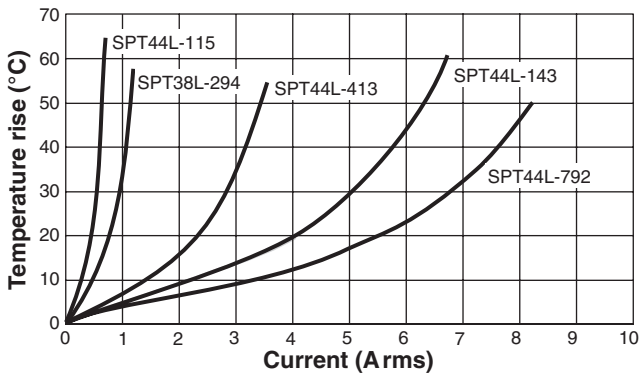
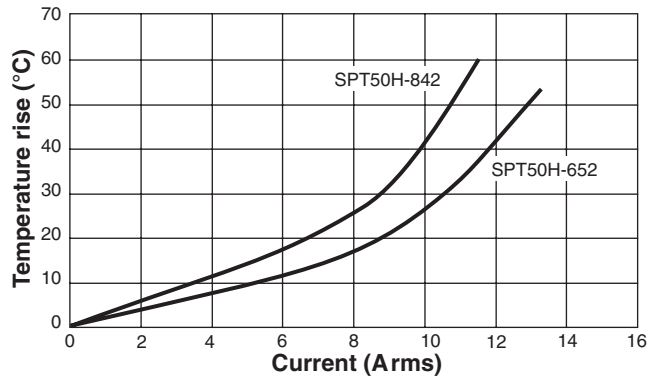
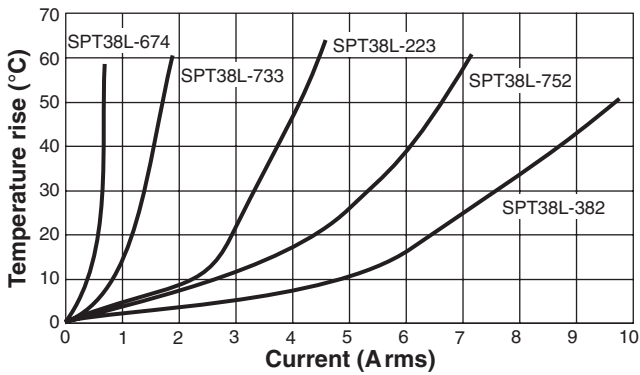
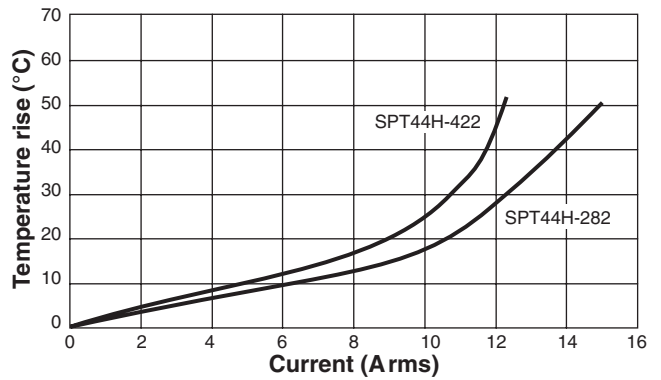
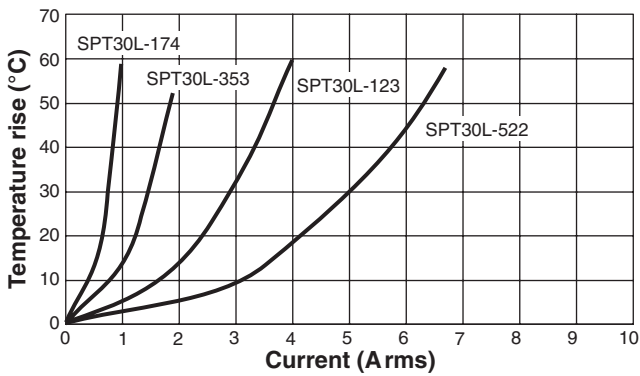
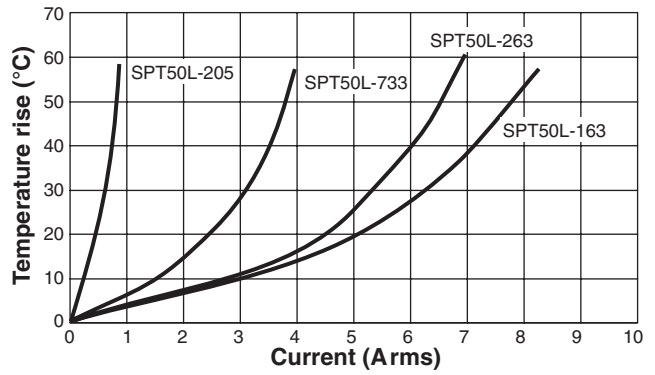
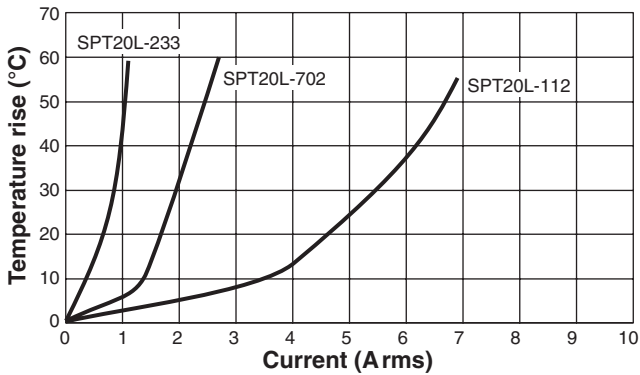

* Measured at 25°C ambient.

Данный компонент на территории Российской Федерации

Вы можете приобрести в компании MosChip.

Для оперативного оформления запроса Вам необходимо перейти по данной ссылке:

<http://moschip.ru/get-element>

Вы можете разместить у нас заказ для любого Вашего проекта, будь то серийное производство или разработка единичного прибора.

В нашем ассортименте представлены ведущие мировые производители активных и пассивных электронных компонентов.

Нашей специализацией является поставка электронной компонентной базы двойного назначения, продукции таких производителей как XILINX, Intel (ex.ALTERA), Vicor, Microchip, Texas Instruments, Analog Devices, Mini-Circuits, Amphenol, Glenair.

Сотрудничество с глобальными дистрибьюторами электронных компонентов, предоставляет возможность заказывать и получать с международных складов практически любой перечень компонентов в оптимальные для Вас сроки.

На всех этапах разработки и производства наши партнеры могут получить квалифицированную поддержку опытных инженеров.

Система менеджмента качества компании отвечает требованиям в соответствии с ГОСТ Р ИСО 9001, ГОСТ РВ 0015-002 и ЭС РД 009

Офис по работе с юридическими лицами:

105318, г.Москва, ул.Щербаковская д.3, офис 1107, 1118, ДЦ «Щербаковский»

Телефон: +7 495 668-12-70 (многоканальный)

Факс: +7 495 668-12-70 (доб.304)

E-mail: info@moschip.ru

Skype отдела продаж:

moschip.ru

moschip.ru_4

moschip.ru_6

moschip.ru_9