

**Power Relay T9A**

- 1 pole 30 A, 1 NO or 1 CO contact
- High breaking capacity 7200 VA
- PCB- and PCB/quick connect terminals
- Chassis mount version with quick connect terminals
- UL-class F as standard
- Ambient temperature 85°C

**Applications**

**HVAC, power supplies, domestic appliances, measurement & control**

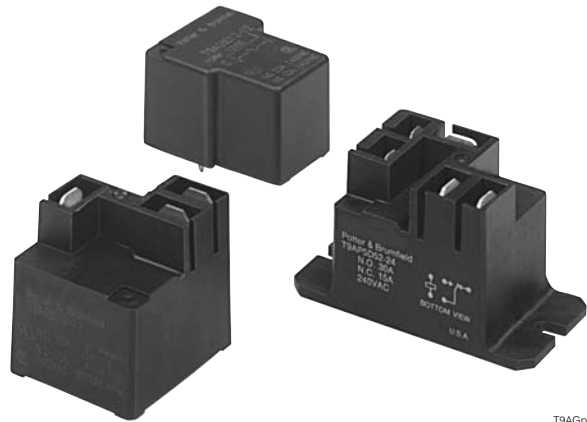

T9AGp

**Approvals**



Technical data of approved types on request

**Contact data**

Contact configuration	1 NO contact	1 CO contact
Contact set	single contact	
Type of interruption	micro disconnection	
Rated voltage / max. switching voltage AC	240 / 277 VAC	
Rated current NO / NC contact	30 A	20 / 10 A
Contact material	AgCdO, AgSnOInO	
Minimum contact load	≥ 1A, 5VDC / 12 VAC	
Operate- / release time including bounce time	max. 15 / 15ms	

**Contact ratings**

Type	Contact	Load	Ambient temp. [°C]	Cycles
<b>UL 508</b>				
T9A AgCdO	NO	30 A, 240 VAC, general purpose	85°C	100x10 <sup>3</sup>
T9A AgCdO	NO	15 A 240 VAC, resistive	105°C	100x10 <sup>3</sup>
T9A AgCdO	CO	30 A / 20 A 240 VAC, resistive	25°C	6x10 <sup>3</sup>
T9A AgCdO	CO	20 A / 10 A 28 VDC, resistive	25°C	100x10 <sup>3</sup>
T9A AgSnOInO	NO	30 A, 240 VAC, general purpose	25°C	100x10 <sup>3</sup>

**Coil data**

Rated coil voltage range DC coil	5...48 VDC
For AC coil version please refer to T9C datasheet	

**Coil versions, DC-coil**

Coil code	Rated voltage VDC	Operate voltage VDC	Release voltage VDC	Coil resistance Ω	Rated coil power mW
6	6	4.5	0.6	36±10%	1000
12	12	9.0	1.2	144±10%	1000
24	24	18.0	2.4	576±10%	1000
48	48	36.0	4.8	2304±10%	1000

All figures are given for coil without preenergization, at ambient temperature +23°C  
Other coil voltages on request

**Insulation**

Insulation resistance coil-contact circuit	> 10 <sup>9</sup> Ohms
Dielectric strength coil-contact circuit	2500 V <sub>rms</sub>
open contact circuit	1500 V <sub>rms</sub>
Clearance / creepage coil-contact circuit	≥ 2.5 / 4 mm; ≥ 3.1 / 6.3 mm (UL508)

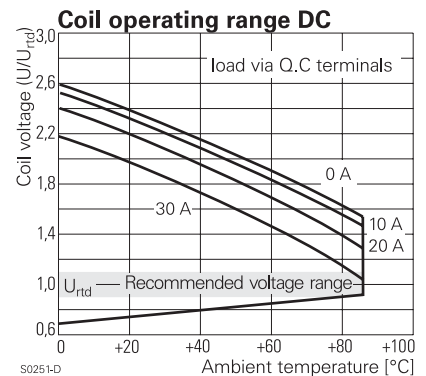
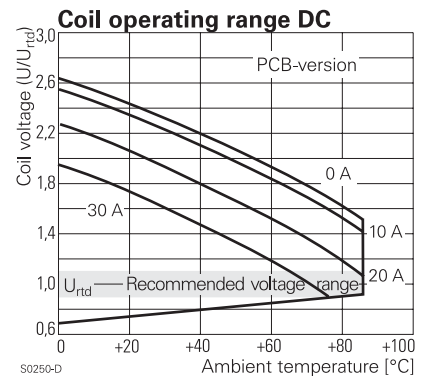

**Power Relay T9A (Continued)**

**Other data**

Mechanical endurance	typ. $10 \times 10^6$ cycles
Material	RoHS - Directive 2002/95/EC compliant per product date code 0509
Environment	RT III - wash tight ('Enclosure S') RT I - dust protected ('Enclosure P')
Processing	Relay weight 26 / 33 g Packaging unit 250 pcs

**PCB layout / terminal assignment**

Bottom view on solder pins

PCB version

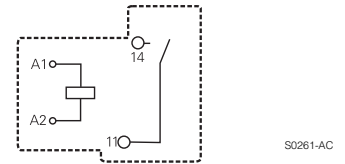
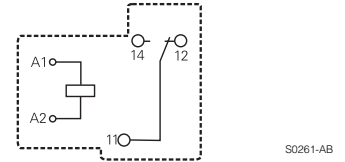
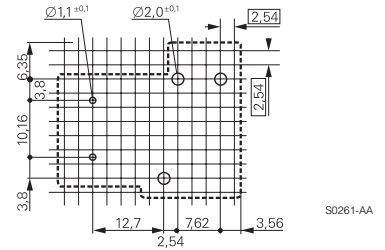

**Dimensions**

PCB version

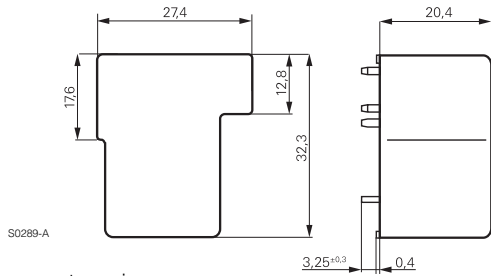

PCB-/quick connect version

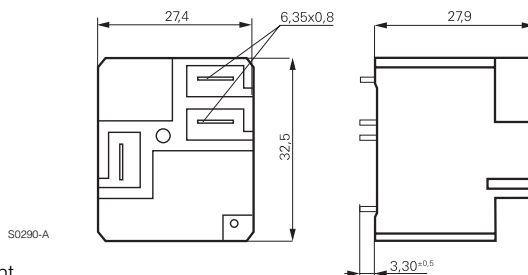

Flange mount

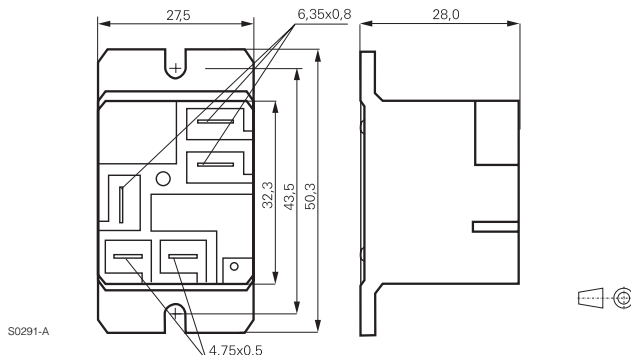

PCB-/quick connect version

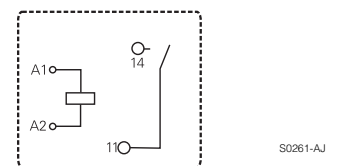
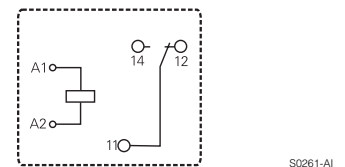
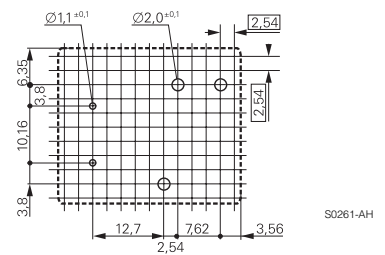

**Power Relay T9A** (Continued)

<b>Product key</b>	Typical product key		<b>T9A</b>	<b>S</b>	<b>1</b>	<b>D</b>	<b>2</b>	<b>2</b>	<b>-24</b>
<b>Type</b>	<b>T9A</b> Power relay T9A								
<b>Enclosure</b>	<b>P</b> dust protected (flange mount) <b>S</b> wash tight (PCB- or PCB-/quick connect version)								
<b>Contact configuration</b>	<b>1</b> 1 NO contact (1 form A) <b>5</b> 1 CO contact (1 form C)								
<b>Coil version</b>	<b>D</b> DC coil 1 W								
<b>Mounting</b>	<b>1</b> PCB-version <b>2</b> PCB-terminals for coil and contacts, quick connect terminals for contacts <b>5</b> Flange mount, 4.75 mm quick connect term. for coil, 6.35 mm quick connect term. for contacts								
<b>Contact material</b>	<b>2</b> AgCdO <b>4</b> AgSnOInO								
<b>Coil</b>	Coil code: please refer to coil versions table								

Other types on request

Product key	Enclosure	Mounting	Cont. material	Cont.configuration	Coil	Part number
T9AS1D12-9	wash tight	pcb terminals	AgCdO	1 NO contact	9 VDC	2-1393210-2
T9AS1D12-12					12 VDC	1-1393210-3
T9AS1D12-24					24 VDC	1-1393210-8
T9AS1D12-48					48 VDC	1-1393210-9
T9AS1D22-12		pcb + quick conn.			12 VDC	1-1419104-7
T9AS5D12-24		pcb terminals		1 CO contact	24 VDC	3-1393210-7
T9AS5D22-12		pcb + quick conn.			12 VDC	3-1419104-3
T9AS5D22-24					24 VDC	3-1419104-6

## Данный компонент на территории Российской Федерации

### Вы можете приобрести в компании MosChip.

Для оперативного оформления запроса Вам необходимо перейти по данной ссылке:

<http://moschip.ru/get-element>

Вы можете разместить у нас заказ для любого Вашего проекта, будь то серийное производство или разработка единичного прибора.

В нашем ассортименте представлены ведущие мировые производители активных и пассивных электронных компонентов.

Нашей специализацией является поставка электронной компонентной базы двойного назначения, продукции таких производителей как XILINX, Intel (ex.ALTERA), Vicor, Microchip, Texas Instruments, Analog Devices, Mini-Circuits, Amphenol, Glenair.

Сотрудничество с глобальными дистрибьюторами электронных компонентов, предоставляет возможность заказывать и получать с международных складов практически любой перечень компонентов в оптимальные для Вас сроки.

На всех этапах разработки и производства наши партнеры могут получить квалифицированную поддержку опытных инженеров.

Система менеджмента качества компании отвечает требованиям в соответствии с ГОСТ Р ИСО 9001, ГОСТ РВ 0015-002 и ЭС РД 009

### Офис по работе с юридическими лицами:

105318, г.Москва, ул.Щербаковская д.3, офис 1107, 1118, ДЦ «Щербаковский»

Телефон: +7 495 668-12-70 (многоканальный)

Факс: +7 495 668-12-70 (доб.304)

E-mail: [info@moschip.ru](mailto:info@moschip.ru)

Skype отдела продаж:

moschip.ru

moschip.ru\_4

moschip.ru\_6

moschip.ru\_9